



**Visualline**  
The power of communication



Calidad, confianza, responsabilidad  
Quality, trust, responsibility  
Qualität, Vertrauen, Verantwortung  
Qualité, confiance, responsabilité



Todo el equipo de **Rocada** le da las gracias por su confianza en nuestros productos.  
All **Rocada** Team would like to thank you for your confidence in our products.  
Das gesamte **Rocada**-Team möchte sich bei Ihnen für Ihr Vertrauen in unsere Produkte bedanken.  
Toute l'équipe **Rocada** vous remercie pour votre confiance en ses produits

Marc Roca  
CEO

[ESP] Los productos presentados en este catálogo son reproducciones fotográficas impresas, por lo cual pueden ocasionarse leves variaciones de color en el resultado final. Así pues, este catálogo, aún asemejándose mucho a la realidad, sirve sólo a título orientativo.

Rocada se reserva el derecho de modificar sin previo aviso características, medidas y colores de nuestros productos.

[ENG] The products presented in this catalogue are printed photographic reproductions, so there can be colour variations in the end result. Although its contents bear a close resemblance to the actual products, the catalogue is therefore for guidance purposes only.

Rocada reserves the right to change product specifications, sizes or colors without prior notice.

[DE] Bei den in diesem Katalog abgebildeten Produkten handelt es sich um fotografische Wiedergaben, weshalb es hinsichtlich der Farben zu leichten Abweichungen vom Original kommen kann. Trotz weitestgehender Übereinstimmung mit dem Endprodukt ist dieser Katalog also rein informativ zu verstehen.

Rocada behält sich das Recht vor, Merkmale, Abmessungen und Farben der vorgestellten Produkte ohne Vorankündigung zu verändern.

[FR] Les produits présentés dans ce catalogue sont des reproductions photographiques imprimées ; de ce fait, il peut y avoir de légères variations de couleur dans le produit final. Ce catalogue, bien que très proche de la réalité, ne peut donc servir qu'à titre de référence.

Rocada se réserve le droit de modifier sans avis préalable les caractéristiques, les mesures et les couleurs de ses produits.

## Stock permanente • Permanent stock Permanente Lagerhaltung • Stock permanent

### [ESP] Rapidez • Eficacia • Stock permanente • Entrega inmediata

En un nuevo mundo globalizado, no puedes permitirte el lujo de malgastar espacio y tiempo, Rocada lo sabe. Una estructura de 20.000m<sup>2</sup> y un almacén de 5.000m<sup>2</sup> nos permiten disponer de un stock permanente de productos que asegura una entrega inmediata de 7 días.

### [ENG] Speed • Efficiency • Permanent stock • Immediate delivery

In a new globalized world, one cannot permit himself the luxury of wasting space and time. Rocada knows this. A structure of 20,000 m<sup>2</sup> and a warehouse of 5,000 m<sup>2</sup> allows us to have the product available for immediate 7-day delivery.

### [DE] Schnelligkeit • Wirksamkeit • Permanente Lagerung • Sofortige Lieferung

In einer neuen globalisierten Welt kann man sich den Luxus einer Platz- und Zeitverschwendung nicht erlauben. Rocada ist sich dessen bewusst. Ein Betriebsfläche mit 20.000m<sup>2</sup> und ein Warenlager von 5.000m<sup>2</sup> erlaubt es uns, über die Produkte zu verfügen und eine sofortige, 7-tägige Lieferung zu garantieren.

### [FR] Rapidité • Efficacité • Stock permanent • Livraison immédiate

À l'heure de la mondialisation, vous ne pouvez plus vous permettre le luxe de mal gérer votre espace et votre temps. Rocada en est conscient. Une structure de 20000 m<sup>2</sup> et un entrepôt de 5000 m<sup>2</sup> nous permettent de disposer d'un stock permanent de produits afin de garantir une livraison rapide départ usine dans les 7 jours.



## Servicio de montaje Montageservice

[ESP] Ofrecemos la posibilidad de montar cualquier material en cualquier punto del territorio español por un módico precio sin pedido mínimo.

[DE] Wir bieten Ihnen die Möglichkeit, unseren Montageservice in jedem Ort in Deutschland zu einem kleinen Aufpreis in Anspruch zu nehmen, unabhängig von der Höhe des Bestellwerts. Bitte erfragen Sie bei uns vorab die Höhe des Aufpreises.

## Proyectos a medida Custom projects Benutzerdefinierte Projekte Projets personnalisés

[ESP] Ofrecemos la posibilidad de realizar proyectos a medida con material estándares de nuestro catálogo o con maderas y acabados especiales. Para más información consultar a Rocada.





**[ESP]** La certificación alemana GS reconocida a nivel mundial como una de las mejores a nivel europeo, garantiza la seguridad, calidad y continuidad de la fabricación del producto, dando al usuario una máxima seguridad y tranquilidad en su compra.

**[ENG]** GS German certification is world recognised as one of the best in Europe, a guarantee of safety, quality and product production continuity giving the user maximum security and peace of mind when purchasing.

**[DE]** Die deutsche GS-Zertifizierung ist weltweit als eine der besten europäischen Zertifizierungen anerkannt. Das GS-Zeichen steht für geprüfte Sicherheit, Qualität und Kontinuität der Warenproduktion und signalisiert dem Endverbraucher ein hohes Maß an Sicherheit.

**[FR]** La certification allemande GS est reconnue au niveau mondial comme une des meilleures en Europe. Elle garantit la sécurité, la qualité et le suivi de production du produit, elle assure au consommateur une sécurité maximale et la tranquillité par rapport à son achat.



## ISO 9001:2015

**[ESP]** La calidad y fiabilidad de nuestros procesos de producción están avalados por la certificación ISO 9001:2015

**[ENG]** The quality and reliability of our production processes are guaranteed by ISO 9001:2015 certification.

**[DE]** Die Qualität und Zuverlässigkeit unserer Produktionsprozesse ist durch ISO 9001:2015

**[FR]** La qualité et la fiabilité de nos processus de production sont garanties par la certification ISO 9001:2015



## ISO 14001:2015

**[ESP]** Respetar y proteger el medioambiente es prioritario en nuestros procesos productivos. El uso de productos reciclados y la utilización razonable de los recursos son prioridades

**[ENG]** Respect for and protection of the environment are priorities in our production processes. The use of recycled products and the reasonable use of resources are unbending priorities.

**[DE]** Der Umweltschutz gehört im Rahmen unserer Produktionsprozesse zu den zentralen Anliegen. Der Einsatz von Recyclingmaterialien und die vernünftige Nutzung von natürlichen Ressourcen steht für uns an erster Stelle.

**[FR]** Respecter et protéger l'environnement est une priorité pour nos processus de production. L'utilisation de matières recyclées et l'utilisation raisonnable des ressources sont des priorités essentielles.



# SkinWhiteBoard

*unlimited whiteboard*



Skinwhiteboard, unlimited whiteboard





## ¿Qué es?

What is it? / SkinWHITEBOARD, Das rahmenlose Endloswhiteboard-System  
Qu'est ce que c'est?

**[ESP]** El SkinWHITEBOARD es un panel multifuncional y pizarra modular, que gracias a su diseño moderno sin marco y con fijación magnética, permite colocarlas en vertical y horizontal haciendo posibles infinitas composiciones, desde una unidad hasta cubrir una pared, creciendo según sus necesidades. Además, sus acabados y complementos aumentan su funcionalidad con múltiples usos.

- Superficie realizada en chapa de acero de 1mm de espesor
- Bandeja para rotuladores realizada en chapa de acero de 1mm de espesor
- No tiene marco
- Plantilla de instalación realizada en cartón (facilita el proceso de instalación)

**[DE]** Beliebige große Whiteboard-Flächen ohne störende Zwischenrahmen- die innovativen Skin Whiteboard Module ermöglichen eine funktionelle und beliebig große Form der Wandausgestaltung: Als großzügige Schreibfläche, als Kreativwand, als Ausstellungsfläche, als Organisationsmittel... Das klare, rahmenlose Tafel-Design ermöglicht eine fast ansatzlose Flächenausgestaltung, auch im 90° Winkel über Eck. Skin whiteboards können wahlweise horizontal oder vertikal auf Stoß montiert werden. Transport und Montage sind aufgrund des modularen Prinzips und eines magnetischen Montagesystems einfach, schnell und passgenau von nur einer Person zu bewerkstelligen.

- Oberfläche und Ablageboard aus 1mm starkem Stahlblech
- Beliebige große Flächen mit nur zwei Standard Modulmaßen
- Magnethaftend
- Oberfläche mit Boardmarkern trocken oder feucht abwischbar
- Zwei Oberflächenqualitäten: Skin / Skin Color und Skin PRO
- Rahmenloses, puristisches Tafeldesign
- GS geprüft

**[ENG]** The SkinWHITEBOARD is a multifunctional panel and modular whiteboard which, thanks to its modern, frameless design, and magnetic securing, can be placed either vertically or horizontally. This enables greater flexibility on size and layout, from a single unit up to covering a whole wall, modify as needed. In addition a choice of finishes and accessories increase functionality with a myriad of uses.

- Surface made of 1 mm thick sheet steel
- Pen tray made of 1 mm thick sheet steel
- Frameless
- Cardboard Installation template (to facilitate the installation process)

**[FR]** Le SkinWHITEBOARD est très fonctionnel et modulable. Grâce à son design sans cadre et son système d'accroche innovant, il peut être positionné verticalement ou horizontalement. C'est un produit avec une grande flexibilité. Avec une seule référence il est possible de recouvrir un mur entier. Un grand nombre d'accessoires permet de rendre nos tableaux encore plus fonctionnels.

- Surface fait dans une feuille d'acier d'1 mm d'épaisseur.
- Plumier fait dans une feuille d'acier d'1 mm d'épaisseur.
- Sans cadre.
- Gabarit fourni.





3 medidas estándares / 3 standard sizes  
 55x75x1cm · 75x115x1cm · 100x150x1cm

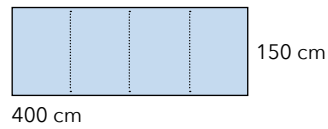
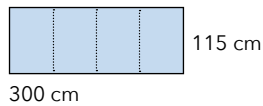
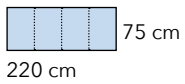
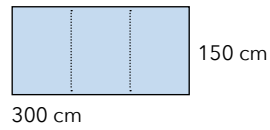
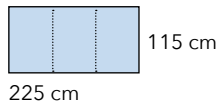
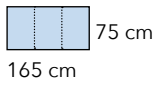
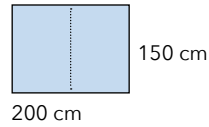
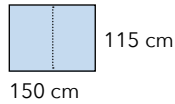
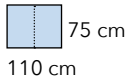
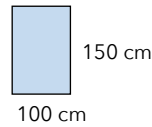
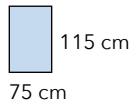
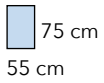

Otros ejemplos / Other examples

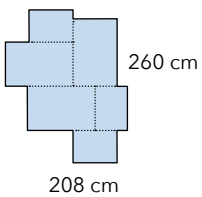

Con 3 SkinWhiteBoard 55x75 cm + 3 SkinWhiteBoard 75x115 cm.  
 With 3 SkinWhiteBoard 55x75 cm + 3 SkinWhiteBoard 75x115 cm.

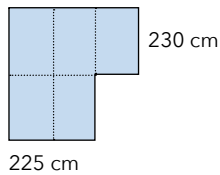

Con 5 SkinWhiteBoard 75x115 cm.  
 With 5 SkinWhiteBoard 75x115 cm.

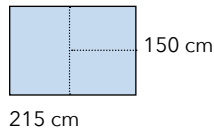

Con 2 SkinWhiteBoard 75x115 cm + 1 SkinWhiteBoard 100x150 cm.  
 With 2 SkinWhiteBoard 75x115 cm + 1 SkinWhiteBoard 100x150 cm.

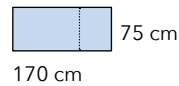

Con 1 SkinWhiteBoard 75x115 cm + 1 SkinWhiteBoard 55x75 cm.  
 With 1 SkinWhiteBoard 75x115 cm + 1 SkinWhiteBoard 55x75 cm.

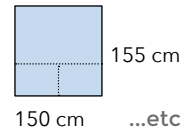

Con 1 SkinWhiteBoard 100x150 cm + 2 SkinWhiteBoard 55x75 cm.  
 With 1 SkinWhiteBoard 100x150 cm + 2 SkinWhiteBoard 55x75 cm.



# ¡Fácil transporte!

Easy to transport! / Einfacher Transport! / Facile à transporter!

**[ESP]** Los paneles **SkinWHITEBOARD** pueden ser:

- Transportados en coche
- Movidos por una sola persona
- Subidos en el ascensor
- Instalados por una persona no especializada
- Sin bordes
- Ilimitados
- Plazos de entrega cortos
- Sin incidencias de transporte

**[DE]** Insbesondere gegenüber großflächigen Einzeltafeln bieten skin whiteboards folgende Vorteile:

- Transport sogar im PKW möglich
- Ein-Personen-Handling
- Im Fahrstuhl transportierbar
- Keine speziellen Montagekenntnisse erforderlich
- Keine Maximal-Abmessungen
- Kurzfristige Lieferzeiten
- Transportrisiko gen Null

**[FR]** Ces tableaux blancs sont :

- Transportables par voiture
- Simples à déplacer (même seul)
- Très simples à installer
- Sans angles
- Modulables à l'infinie
- Livrés très rapidement
- Très bien emballés (pas de problème lors du transport)

**[ENG]** The large format panels can be:

- Transported by car
- Moved by a single person
- Taken up in an elevator
- Installed by non-specialized personnel
- No edges
- Unlimited
- Short delivery deadline
- 0 transport incidents



# ¿Cómo se monta?

How is it set up? / Wie erfolgt die Montage? / Comment l'installer?

**[ESP]** Su facilidad y sencillez de montaje son únicos. 3 sencillos pasos y unos pocos minutos bastan para completar su instalación.

**[ENG]** Very easy and simple to build. 3 easy steps, just a few minutes to complete the installation.

**[DE]** Einfach und schnell in 3 Schritten:

1. Bohren der Montagelöcher gem. Bohrschablone
2. Anbringen der Magnet-Halterungen
3. Aufsetzen der Tafelmodule und ggfs. Ausrichten

**[FR]** Très simple à installer. 3 étapes simples, juste quelques minutes pour faire l'installation complète.

VIDEO



# SkinCERAMIC

(Pizarra modular vitrificada / Enamelled modular whiteboard  
 Emailliert Whiteboard Modul / Tableau modulable vitrifié)

**[ESP]** Gracias a su nuevo acabado vitrificado, la SkinCERAMIC permite ser utilizada en los entornos más exigentes como escuelas, institutos y aulas de formación donde la escritura es continua. Su superficie realizada en chapa de acero vitrificado permite una escritura continua con un mantenimiento mínimo y con una máxima garantía.

**[ENG]** Thanks to its new vitrified finish, the SkinCERAMIC allows to be used in the most demanding environments such as schools, institutes, and training rooms... where writing is continuous. Its surface is made of vitrified steel sheet which allows a continuous writing with minimal maintenance and with a maximum guarantee.

**[DE]** Dank ihrer neuen emaillierten Ausführung eignet sich die Produktreihe SkinCERAMIC bestens für den Einsatz in besonders anspruchsvollen Umgebungen wie Schulen, Gymnasien, Ausbildungsräumen usw., in denen fortwährend geschrieben wird. Die Oberfläche aus emailliertem Stahlblech ermöglicht das fortwährende Beschreiben in Verbindung mit minimalem Wartungsaufwand und maximaler Garantie.



**[FR]** Grâce à sa nouvelle finition vitrifiée, SkinCERAMIC peut être utilisé dans les environnements les plus exigeants comme les écoles, les collèges, les salles de formation, etc. où l'écriture est constante. Sa surface en tôle d'acier vitrifié est idéale pour une écriture continue avec un entretien minimum et une garantie maximum.



Skinwhiteboard, unlimited whiteboard



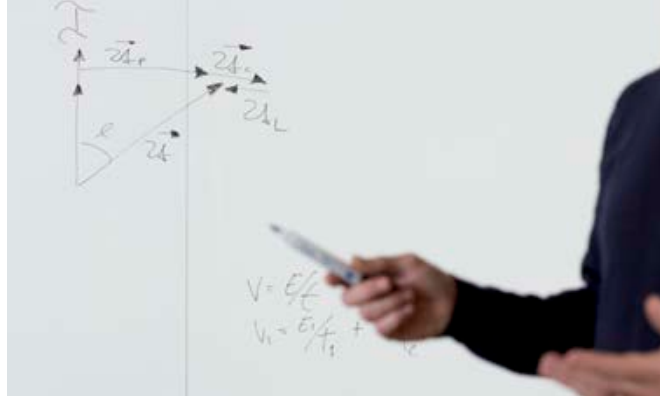
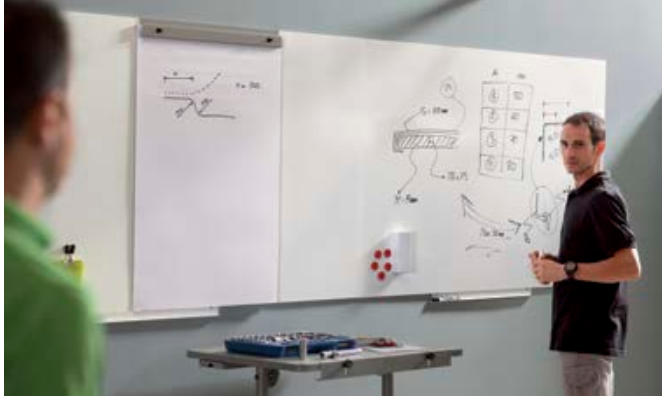

- 25 años de garantía (sólo superficie - para uso diario)
- 25 years warranty (Surface only - For daily use)
- 25 Jahre Oberflächen-Garantie bei richtiger Anwendung
- 25 ans de garantie\* (\*seulement la surface- pour une usage journalier)

Sistema de sujeción que mantiene la superficie plana. Gracias a este sistema, se salvan fácilmente las irregularidades de la pared.

Subjection system that keeps the surface flat. Thanks to this system, the irregularities of the wall are easily overcome.





Incluye un rotulador  
Marker included

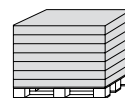
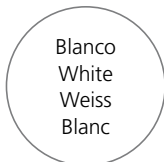

Superficie para rotuladores de borrado en seco.  
Dry wipe surface.  
Trocken abwischbare Oberfläche.  
Surface effaçable à sec.

ACABADOS / FINISHES / DEKORE / FINITIONS



RD-6620CER - palet / pallet 30 u. - 85x125x145 cm  
RD-6621CER - palet / pallet 30 u. - 110x160x165 cm

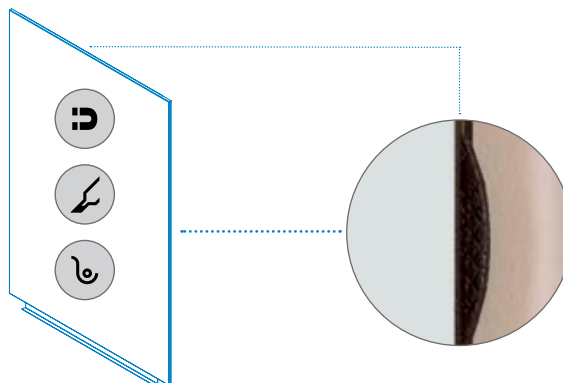
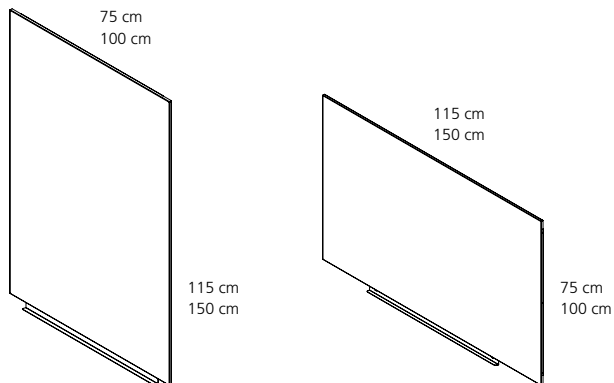

\*Vitrificada / enamelled / emailliert / vitrifié

Recomendada para uso diario / recommended for daily use

Ref.	cm (embalaje / packaging)	kg / m <sup>3</sup> (embalaje / packaging)
RD-6620CER (75x115 cm)	136x96x3	17,30 kg / 0,040 m <sup>3</sup>
RD-6621CER (100x150 cm)	170x121x3	24,00 kg / 0,062 m <sup>3</sup>

Para otras medidas y acabados consultar a Rocada / For other sizes and finishes consult Rocada

# SkinPRO (Pizarra modular / Modular whiteboard)

## Protección adicional de la superficie • Additional surface protection Zusätzliche Oberflächen-Versiegelung • Surface de protection supplémentaire

**[ESP]** Gracias a su nuevo acabado especial con una protección adicional de la superficie realizado en material polimérico, la **SkinPRO** permite ser utilizada en los entornos más exigentes como escuelas, institutos y aulas de formación donde la escritura es continua. Su superficie permite una escritura continua con un mantenimiento mínimo y con una máxima garantía.

**[ENG]** Thanks to its new special finish with additional surface protection made of polymer material, the **SkinPRO** allows it to be used in the most demanding environments such as schools, institutes, and training rooms... where writing is continuous. Its surface allows a continuous writing with a minimum maintenance and with a maximum guarantee.

**[DE]** Dank ihrer neuen Sonderausführung mit einem zusätzlichen Polymer-Oberflächenschutz eignet sich die Reihe **SkinPRO** hervorragend für den Einsatz in besonders anspruchsvollen Umgebungen wie Schulen, Gymnasien, Ausbildungsräumen usw., in denen fortwährend geschrieben wird. Diese Oberfläche ermöglicht das fortwährende Beschreiben in Verbindung mit minimalem Wartungsaufwand und maximaler Garantie.

**[FR]** Grâce à sa nouvelle finition spéciale équipée d'une protection supplémentaire de la surface en matériau polymère, **SkinPRO** peut être utilisé dans les environnements les plus exigeants comme les écoles, les collèges, les salles de formation, etc. où l'écriture est constante. Sa surface est idéale pour une écriture continue avec un entretien minimum et une garantie maximum.

Skinwhiteboard, unlimited whiteboard

años de garantía  
**15**  
years guarantee

15 años de garantía (sólo superficie - para uso diario)

15 years warranty (Surface only - For daily use)

15 Jahre Oberflächen-Garantie bei richtiger Anwendung

15 ans de garantie\* (\*seulement la surface- pour une usage journalier)

NEW

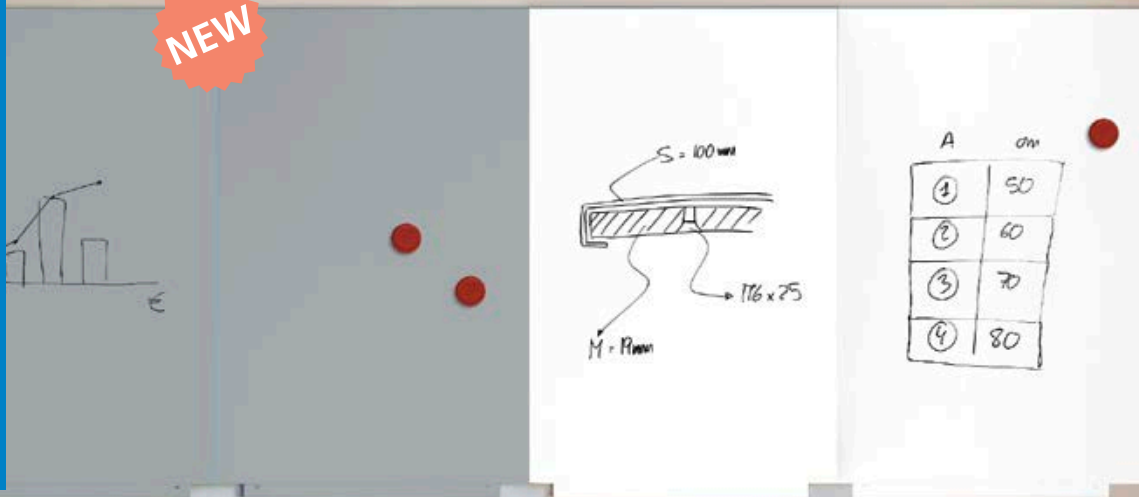



Incluye un rotulador  
Marker included



Superficie para rotuladores de borrado en seco.  
Dry wipe surface.  
Trocken abwischbare Oberfläche.  
Surface effaçable à sec.

ACABADOS SUPERFICIE PRO / PRO SURFACE FINISHES  
DEKORE OBERFLÄCHE PRO / FINITIONS SURFACE PRO

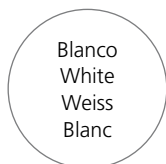

RD-6520PRO  
RD-6521PRO



RD-6520PRO-9006  
RD-6521PRO-9006

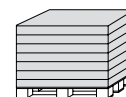

RD-6520PRO - palet / pallet 40 u. - 85x125x145 cm  
RD-6521PRO - palet / pallet 40 u. - 110x160x165 cm



115 cm  
150 cm

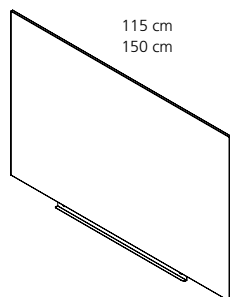

75 cm  
100 cm

RD-6430R

Accesorio bloque de papel / Paper block accessory  
20 hojas de 70gr / 20 sheets of 70gr



100 cm  
65 cm

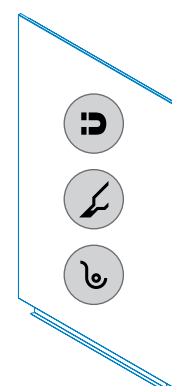

Lacada para rotulador / Lacquered for marker / Für Boardmarkeranwendungen beschichtet / Surface laqué pour des feutres effaçables.

Ref.	cm (embalaje / packaging)	kg / m <sup>2</sup> (embalaje / packaging)
○ RD-6520PRO (75x115 cm)	124x84x3	8,15 kg / 0,031 m <sup>3</sup>
○ RD-6521PRO (100x150 cm)	159x109x3	16,10 kg / 0,052 m <sup>3</sup>
● RD-6520PRO-9006 (75x115 cm)	124x84x3	8,15 kg / 0,031 m <sup>3</sup>
● RD-6521PRO-9006 (100x150 cm)	159x109x3	16,10 kg / 0,052 m <sup>3</sup>

Para otras medidas y acabados consultar a Rocada / For other sizes and finishes consult Rocada

# SkinCOLOUR

(Pizarra modular lacada / Lacquered modular whiteboard  
Lackiertes Whiteboard Modul / Tableau modulable laqué)

**[ESP]** Ordena las tareas por colores, personaliza los departamentos de tu empresa, mejora la visualización de la información, etc. Los diferentes acabados totalmente compatibles con los rotuladores de borrado en seco combinan perfectamente con todo tipo de entornos y además darán un toque moderno y fresco a tu oficina.

**[ENG]** It arranges tasks by colour, personalizes company departments, improves visualization of information... The different finishes are fully compatible with dry-erase markers, blend in perfectly with any environment and also give a fresh and modern touch to your office.

**[DE]** Mit Farbe lässt sich viel ausdrücken und darstellen—unterschiedliche Bereiche oder Informationsschwerpunkte, Stimmungen oder einfach nur individueller Geschmack. Skin Color Schreiftafeln sind fast genauso funktionell wie die weißen Tafelmodule, bringen aber deutlich mehr Farbe in's (Büro)Leben.

**[FR]** Ces tableaux permettent d'organiser les tâches grâce aux différentes couleurs. Ils personnalisent l'entreprise tout en améliorant la visualisation des informations. Les différentes finitions sont compatibles avec les marqueurs effaçables, ils sont parfait pour donner une touche fraîche et moderne à votre bureau.

**NEW**

Skinwhiteboard, unlimited whiteboard

5 años de garantía  
5 years warranty  
5 Jahre Oberflächen-Garantie  
5 ans de garantie

**5 años de garantía** (sólo superficie - para uso frecuente)  
**5 years warranty** (Surface only - For common use)  
**5 Jahre Oberflächen-Garantie** bei normaler Anwendung  
**5 ans de garantie\*** (\*seulement la surface - pour un usage courant).

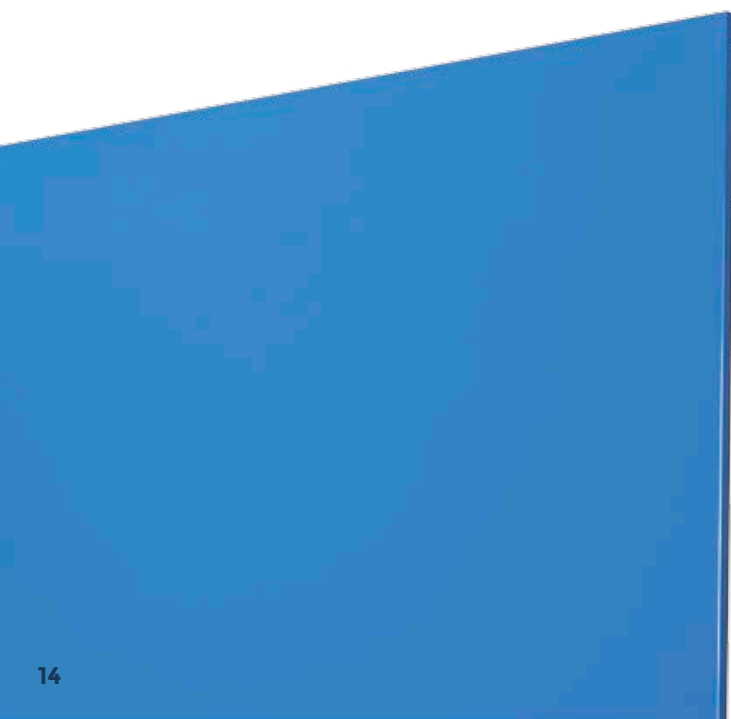

**RD-6420R-630**

Referencia medida  
Size reference

Colour RAL



Incluye un rotulador  
Marker included



Admite rotulador de tiza líquida. No limpiar con alcohol o productos abrasivos

Allows liquid chalk markers  
Never clean it with alcohol or abrasive products.



ACABADOS ESTÁNDAR / STANDARD FINISHES  
STANDARD-DEKORE / FINITIONS STANDARD

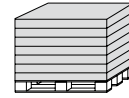
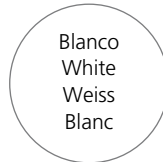

RD-6419R · RD-6420R · RD-6421R

RD-6419R - palet / pallet 50 u. - 80x120x145 cm  
RD-6420R - palet / pallet 40 u. - 85x125x145 cm  
RD-6421R - palet / pallet 40 u. - 110x160x165 cm

ACABADOS BAJO PEDIDO / UNDER REQUEST FINISHES / DEKORE AUF ANFRAGE / FINITIONS SUR DEMANDE

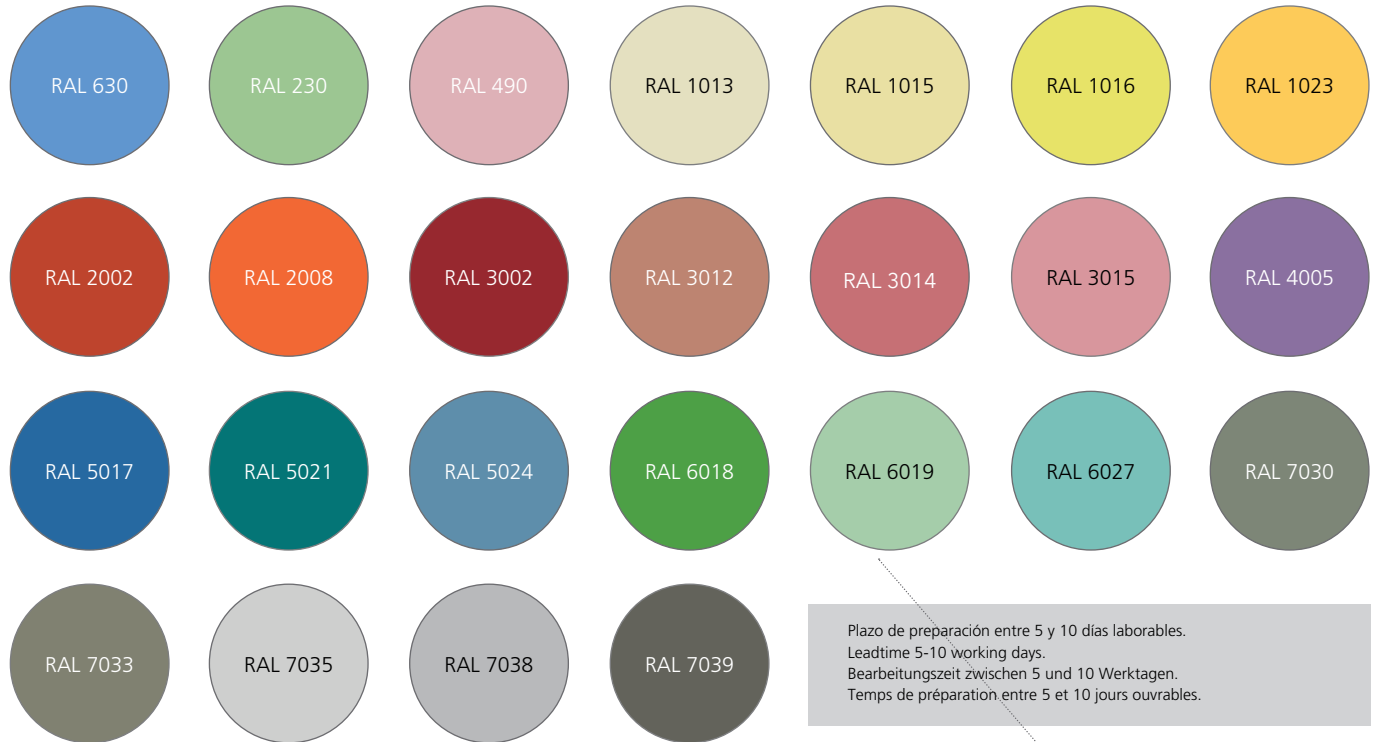

Plazo de preparación entre 5 y 10 días laborables.  
Leadtime 5-10 working days.  
Bearbeitungszeit zwischen 5 und 10 Werktagen.  
Temps de préparation entre 5 et 10 jours ouvrables.

Skinwhiteboard, unlimited whiteboard

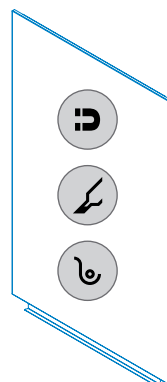
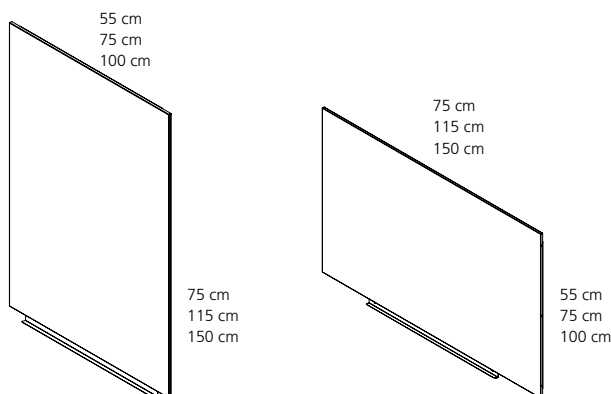

Superficie para rotuladores de borrado en seco.  
No limpiar con alcohol o productos abrasivos.  
Dry wipe surface. Never clean it with alcohol or abrasive products.  
Bitte niemals mit reinem Alkohol reinigen und keine Tücher mit abrasiven Eigenschaften verwenden.  
Surface effaçable à sec. Ne nettoyer jamais la surface avec de l'alcool ou un produit abrasif.

Lacada. Superficie borrado en seco. / Lacquered. Dry erase surface. / Lackierte Oberfläche für trocken abwischbare Beschriftungen. / Surface laquée effaçable à sec.

Ref.	cm (embalaje / packaging)	kg / m³ (embalaje / packaging)
○ RD-6419R (55x75 cm)	83x63x3	4,40 kg / 0,016 m³
○ RD-6420R (75x115 cm)	124x84x3	8,15 kg / 0,031 m³
○ RD-6421R (100x150 cm)	159x109x3	16,10 kg / 0,052 m³

Para otras medidas y acabados consultar a Rocada / For other sizes and finishes consult Rocada

# SkinSHAPE

## SkinIDEA / SkinCLOUD / SkinTALK (Lacado / Lacquered / Lackierte / Laquée)

**[ESP]** Los diferentes acabados totalmente compatibles con los rotuladores de borrado en seco y las nuevas formas darán un toque moderno y fresco a tu oficina.

**[ENG]** The different finishes are fully compatible with dry-wipe markers and the new SkinSHAPE range will bring a fresh and inspirational touch to your office.

**[DE]** Die Auswahl an Formen und Farben bringt Frische und Inspiration in Ihr Büro oder Ihre Meeting-Zone. Dabei sind die in jeweils zwei Größen erhältlichen Symbol-Tafeln wie die Standardtafeln mit Boardmarkern beschriftbar und magnethaftend. Ausnahme: die schwarz pulverbeschichtete Ausführung ist nur mit Kreide oder Kreidemarkern beschriftbar. Zu jedem Shape-Modul gehört ein Ablageboard mit fixierter Montageposition.

**[FR]** Les nouveaux designs de la gamme SkinSHAPE rendent les idées et la communication plus vivantes.

NEW

Skinwhiteboard, unlimited whiteboard

5 años de garantía  
5 years warranty  
5 Jahre Oberflächen-Garantie  
5 ans de garantie\*

**5 años de garantía** (sólo superficie - para uso frecuente)  
**5 years warranty** (Surface only - For common use)  
**5 Jahre Oberflächen-Garantie** bei normaler Anwendung  
**5 ans de garantie\*** (\*seulement la surface - pour un usage courant).

Medidas / Sizes (cm)

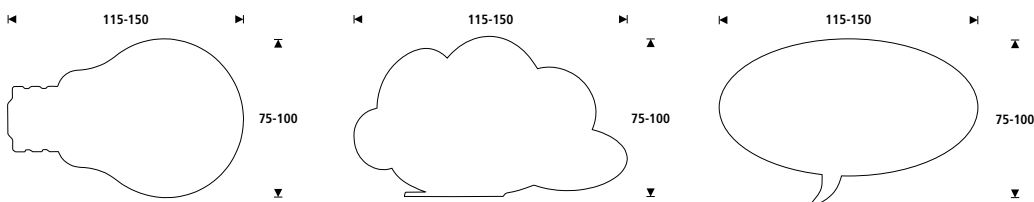

Lacada para rotulador / Lacquered for marker / Für Boardmarkeranwendungen beschichtet / Surface laqué pour des feutres effaçables.

IDEA	CLOUD	TALK	cm (producto / product)	cm (embalaje / packaging)	kg / m <sup>3</sup> (embalaje / packaging)
RD-6460	RD-6450	RD-6440	75x115	124x84x3	8,15 kg / 0,030 m <sup>3</sup>
RD-6461	RD-6451	RD-6441	100x150	159x109x3	16,10 kg / 0,052 m <sup>3</sup>

Para otras medidas y acabados consultar a Rocada / For other sizes and finishes consult Rocada















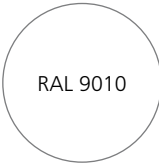

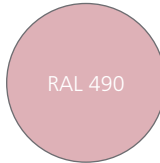
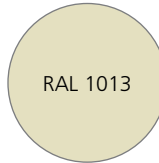
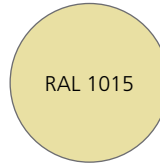
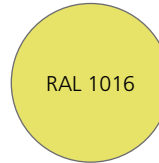
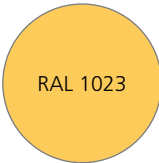

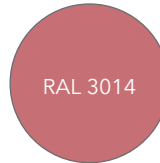
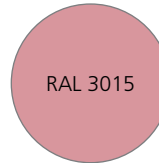

Incluye un rotulador  
Marker included

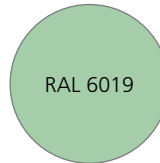
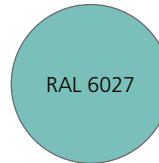

Admite rotulador de tiza líquida.  
No limpiar con alcohol o productos  
abrasivos

Allows liquid chalk markers  
Never clean it with alcohol or abrasive  
products.

ACABADOS BAJO PEDIDO / UNDER REQUEST FINISHES / DEKORE AUF ANFRAGE / FINITIONS SUR DEMANDE

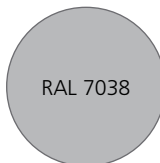
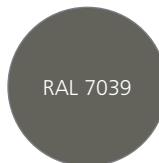
 RAL 9010	 RAL 630	 RAL 230	 RAL 490	 RAL 1013	 RAL 1015	 RAL 1016
 RAL 1023	 RAL 2002	 RAL 2008	 RAL 3002	 RAL 3012	 RAL 3014	 RAL 3015
 RAL 4005	 RAL 5017	 RAL 5021	 RAL 5024	 RAL 6018	 RAL 6019	 RAL 6027
 RAL 7030	 RAL 7033	 RAL 7035	 RAL 7038	 RAL 7039	<p>Plazo de preparación entre 5 y 10 días laborables. Leadtime 5-10 working days. Bearbeitungszeit zwischen 5 und 10 Werktagen. Temps de préparation entre 5 et 10 jours ouvrables.</p>	

Lacada. Superficie borrado en seco. / Lacquered. Dry erase surface. / Lackierte Oberfläche für trocken abwischbare Beschriftungen. / Surface laquée effaçable à sec.

Superficie para rotuladores de borrado en seco.  
No limpiar con alcohol o productos abrasivos.

Dry wipe surface. Never clean it with alcohol or abrasive products.

Bitte niemals mit reinem Alkohol reinigen und keine Tücher mit abrasiven  
Eigenschaften verwenden.

Surface effaçable à sec. Ne nettoyer jamais la surface avec de l'alcool ou un  
produit abrasif.



**RD-6440-230**

Referencia medida  
Size reference

Colour RAL

# SkinAGILE

(Pizarra modular lacada / Lacquered modular whiteboard  
Lackiertes Whiteboard Modul / Tableau modulable laqué)

**[ESP]** SkinAGILE permite aplicar diferentes metodologías para el desarrollo de proyectos que precisan de rapidez y flexibilidad para adaptarse a condiciones cambiantes del sector o mercado.

**[ENG]** SkinAGILE allows applying different methodologies for the development of projects that require speed and flexibility to adapt to changing conditions in the sector or market.

**[DE]** SkinAGILE erlaubt die Anwendung verschiedener Methoden zur Ausführung von Projekten, bei denen Schnelligkeit und Flexibilität gefordert sind, um sich an die wechselnden Bedingungen des jeweiligen Sektors oder Markts anpassen zu können.

**[FR]** SkinAGILE permet d'appliquer différentes méthodologies pour le développement de projets requérant rapidité et flexibilité afin de s'adapter aux conditions changeantes du secteur ou du marché.

NEW

TO DO

DOING

Skinwhiteboard, unlimited whiteboard

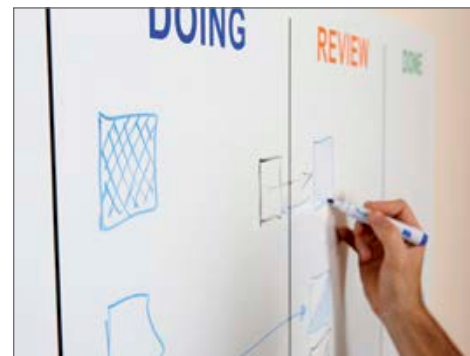

Superficie para rotuladores de borrado en seco.  
No limpiar con alcohol o productos abrasivos.

Dry wipe surface. Never clean it with alcohol or abrasive products.

Bitte niemals mit reinem Alkohol reinigen und keine Tücher mit abrasiven Eigenschaften verwenden.

Surface effaçable à sec. Ne nettoyer jamais la surface avec de l'alcool ou un produit abrasif.



RD-S4323MX  
(20x10cm)

RD-S4324MX  
(12,5x12,5cm)



Skinny Notes incluida / included



Incluye un rotulador  
Marker included

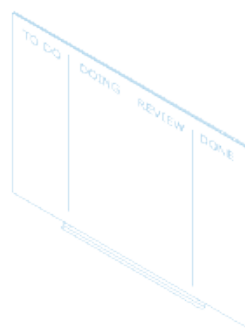
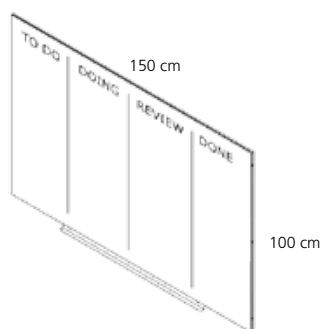

Lacada para rotulador / Lacquered for marker / Für Boardmarkeranwendungen beschichtet / Surface laqué pour des feutres effaçables.

Ref.	cm (embalaje / packaging)	kg / m <sup>3</sup> (embalaje / packaging)
RD-6421AG (100x150 cm)	159x109x3	16,10 kg / 0,052 m <sup>3</sup>

Para otras medidas y acabados consultar a Rocada / For other sizes and finishes consult Rocada

# SkinCUBE

(Lacado / Lacquered / Lackierte / Laquée)

**[ESP]** El intercambio de información requiere soluciones de gestión visual (visual management) que se actualizan tan rápido y eficientemente como sea posible. SkinCUBE nace con esta idea. Realizado con una estructura interior en DM y panelado con chapa de acero lacada.

**[ENG]** The exchange of information requires visual management solutions that are updated as quickly and as efficiently as possible. SkinCUBE was born with this idea. Made with MDF interior structure and paneling of lacquered steel sheet.

**[DE]** Der Informationsaustausch macht Lösungen im Bereich Visual Management erforderlich, die sich möglichst schnell und wirksam aktualisieren. Genau auf dieser Idee basiert SkinCUBE. Gefertigt mit einer MDF-Platte als Innenstruktur sowie einer Täfelung aus lackiertem Stahlblech.

**[FR]** L'échange d'informations exige des solutions de gestion visuelle (visual management) capables d'être mises à jour aussi rapidement et efficacement que possible. SkinCUBE est né de cette idée. Il comporte une structure intérieure en DM et en revêtement en tôle d'acier laqué.

NEW

Skinwhiteboard, unlimited whiteboard





Superficie para rotuladores de borrado en seco.  
No limpiar con alcohol o productos abrasivos.

Dry wipe surface. Never clean it with alcohol or abrasive products.

Bitte niemals mit reinem Alkohol reinigen und keine Tücher mit abrasiven Eigenschaften verwenden.

Surface effaçable à sec. Ne nettoyer jamais la surface avec de l'alcool ou un produit abrasif.



Ruedas con sistema de freno  
Wheels with brake system

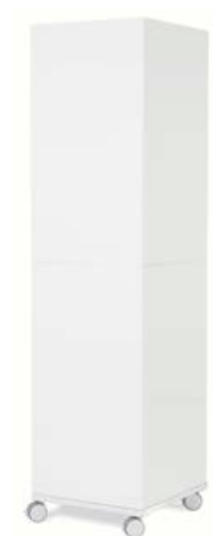
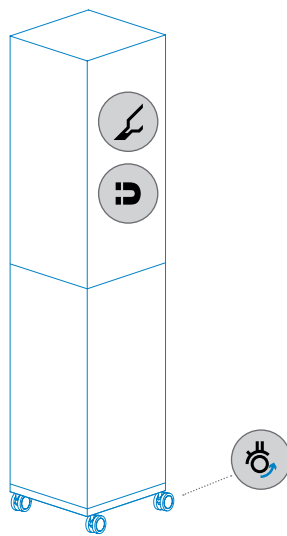
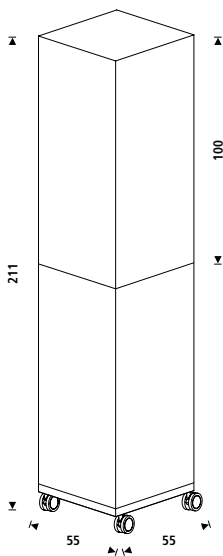

Lacada para rotulador / Lacquered for marker / Für Boardmarkeranwendungen beschichtet / Surface laqué pour des feutres effaçables.

Ref.	cm (embalaje / packaging)	kg / m <sup>3</sup> (embalaje / packaging)
RD-6876S4	130x120x80	81,45 kg / 1,248 m <sup>3</sup>

Para otras medidas y acabados consultar a Rocada / For other sizes and finishes consult Rocada

# SkinMATT

(Pizarra modular lacada / Lacquered modular whiteboard  
Lackiertes Whiteboard Modul / Tableau modulable laqué)

**[ESP]** Gracias a su nuevo acabado mate, la **SkinMATT** permite ser utilizada como pantalla de proyección. Su acabado final mate totalmente compatible con los rotuladores de borrado en seco también permite ser utilizado como pizarra de pared.

**[ENG]** Thanks to its new matte finish, **SkinMATT** can be used as a projection screen. Its matte is fully compatible with dry-wipe markers. Can also be used as a wall whiteboard.

**[DE]** Die Oberflächenausführung **SkinMATT** ist speziell als Projektionsfläche konzipiert und bietet sich insbesondere für die Verwendung von Kurzstanzbeamern an. Magnethaftend und begrenzt auch für die Verwendung von Boardmarkern geeignet.

**[FR]** Grâce à sa nouvelle finition mate, **SkinMATT** peut être utilisé comme support de projection. Son revêtement mat est entièrement compatible avec les marqueurs effaçables à sec. Peut également être utilisé comme un tableau blanc classique.

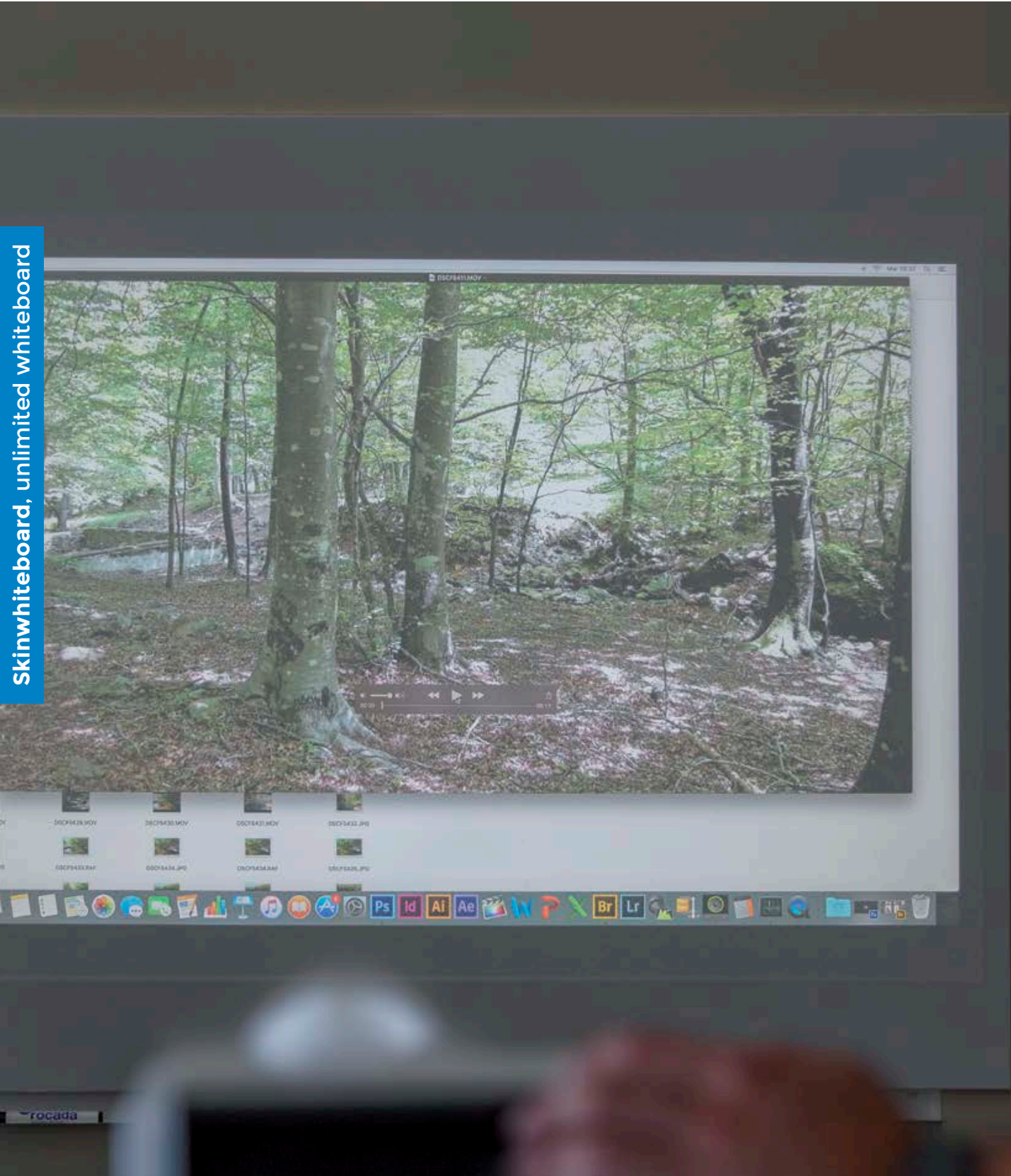

Skinwhiteboard, unlimited whiteboard



Superficie para rotuladores de borrado en seco.  
No limpiar con alcohol o productos abrasivos.

Dry wipe surface. Never clean it with alcohol or abrasive products.

Bitte niemals mit reinem Alkohol reinigen und keine Tücher mit abrasiven Eigenschaften verwenden.

Surface effaçable à sec. Ne nettoyer jamais la surface avec de l'alcool ou un produit abrasif.

La pizarra SkinMATT se adapta perfectamente al formato de proyección 4:3, pudiendo crear una imagen de tamaño un 25% más grande que con las pizarras mate convencionales cuya altura máxima es tan sólo de 120cm.

The SkinMATT fits perfectly into the 4:3 projection format, creating an image size by 25% bigger than the conventional matt whiteboards whose maximum height is only 120cm.

Ejemplo / Example

Imagen con SkinMATT  
SkinMATT image

Imagen con PIZARRA CONVENCIONAL  
CONVENTIONAL MATT WHITEBOARD Image

200 x 150

200 x 120



RD-S4319V19

Kit de limpieza y accesorios Skin  
Cleaning kit and accessories

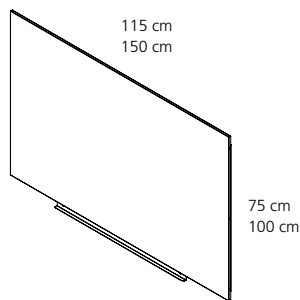
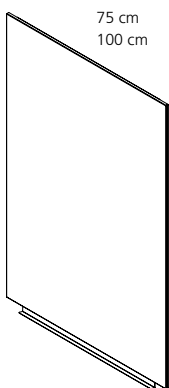

RD-6430R

Accesorio bloque de papel / Paper block accessory  
20 hojas de 70gr / 20 sheets of 70gr

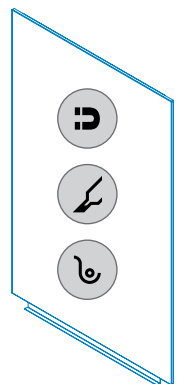
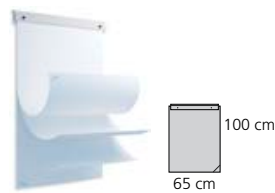

Lacada para rotulador / Lacquered for marker / Für Boardmarkeranwendungen beschichtet / Surface laqué pour des feutres effaçables.

Ref.	cm (embalaje / packaging)	kg / m <sup>3</sup> (embalaje / packaging)
RD-6420MATT (75 x 115 cm)	124x84x3	8,15 kg / 0,031 m <sup>3</sup>
RD-6421MATT (100 x 150 cm)	159x109x3	16,10 kg / 0,052 m <sup>3</sup>
RD-6430R (65x90cm) opcional / optional	87x8x8	1,6 kg / 0,005 m <sup>3</sup>

Para otras medidas y acabados consultar a Rocada / For other sizes and finishes consult Rocada

# SkinMUSIC

(Pizarra modular lacada / Lacquered modular whiteboard  
Lackiertes Whiteboard Modul / Tableau modulable laqué)

**[ESP]** Gracias a su nuevo acabado pentagrama y a la modularidad del sistema Skin, convierten a la SkinMUSIC en una de las mejores herramientas para el estudio y la creación de todo tipo de música. Su acabado con pentagrama es totalmente compatible con los rotuladores de borrado en seco.

**[ENG]** Thanks to its new music notation layout and to the Skin system flexibility, SkinMUSIC becomes one of the best tools for studying and creating all kinds of music. Its unique finish is fully compatible with dry-erase markers.

**[DE]** Praktisch für den theoretischen Musik-Unterricht oder die klassische Komponistentätigkeit. Die mit Notenlinien bedruckten Tafelmodule können beliebig aneinandergesetzt werden oder auch mit weißen Tafelmodulen kombiniert werden. Das Modulformat 115x75cm ist mit 5 Notensystemen, das Modulformat 150x100 mit 7 Notensystemen bedruckt.

**[FR]** Grâce à ce nouveau design et au système Skin Flexibilité, le SkinMUSIC devient l'un des meilleurs outils pour étudier et créer toutes sortes de musique. Sa finition unique est entièrement compatible avec les marqueurs effaçables à sec.







Superficie para rotuladores de borrado en seco.  
No limpiar con alcohol o productos abrasivos.

Dry wipe surface. Never clean it with alcohol or abrasive products.

Bitte niemals mit reinem Alkohol reinigen und keine Tücher mit abrasiven Eigenschaften verwenden.

Surface effaçable à sec. Ne nettoyer jamais la surface avec de l'alcool ou un produit abrasif.

RD-6421RMH  
150x100 cm

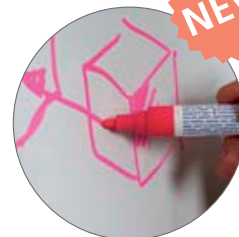

Admite rotulador de tiza líquida. No limpiar con alcohol o productos abrasivos

Allows liquid chalk markers  
Never clean it with alcohol or abrasive products.



Incluye un rotulador  
Marker included



I4319  
Imanes · Magnets



RD-S4300V19  
Borrador · Eraser

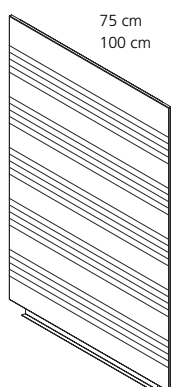

115 cm  
150 cm

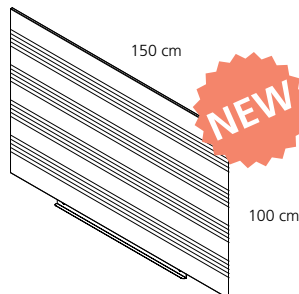

RD-6430R  
Accesorio bloque de papel / Paper block accessory  
20 hojas de 70gr / 20 sheets of 70gr

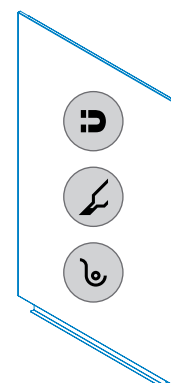

Lacada para rotulador / Lacquered for marker / Für Boardmarkeranwendungen beschichtet / Surface laqué pour des feutres effaçables.

Ref.	cm (embalaje / packaging)	kg / m <sup>3</sup> (embalaje / packaging)
RD-6420RM (75 x 115 cm)	124x84x3	8,15 kg / 0,031 m <sup>3</sup>
RD-6421RM (100 x 150 cm)	159x109x3	16,10 kg / 0,052 m <sup>3</sup>
RD-6421RMH (150 x 100 cm) horizontal	159x109x3	16,10 kg / 0,052 m <sup>3</sup>
RD-6430R (65x90cm) opcional / optional	87x8x8	1,6 kg / 0,005 m <sup>3</sup>

Para otras medidas y acabados consultar a Rocada / For other sizes and finishes consult Rocada

# SkinLIQUID

(Pizarra modular lacada / Lacquered modular whiteboard  
Lackiertes Whiteboard Modul / Tableau modulable laqué)

**[ESP]** Gracias a su nuevo acabado negro, la SkinLIQUID permite ser utilizada como pizarra para tiza líquida ideal para restaurantes, bares y comercios en general. Su excelente modularidad permite crear todo tipo de configuraciones acorde a las necesidades actuales y futuras en la oficina y en casa.

**[ENG]** Thanks to its new black finish, the SkinLIQUID can be used as a whiteboard for liquid chalk. This is ideal for restaurants, bars and shops in general. Its excellent modularity enables creating all kinds of configurations according to current and future needs in the office and at home.

**[DE]** Dank seiner neuen Ausführung in schwarz kann SkinLIQUID als Tafel für flüssige Kreidestifte verwendet werden und eignet sich somit ideal für Restaurants, Bars und Geschäfte verschiedenster Art. Dank seiner hervorragenden Modularität können alle möglichen Konfigurationen erstellt werden, dies entsprechend den aktuellen und zukünftigen Anforderungen im Büro oder daheim

**[FR]** Avec sa nouvelle finition noire, SkinLIQUID peut être utilisé comme tableau à craie liquide : il est idéal pour les restaurants, les bars et plus généralement tout type de commerces. Son excellente modularité permet de créer tout type de configurations en fonction des besoins actuels et futurs, aussi bien au bureau qu'à la maison.

NEW

Skinwhiteboard, unlimited whiteboard





Admite rotulador de tiza líquida. No limpiar con alcohol o productos abrasivos

Allows liquid chalk markers  
Never clean it with alcohol or abrasive products.

x1 x1 x1 x1  
  
**RD-S5050MX**  
 Rotuladores de tiza líquida  
 Liquid chalk markers



Skinwhiteboard, unlimited whiteboard

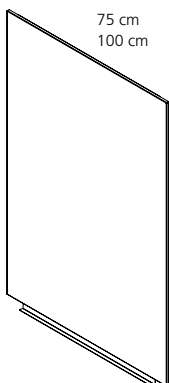

115 cm  
150 cm

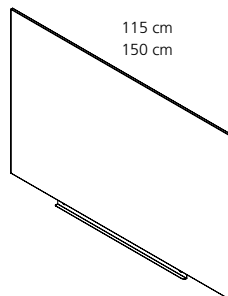

75 cm  
100 cm

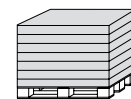
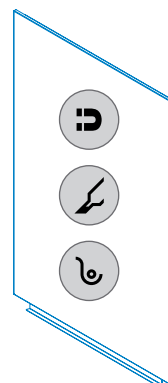

**RD-6820V19** - palet / pallet 40 u. - 85x125x145 cm  
**RD-6821V19** - palet / pallet 40 u. - 110x160x165 cm

Lacada para rotulador / Lacquered for marker / Für Boardmarkeranwendungen beschichtet / Surface laqué pour des feutres effaçables.

Ref.	cm (embalaje / packaging)	kg / m <sup>3</sup> (embalaje / packaging)
<b>RD-6820V19</b> (75x115 cm)	124x84x3	8,15 kg / 0,031 m <sup>3</sup>
<b>RD-6821V19</b> (100x150 cm)	159x109x3	16,10 kg / 0,052 m <sup>3</sup>

Para otras medidas y acabados consultar a Rocada / For other sizes and finishes consult Rocada

# SkinPINBOARD

**[ESP]** Panel modular tapizado sin marco para generar combinaciones y presentaciones que cubran tus necesidades. SkinPINBOARD es sencilla de colocar ahorrando tiempo y dinero.

**[ENG]** Upholstered modular panel without frame to generate combinations and presentations that meet your needs. SkinPINBOARD is simple to place. Saves time and money.

**[DE]** Gepolsterte modulare Tafel ohne Rahmen, um Kombinationen und Präsentationen zu erstellen, die Ihre Anforderungen und Bedürfnisse erfüllen. SkinPINBOARD ist einfach anzubringen. Spart Zeit und Geld.

**[FR]** Panneau modulaire tapissé sans cadre afin de donner lieu à des combinaisons et à des présentations parfaitement adaptées à vos besoins. SkinPINBOARD facile à installer. Économisez du temps et de l'argent.

**NEW**

Skinwhiteboard, unlimited whiteboard

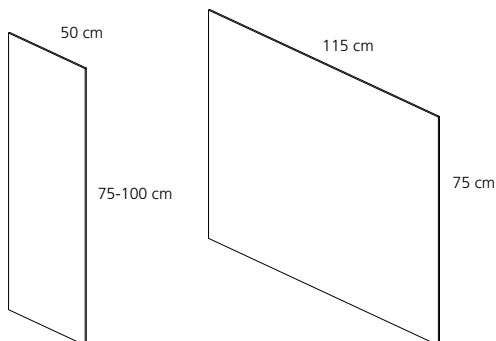
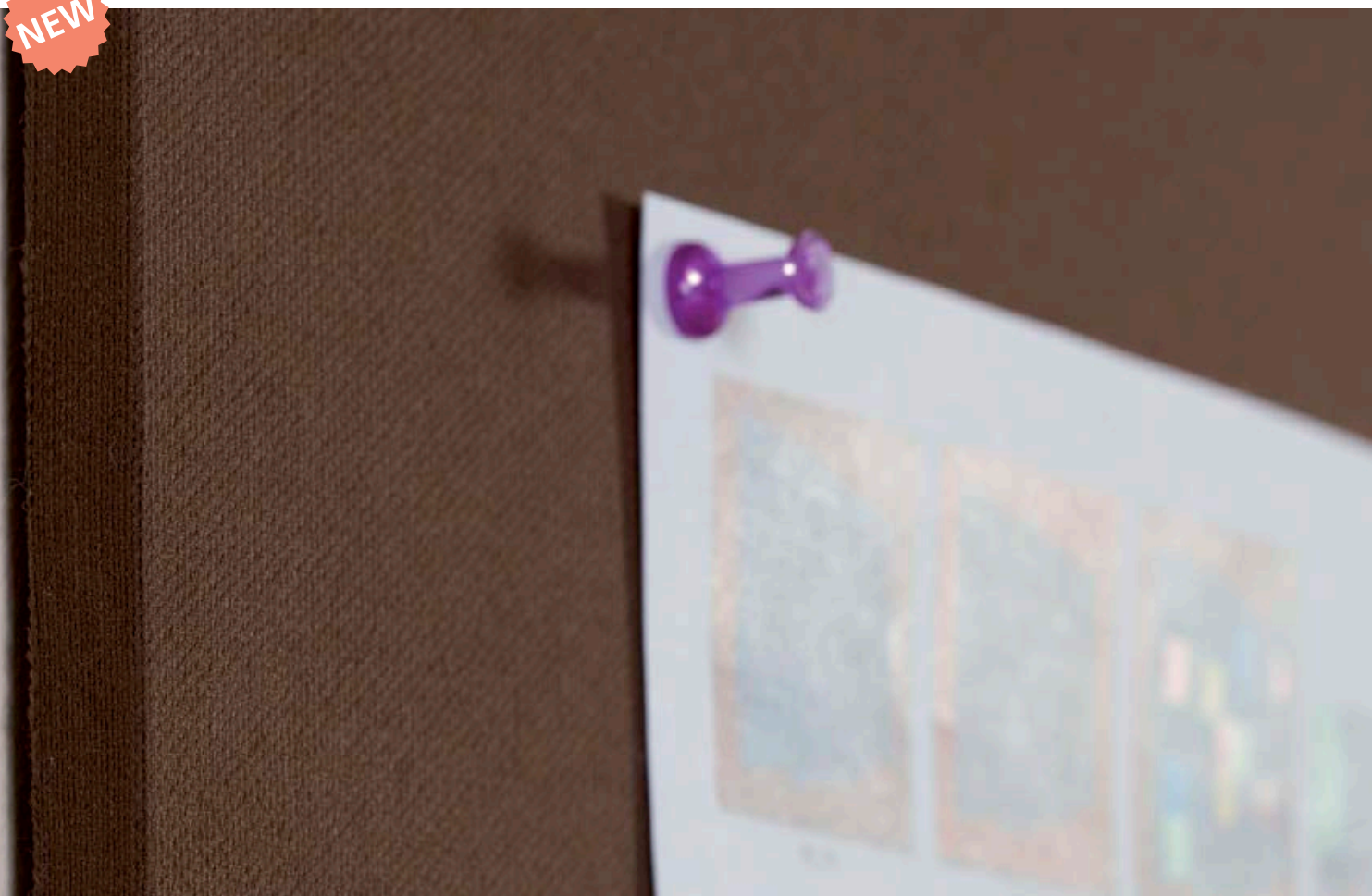

Ref.	cm (embalaje / packaging)	kg / m <sup>3</sup> (embalaje / packaging)
<b>RD-6249</b> (50x75cm)	83x63x3	2,00 kg / 0,016 m <sup>3</sup>
<b>RD-6248</b> (50x100cm)	109x59x3	3,00 kg / 0,019 m <sup>3</sup>
<b>RD-6250</b> (75x115cm)	124x84x3	3,00 kg / 0,031 m <sup>3</sup>

Para otras medidas y acabados consultar a Rocada / For other sizes and finishes consult Rocada



ACABADOS ESTÁNDAR / STANDARD FINISHES / STANDARD-DEKORE / FINITIONS STANDARD

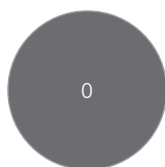

0

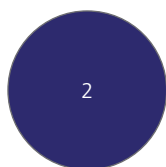

2



510



512



518

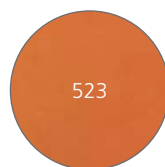

523

**RD-6248-2**

Referencia  
medida  
Size reference

Color / Colour

Skinwhiteboard, unlimited whiteboard



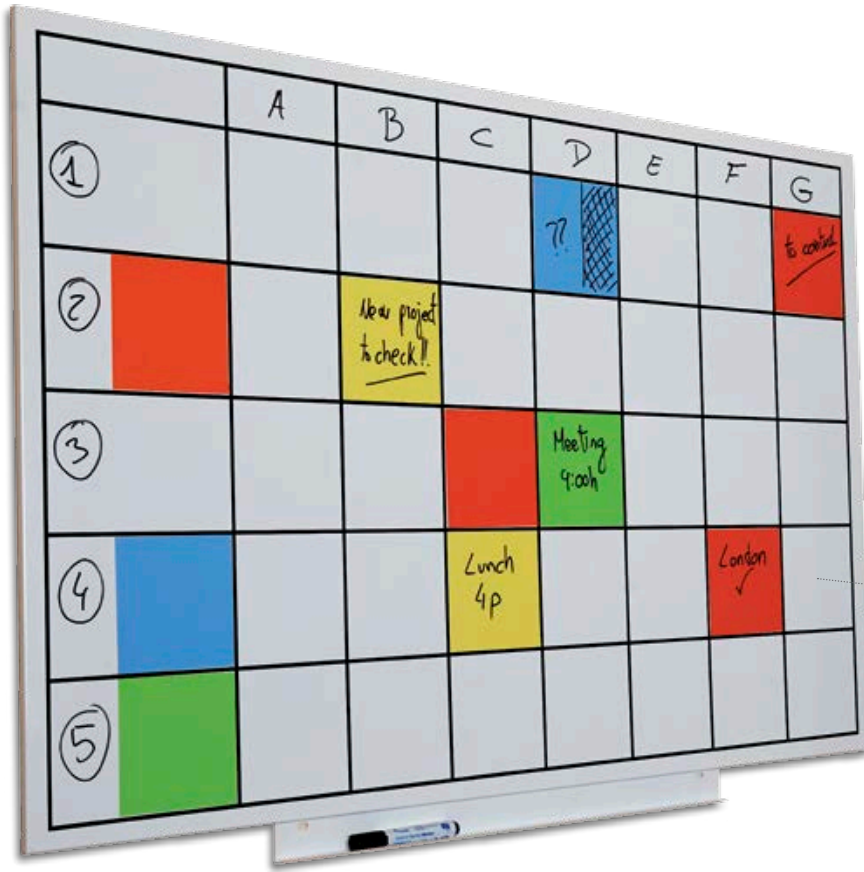

Superficie para rotuladores de borrado en seco.  
No limpiar con alcohol o productos abrasivos.  
Dry wipe surface. Never clean it with alcohol or abrasive products.  
Bitte niemals mit reinem Alkohol reinigen und keine Tücher mit abrasiven Eigenschaften verwenden.  
Surface effaçable à sec. Ne nettoyer jamais la surface avec de l'alcool ou un produit abrasif.



RD-S4323MX  
(20x10cm)



RD-S4324MX  
(12,5x12,5cm)



Skinny Notes incluida / included



Incluye un rotulador  
Marker included

Plantilla adhesiva / Adhesive template

PROJECT	SPRINT	TO DO	DONE	IN PROGRESS	BACKLOG
1					
2					

MONDAY	MONTAG	LUNDI	LUNES
TUESDAY	DIENSTAG	MARDI	MARTES
WEDNESDAY	MITTWOCH	MERCREDI	MIÉRCOLES
THURSDAY	DONNERSTAG	JEUDI	JUEVES
FRIDAY	FREITAG	VENDREDI	VIERNES
SATURDAY	SAMSTAG	SAMEDI	SABADO
SUNDAY	SONNTAG	DIMANCHE	DOMINGO
WEEK	WOCHE	SEMAINE	SEMANA
DAY	TAG	JOUR	DIA
1	2	3	4
5	6	7	8
PROJECT	TO DO	PRIO	SPRINT
TASK	TO DO	PRIO	SPRINT
PROJECT	DONE	BLOCKED	IN PROGRESS
TASK	DONE	BLOCKED	IN PROGRESS
PRODUCT	STORY	NEXT	SPRINT
BACKLOG	STORY	NEXT	BACKLOG
PRODUCT	IN TEST	REVIEW	SPRINT
BACKLOG	IN TEST	REVIEW	BACKLOG

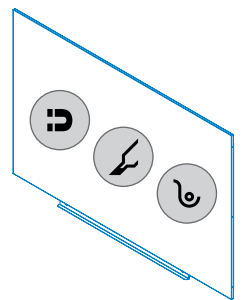
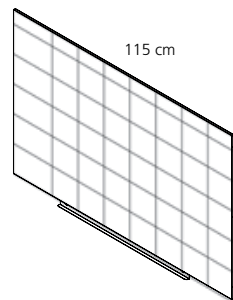
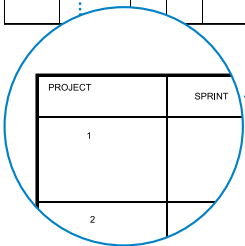

Lacada para rotulador / Lacquered for marker / Für Boardmarkeranwendungen beschichtet / Surface laqué pour des feutres effaçables.

Ref.	cm (embalaje / packaging)	kg / m <sup>3</sup> (embalaje / packaging)
RD-6420YP (75 x 115 cm)	124x84x3	8,15 kg / 0,031 m <sup>3</sup>
RD-6420UP (75 x 115 cm)	124x84x3	8,15 kg / 0,031 m <sup>3</sup>

Para otras medidas y acabados consultar a Rocada / For other sizes and finishes consult Rocada

# SkinCLOCK

(Pizarra modular lacada / Lacquered modular whiteboard  
Lackiertes Whiteboard Modul / Tableau modulable laqué)

**[ESP]** La SkinCLOCK le ayudará a planificar y organizar todo tipo de tareas. Su acabado es totalmente compatible con los rotuladores de borrado en seco. Incluye calendario y reloj analógico de serie.

**[ENG]** The SkinCLOCK will help you plan and organize all kinds of tasks. The finish is fully compatible with dry-wipe markers. It includes a standard analogue clock.

**[DE]** Das praktische Organisationsmittel für eine schnelle Grobübersicht kurzfristiger Termine. Mit integrierter, batteriebetriebener Analog-Uhr. Monatskalendarium, Uhrzeit und Notizfläche machen diese Tafelversion zu einem praktischen Helfer für den Büroalltag.

**[FR]** Le SkinCLOCK vous aidera à planifier et organiser votre journée. La finition est entièrement compatible avec les marqueurs effaçable à sec. Il comprend une horloge analogique standard.

Skinwhiteboard, unlimited whiteboard

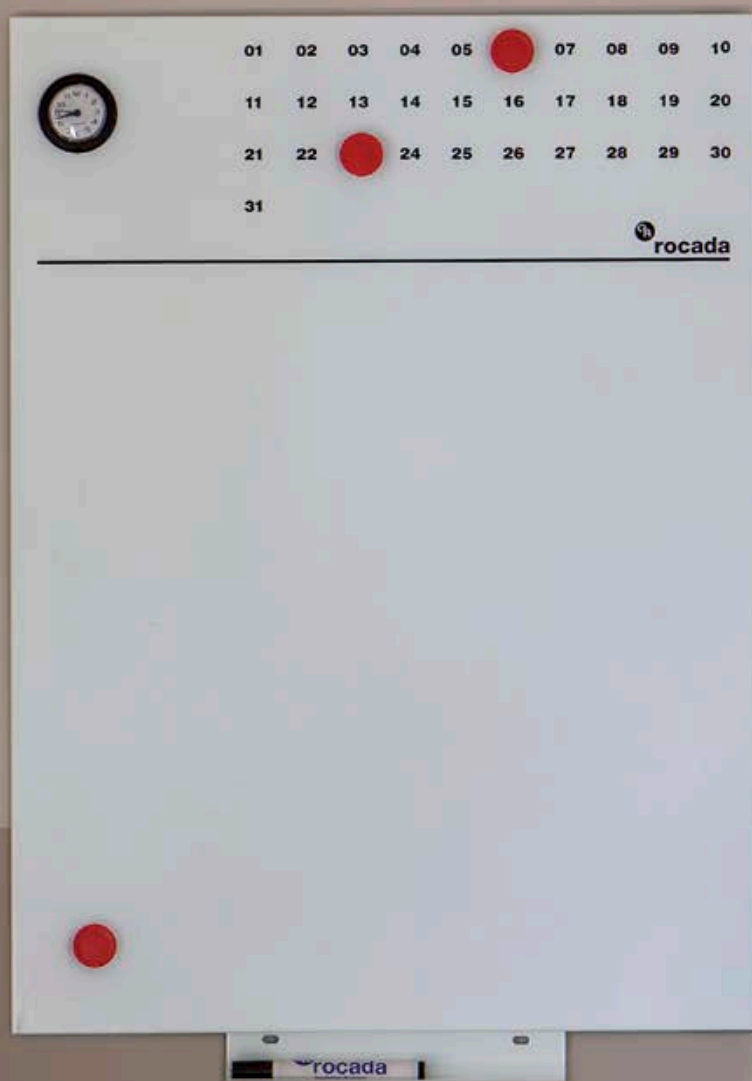



Pila no incluida  
Battery not included

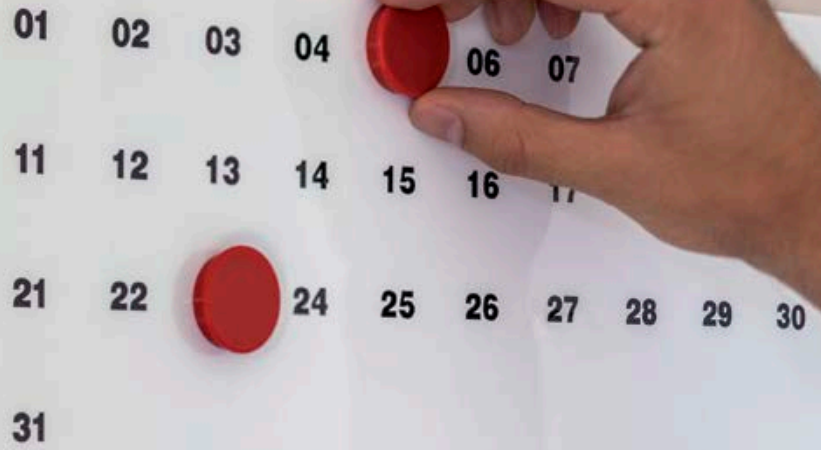

 rocada



Superficie para rotuladores de borrado en seco.  
No limpiar con alcohol o productos abrasivos.

Dry wipe surface. Never clean it with alcohol or abrasive products.

Bitte niemals mit reinem Alkohol reinigen und keine Tücher mit abrasiven Eigenschaften verwenden.

Surface effaçable à sec. Ne nettoyer jamais la surface avec de l'alcool ou un produit abrasif.



RD-S4319V19

Kit de limpieza y accesorios Skin  
Cleaning kit and accessories

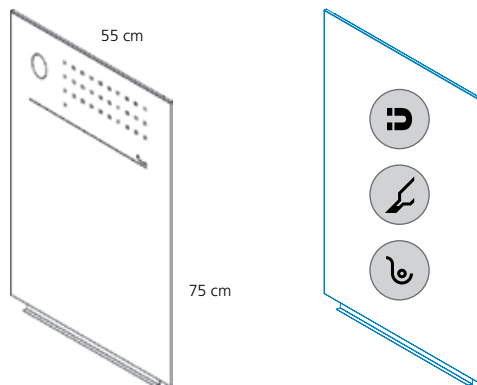

Lacada para rotulador / Lacquered for marker / Für Boardmarkeranwendungen beschichtet / Surface laqué pour des feutres effaçables.

Ref.	cm (embalaje / packaging)	kg / m <sup>3</sup> (embalaje / packaging)
RD-6419CL (55 x 75 cm)	84x64x3	4,5 kg / 0,017 m <sup>3</sup>

Para otras medidas y acabados consultar a Rocada / For other sizes and finishes consult Rocada

# SkinSUPPORT

## Soporte móvil de doble cara para Skin

Double sided mobile support for Skin · Mobiles, beidseitig bestückbares Tafelstativ für Skin Whiteboard  
Support mobile double face pour Skin

**[ESP]** Resistente soporte de metal con un diseño simple para Skin**WHITEBOARD** 100x150 cm (permite Skin en todos sus acabados). Sistema de fijaciones mediante imanes según el sistema patentado Skin. El soporte permite fijar 1 unidad Skin a cada lado dando lugar a una pizarra de dos caras. No incluye la pizarra.

**[ENG]** Sturdy metal mobile support with simple design for Skin**WHITEBOARD** 100x150cm (allows all Skin finishes). Fixing system through magnets following the Skin patented system. The support allows fixing 1 unit of Skin to each side, achieving double side boards. Skin board not included.

**[DE]** Mit dem Skin Tafelstativ lassen sich Skin Whiteboards auch mobil einsetzen. Dabei führt die Gestellkonstruktion das puristisch-elegante Design der Tafelmodule fort. Das Montageprinzip bleibt unverändert, die Anbringung erfolgt mittels starker Haftmagnete; diese sind im Lieferumfang des Stativs enthalten. Das Stativ kann ein- oder beidseitig bestückt werden, die gewünschten Tafelmodule ( nur 100x150cm) sind separat zu bestellen. Mit der Flipchartpapierklemme als Zusatzausstattung lässt sich der Anwendungsbereich erweitern. Dank des modularen Charakters können Sie sich ein mobiles und preiswertes Multifunktionsmöbel zusammenstellen, z.B.: Seite A : Skin Whiteboard Pro 6521 plus Flipcharthalterung RD 6430, Seite B Skin Projektionsboard RD 6421Matt. Also Whiteboard, Flipchart und Projektionstafel in einem. Und das Dank großer, feststellbarer Laufrollen mobil!

**[FR]** Support mobile en métal robuste avec un design simple compatible avec le Skin**WHITEBOARD** 100x150cm. Système de fixation simple grâce à des aimants qui suivent notre système breveté. Le support permet de fixer 2 tableaux (dos à dos). Tableaux non inclus.





El soporte no es compatible con la Skin Ceramic y Skin Shape  
The support doesn't allow installation of the Skin Ceramic and Skin Shape

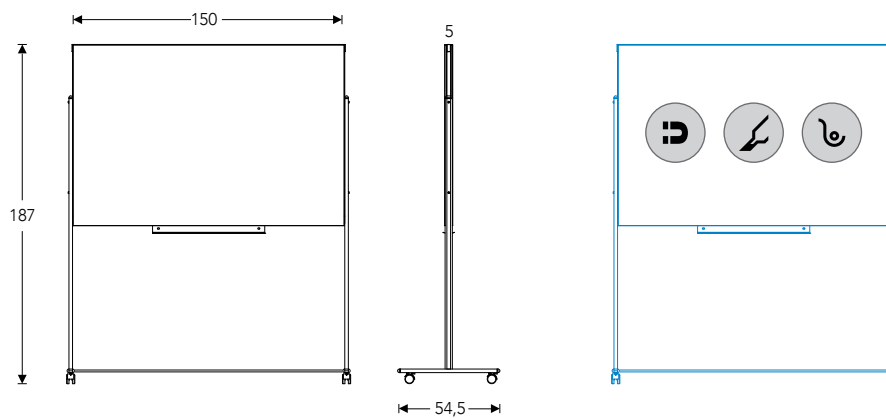

Skinwhiteboard, unlimited whiteboard



**RD-6430R**  
Accesorio bloque de papel / Paper block accessory  
20 hojas de 70gr / 20 sheets of 70gr

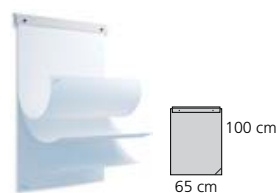

Ref.	cm (embalaje / packaging)	kg / m <sup>3</sup> (embalaje / packaging)
<b>RD-6875 (150 x 100 cm)</b> (solo soporte / only support)	159x100x7	17,10 kg / 0,111 m <sup>3</sup>
<b>RD-6430R (65x90cm)</b>	87x8x8	1,6 kg / 0,005 m <sup>3</sup>

Para otras medidas y acabados consultar a Rocada / For other sizes and finishes consult Rocada





Skinwhiteboard, unlimited whiteboard



Skin no incluida, solo protector  
Skin not included, only protector

▲  
¿Cómo se monta?  
How is it set up?  
Wie erfolgt die Montage?  
Comment l'installer ?

Medidas / Sizes (cm)

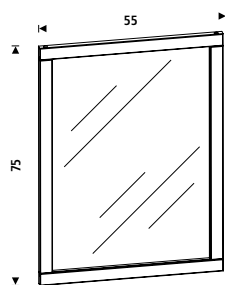

Marco madera 3.8x1.9cm  
Wood frame with magnetic system  
(3.8x1.9cm)  
Metacrilato 4mm de espesor  
Methacrylate of 4mm thickness

Ref.	cm (embalaje / packaging)	kg / m <sup>3</sup> (embalaje / packaging)
<b>RD-6419PRT (55x75cm) (4xA4)</b>	84x64x3	3,60 kg / 0.016 m <sup>3</sup>

Para otras medidas y acabados consultar a Rocada / For other sizes and finishes consult Rocada

# SkinBLOCK

**[ESP]** SkinBLOCK es el accesorio perfecto que se adapta a cualquier producto del Skin program. Incluye sistema de fijación y bloque de papel de 20 hojas de 70gr. Su fácil aplicación y fácil recambio agiliza la comunicación en todo momento.

**[ENG]** SkinBLOCK is the perfect accessory that adapts to any product of the Skin program. Includes fixing system and block of paper of 20 sheets of 70gr. Its easy application and easy replacement facilitate communication at all times.

**[DE]** SkinBLOCK ist das ideale Zubehör, das sich an jedes Produkt vom Skin Program anpasst. Einschließlich Befestigungssystem und Papierblock mit 20 Blättern und 70 Gramm Gewicht. Seine einfache Anwendung und der problemlose Austausch erleichtern die Kommunikation

**[FR]** SkinBLOCK est l'accessoire idéal qui s'adapte à n'importe quel produit du Skin program. Il inclut un système de fixation et un bloc de papier de 20 feuilles de 70 g. Application facile, simplicité de remplacement : il optimise la communication à tout moment.



Skinwhiteboard, unlimited whiteboard



No apto para **Skin Ceramic** ni **Skin Shape**  
 Not suitable for **Skin Ceramic** nor **Skin Shape**

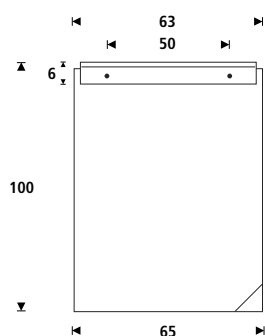

Ref.	cm (embalaje / packaging)	kg / m <sup>3</sup> (embalaje / packaging)
<b>RD-6430R</b> (65x90cm)	87x8x8	1,6 kg / 0,005 m <sup>3</sup>

Para otras medidas y acabados consultar a Rocada / For other sizes and finishes consult Rocada

Skinwhiteboard, unlimited whiteboard

# SkinnyNOTES

**[ESP]** Notas informativas removibles sin adhesivo. Permite la escritura en ambas caras con todo tipo de rotulador. 400 hojas, 100 hojas por color.

**[ENG]** Removable non-adhesive informative notes. Allows writing on both sides with any kind of marker. 400 sheets, 100 sheets per colour

**[DE]** Entfernbare Info-Notizen ohne Klebstoff. Ermöglicht das beidseitige Beschreiben mit jeglicher Art von Stift oder Marker. 400 Blätter, 100 Blätter pro Farbe

**[FR]** Notes d'information amovibles sans adhésif. Il est possible d'écrire sur les deux faces avec tout type de marqueur. 400 feuilles, 100 feuilles par couleur

NEW

Skinwhiteboard, unlimited whiteboard

Notas con carga estática  
Glue-free static notes







**RD-S4323MX**  
(20x10cm)  
Pack 4u

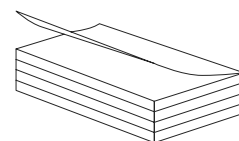

**RD-S4324MX**  
(12,5x12,5cm)  
Pack 4u

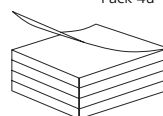

Parte trasera admite utilizar rotulador de borrado en seco  
Dry erase markers allows to be used on the backside

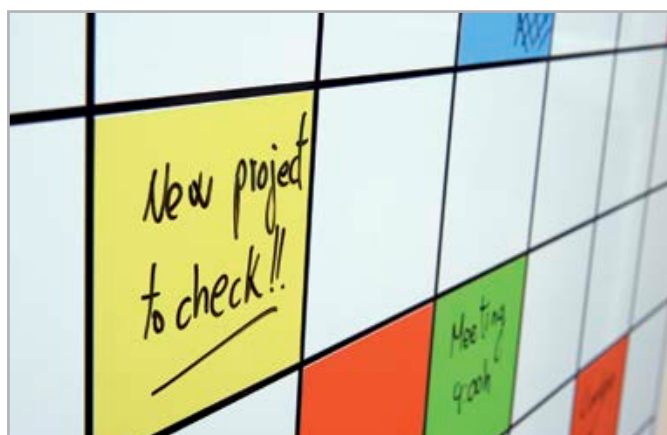

Ref.	Medidas / size	cm (embalaje / packaging)	kg / m <sup>3</sup> (embalaje / packaging)	Hojas / sheets
<b>RD-S4323MX</b> (20x10cm)	20x10 cm	20x10x3	0,30 kg / 0,001 m <sup>3</sup>	400 (100 / color)
<b>RD-S4324MX</b> (12,5x12,5cm)	12,5x12,5 cm	12,5x12,5x3	0,20 kg / 0,001 m <sup>3</sup>	400 (100 / color)

# SkinMAP

(Pizarra modular / Modular whiteboard)

**[ESP]** La SkinMAP es una pizarra especialmente preparada para ilustrar y trabajar entorno a los mapas. Dispone de una área generosa para todo tipo de anotaciones, fijación de imanes y otros accesorios magnéticos. El acabado de la zona de trabajo es totalmente compatible con los rotuladores de borrado en seco.

**[ENG]** The SkinMAP is a whiteboard specifically prepared to illustrate and work around maps. It has a generous area for all types of annotations, fixing magnets and other magnetic accessories. The whiteboard is fully compatible with dry erase markers.

**[DE]** SkinMAP ist eine Tafel, die speziell für die Illustration und die Arbeit in Verbindung mit Stadtplänen und Landkarten vorgesehen ist. Verfügt über einen umfangreichen Bereich für Anmerkungen, für die Anbringung von Magneten und von sonstigen magnetischen Zubehörteilen. Die Oberflächenausführung des Arbeitsbereichs ist für trocken abwischbare Boardmarker geeignet.

**[FR]** La SkinMAP est un tableau spécialement conçu pour l'illustration et le travail sur des plans. Il possède une zone généreuse pour tout type de notes, fixation aimantée et autres accessoires magnétiques. La finition de la zone de travail est entièrement compatible avec les marqueurs effaçables à sec.

NEW

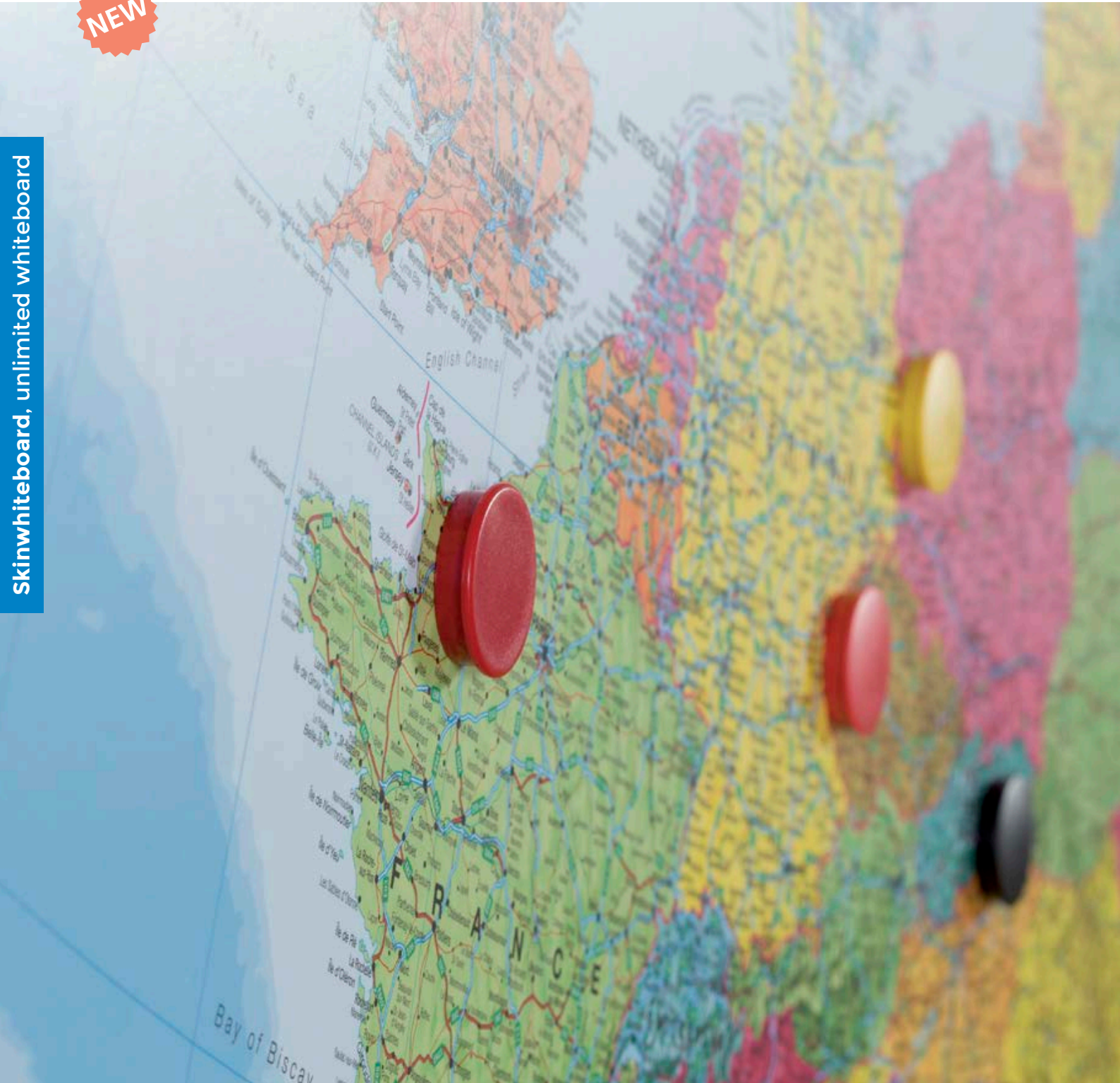

Skinwhiteboard, unlimited whiteboard



**6421MAPWD**  
 Texto en inglés / Text in English



**6421MAPUE**  
 Texto en inglés / Text in English



**6421MAPSP**  
 Texto en español / Text in Spanish

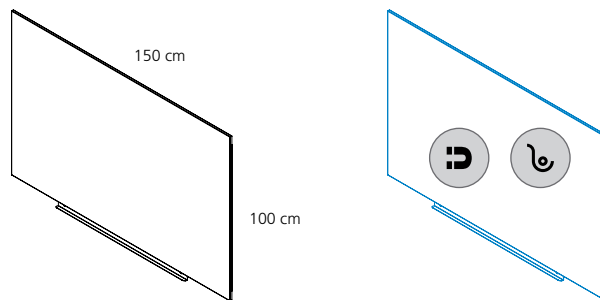

Ref.	cm (embalaje / packaging)	kg / m <sup>3</sup> (embalaje / packaging)
<b>6421MAPWD</b> World (150 x 100 cm)	159x109x3	16,10 kg / 0,052 m <sup>3</sup>
<b>6421MAPUE</b> Europe (150 x 100 cm)	159x109x3	16,10 kg / 0,052 m <sup>3</sup>
<b>6421MAPSP</b> Spain (150 x 100 cm)	159x109x3	16,10 kg / 0,052 m <sup>3</sup>

# PIZARRAS DE PARED

WHITEBOARDS • WANDSCHREIBTAFELN • TABLEAUX MURAUX

**[ESP]** Pizarra metálica y magnética (\*) con marco de aluminio anodizado. Superficie blanca apta para escritura con rotuladores de borrado en seco. Incluye bandeja para rotuladores y accesorios para la fijación a pared. Viene montada.

**[ENG]** Board with anodised aluminium frame with suitable surface for writing with dry-wipe markers. Includes marker tray and wall fixing accessories. Supplied assembled.

**[DE]** Standard - Whiteboard-Serie. Alurahmen mit grauem Eckverbinder. Ablageleiste und Montagematerial im Lieferumfang enthalten.

**[FR]** Tableau avec cadre en aluminium anodisé et surface pour écriture au marqueur effaçable à sec. Livré avec auget porte-marqueurs et kit de fixation murale. Livré monté.



Superficie para rotuladores de borrado en seco.  
No limpiar con alcohol o productos abrasivos.

Dry wipe surface. Never clean it with alcohol or abrasive products.

Bitte niemals mit reinem Alkohol reinigen und keine Tücher mit abrasiven Eigenschaften verwenden.

Surface effaçable à sec. Ne nettoyer jamais la surface avec de l'alcool ou un produit abrasif.





Compatible con soportes móviles RD-6870PLUS, RD-8090, RD-6870 y RD-6877  
Compatible with mobile supports RD-6870PLUS, RD-8090, RD-6870 and RD-6877



RD-S4319V19

Kit de limpieza y accesorios Skin  
Cleaning kit and accessories

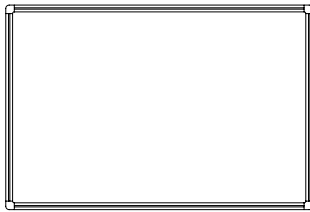

45 / 60 / 90 /  
100 / 120 cm

60/90/120/150/180/200/240 cm

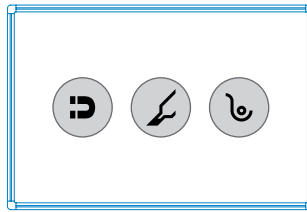

Pizarras vitrificadas  
Enamelled boards  
Emailliert Tafeln  
Tableaux vitrifié

**\*Vitrificada / enamelled / emailliert / vitrifié**

**Recomendada para uso diario / recommended for daily use**

Ref.	cm (embalaje / packaging)	kg / m <sup>3</sup> (embalaje / packaging)
RD-6500 (60x45 cm)	72x47x3	2,45 kg / 0,007 m <sup>3</sup>
RD-6502 (90x60 cm)	103x62x3	4,60 kg / 0,016 m <sup>3</sup>
RD-6504 (120x90 cm)	133x92x3	8,81 kg / 0,031 m <sup>3</sup>
RD-6507 (150x120 cm)	165x126x3	14,33 kg / 0,052 m <sup>3</sup>
RD-6508 (180x120 cm)	200x126x3	17,05 kg / 0,063 m <sup>3</sup>
RD-6511 (200x120 cm)	220x126x3	16,40 kg / 0,069 m <sup>3</sup>
RD-6512 (240x120 cm)	259x126x3	22,47 kg / 0,082 m <sup>3</sup>

**Para otras medidas consultar Skin Program / For other sizes consult Skin Program**

**\*Lacada / lacquered / lackiert / laqué**

**Recomendada para uso frecuente / recommended for common use**

Ref.	cm (embalaje / packaging)	kg / m <sup>3</sup> (embalaje / packaging)
RD-6400 (60x45 cm)	72x47x3	2,10 kg / 0,008 m <sup>3</sup>
RD-6402 (90x60 cm)	103x62x3	3,91 kg / 0,016 m <sup>3</sup>
RD-6404 (120x90 cm)	133x92x3	7,44 kg / 0,031 m <sup>3</sup>
RD-6406 (150x100 cm)	165x106x3	11,50 kg / 0,043 m <sup>3</sup>
RD-6407 (150x120 cm)	165x126x3	12,05 kg / 0,052 m <sup>3</sup>
RD-6408 (180x120 cm)	200x126x3	14,30 kg / 0,063 m <sup>3</sup>
RD-6410 (200x100 cm)	220x105x3	13,28 kg / 0,058 m <sup>3</sup>
RD-6411 (200x120 cm)	220x126x3	14,30 kg / 0,069 m <sup>3</sup>
RD-6412 (240x120 cm)	259x126x3	18,82 kg / 0,082 m <sup>3</sup>

**Para otras medidas consultar Skin Program / For other sizes consult Skin Program**

**Melamina / melamine / melamine / melaminé**

**Recomendada para uso normal / recommended for normal use**

Ref.	cm (embalaje / packaging)	kg / m <sup>3</sup> (embalaje / packaging)
RD-6300 (60x45 cm)	72x47x3	2,48 kg / 0,007 m <sup>3</sup>
RD-6302 (90x60 cm)	103x62x3	4,67 kg / 0,016 m <sup>3</sup>
RD-6304 (120x90 cm)	133x92x3	8,95 kg / 0,306 m <sup>3</sup>
RD-6308 (180x120 cm)	200x126x3	17,33 kg / 0,063 m <sup>3</sup>
RD-6311 (200x120 cm)	220x126x3	16,90 kg / 0,069 m <sup>3</sup>
RD-6312 (240x120 cm)	259x126x3	22,30 kg / 0,082 m <sup>3</sup>

# PIZARRA VITRIFICADA MATE

MATT ENAMELLED BOARD • MATT-EMAILLIERTE SCHREIBTAFEL  
TABLEAU VITRIFIÉ MAT

**[ESP]** Pizarra vitrificada metálica y magnética con marco de aluminio anodizado. Superficie apta para la escritura con rotuladores de borrado en seco. El acabado mate de la superficie está especialmente pensado para proyecciones audiovisuales e interactivas. Incluye bandeja para rotuladores y accesorios para la fijación a pared. Viene montada.

**[ENG]** Enamelled whiteboard with anodised aluminium frame with surface suitable for writing with dry-wipe markers. Includes marker tray and wall fixing accessories. The matt finish of the surface is designed especially for projection of audiovisuals, interactives, etc. Supplied assembled

**[DE]** Emaillierte Wandtafel mit matter Oberfläche, speziell für die Zweit-Verwendung als Projektionsfläche konzipiert. Rahmen aus eloxiertem Aluminium. Inklusive Markerablage und Zubehör für die Wandmontage. Zum Beschreiben mit trocken abwischbaren Boardmarkern geeignet.

**[FR]** Tableau mural vitrifié avec cadre en aluminium anodisé et surface apte pour l'écriture au marqueur effaçable à sec. Livré avec auget porte-marqueurs et kit pour fixation murale. La finition mate de la surface est spécialement conçue pour la projection d'audio-visuels, interactifs, ... Livré monté.

años de garantía  
**25**  
years guarantee

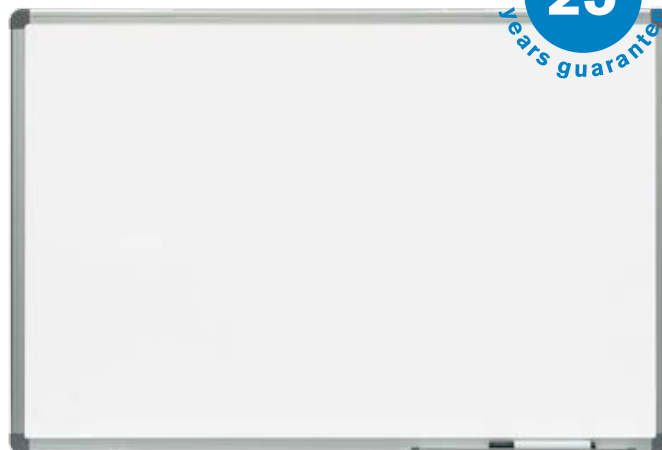

RD-S4040MX\*12

Rotuladores  
Board markers  
Tafelschreiber  
Marqueurs



Superficie para rotuladores de borrado en seco.  
No limpiar con alcohol o productos abrasivos.  
Dry wipe surface. Never clean it with alcohol or abrasive products.  
Bitte niemals mit reinem Alkohol reinigen und keine Tücher mit abrasiven Eigenschaften verwenden.  
Surface effaçable à sec. Ne nettoyer jamais la surface avec de l'alcool ou un produit abrasif.



100/150/200/240 cm

120 cm

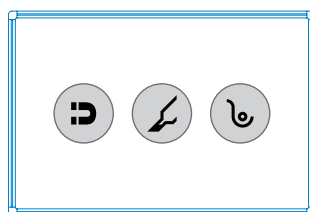

Compatible con soportes móviles RD-6870PLUS, RD-8090, RD-6870 y RD-6877  
Compatible with mobile supports RD-6870PLUS, RD-8090, RD-6870 and RD-6877

Vitrificada / enamelled / emailliert / vitrifié

Recomendada para uso diario / recommended for daily use

Ref.	cm (embalaje / packaging)	kg / m <sup>3</sup> (embalaje / packaging)
RD-6505MAT (100x120)	126x120x3	11,50 / 0,038 m <sup>3</sup>
RD-6507MAT (150x120)	165x126x3	14,33 / 0,052 m <sup>3</sup>
RD-6511MAT (200x120)	220x126x3	16,40 / 0,069 m <sup>3</sup>
RD-6512MAT (240x120)	259x126x3	22,40 / 0,082 m <sup>3</sup>

Para otras medidas consultar Skin Program / For other sizes consult Skin Program

# PIZARRA DOBLE CARA

DOUBLE-SIDED BOARD • DOPPELSEITIGE TAFEL • TABLEAU À DOUBLE FACE

**[ESP]** Pizarra de doble cara metálica y magnética con marco de aluminio anodizado. Superficie blanca apta para escritura con rotuladores de borrado en seco. Viene montada.

**[ENG]** Double-sided board with anodised aluminium frame with surface suitable for writing with dry-wipe markers. Supplied assembled.

**[DE]** Doppelseitige Tafel mit Rahmen aus eloxiertem Aluminium. Zum Beschreiben mit trocken abwischbaren Markern. Wird montiert geliefert.

**[FR]** Tableau à double face avec cadre en aluminium anodisé et surface apte pour l'écriture au marqueur effaçable à sec. Livré monté.

Sólo para superficie vitrificada  
Only for enamelled surface

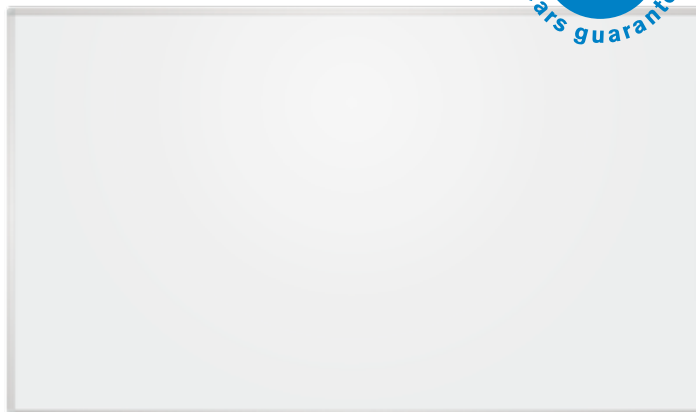

Superficie para rotuladores de borrado en seco.  
No limpiar con alcohol o productos abrasivos.  
Dry wipe surface. Never clean it with alcohol or abrasive products.  
Bitte niemals mit reinem Alkohol reinigen und keine Tücher mit abrasiven Eigenschaften verwenden.  
Surface effaçable à sec. Ne nettoyer jamais la surface avec de l'alcool ou un produit abrasif.



120/150/180/200 cm

90/120 cm

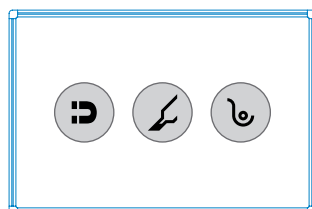

Compatible con soportes móviles RD-6870PLUS, RD-8090, RD-6870 y RD-6877  
Compatible with mobile supports RD-6870PLUS, RD-8090, RD-6870 and RD-6877

## Vitrificada / enamelled / emailiert / vitrifié

## Recomendada para uso diario / recommended for daily use

Ref.	cm (embalaje / packaging)	kg / m <sup>3</sup> (embalaje / packaging)
RD-6854 (120x90 cm)	133x95x3	12,40 kg / 0,030 m <sup>3</sup>
RD-6855 (150x120 cm)	165x126x3	17,30 kg / 0,052 m <sup>3</sup>
RD-6856 (180x120 cm)	200x126x3	20,25 kg / 0,063 m <sup>3</sup>
RD-6857 (200x120 cm)	220x126x3	22,50 kg / 0,069 m <sup>3</sup>

## Lacada / lacquered / lackiert / laqué

## Recomendada para uso frecuente / recommended for common use

Ref.	cm (embalaje / packaging)	kg / m <sup>3</sup> (embalaje / packaging)
RD-6950 (120x90 cm)	133x95x3	11,50 kg / 0,030 m <sup>3</sup>
RD-6951 (150x120 cm)	165x126x3	16,30 kg / 0,052 m <sup>3</sup>
RD-6952 (180x 120 cm)	200x126x3	18,30 kg / 0,063 m <sup>3</sup>
RD-6953 (200x120 cm)	220x126x3	20,34 kg / 0,069 m <sup>3</sup>

# PIZARRA PARED CRISTAL

GLASS WHITEBOARDS • GLAS-SCHREIBTAFEL • TABLEAU EN VERRE

**[ESP]** Pizarra de pared de cristal templado de 6 mm. Perfecta escritura y borrado gracias a su tratamiento superficial. Incorpora bandeja metálica. Viene montada.

**[ENG]** Tempered glass 6mm glassboard, with perfect writing and cleaning characteristics thanks to its finished treatment. Includes metal tray for board markers. Comes mounted.

**[DE]** Schreibtafel aus satiniertem, gehärtetem Glas, 6mm. Perfekte Schreib- und Reinigungseigenschaften aufgrund der geschlossenen Oberfläche. Inkl: Ablageleiste für Boardmarker.

**[FR]** Tableau en verre trempé de 6 mm. Écriture et effaçage parfaits grâce à son traitement en surface. Comprend un plateau métallique. Livré monté.

Sólo superficie  
Only surface

años de garantía  
**25**  
years guarantee



Cristal pintado blanco  
White painted glass

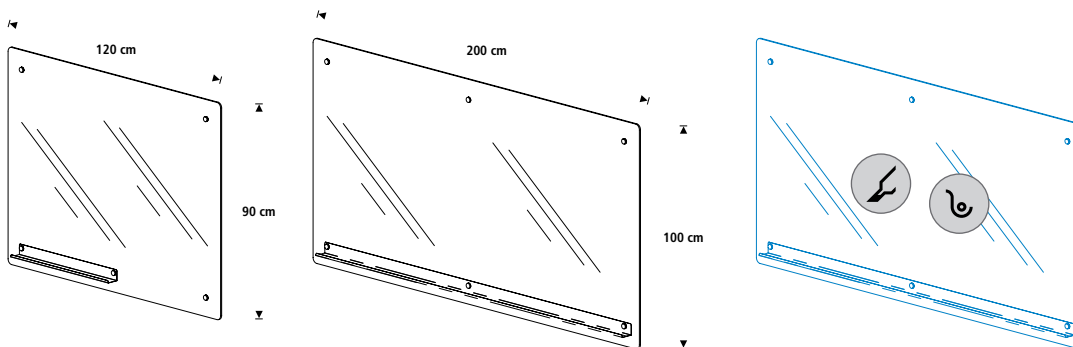

Incluye un rotulador  
Marker included

Recomendada para uso diario / recommended for daily use

Ref.	cm (embalaje / packaging)	kg / m <sup>3</sup> (embalaje / packaging)
<b>RD-6700</b> (120x90 cm)	125x95x6	15 kg / 0,071 m <sup>3</sup>
<b>RD-6701</b> (200x100 cm)	210x105x6	22 kg / 0,132 m <sup>3</sup>



# PIZARRA VITRIFICADA VERDE

GREEN ENAMELLED BOARD • EMAILLIERTE KREIDETAFEL • TABLEAU VITRIFIÉ VERT

**[ESP]** Pizarra vitrificada metálica y magnética de superficie color verde apta para escritura con rotuladores de tiza líquida o tiza. Marco de aluminio anodizado. Incluye bandeja para útiles de escritura y accesorios para la fijación a pared. Viene montada.

**[ENG]** Magnetic enamelled board with a green surface suitable for writing with liquid chalk markers and chalk, with anodised aluminium frame. Includes writing tool tray and wall fixing accessories. Supplied assembled.

**[DE]** Emaillierte Schreibtafel mit grüner, magnethaftender Oberfläche zum Beschreiben mit Kreide. Rahmen aus eloxiertem Aluminium. Inklusive Schreibgeräteablage und Zubehör für die Wandmontage. Für intensive Anwendungen geeignet.

**[FR]** Tableau vitrifié magnétique avec surface de couleur verte apte pour craie avec cadre en aluminium anodisé. Livré avec auget porte-accessoires d'écriture et kit pour fixation murale. Livré monté.

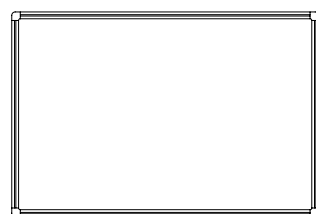

90/120 cm

120/150/180/200 cm

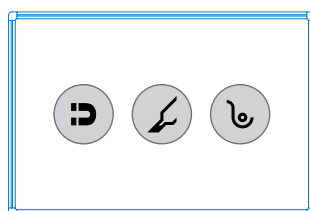

Compatible con soportes móviles RD-6870PLUS, RD-8090, RD-6870 y RD-6877  
Compatible with mobile supports RD-6870PLUS, RD-8090, RD-6870 and RD-6877

Vitrificada / enamelled / emailliert / vitrifié

Recomendada para uso diario / recommended for daily use

Ref.	cm (embalaje / packaging)	kg / m <sup>3</sup> (embalaje / packaging)
RD-6507GRCH (150x120 cm)	165x126x3	14,30 / 0,052 m <sup>3</sup>
RD-6508GRCH (180x120 cm)	200x94x3	17,00 / 0,063 m <sup>3</sup>
RD-6511GRCH (200x120 cm)	200x126x3	20,50 / 0,069 m <sup>3</sup>
RD-6512GRCH (240x120 cm)	260x126x3	22,50 / 0,082 m <sup>3</sup>

# PIZARRAS DE CORCHO

CORKBOARDS • KORKTAFELN • TABLEAUX EN LIÈGE

**[ESP]** Tablero de corcho con marco de aluminio anodizado. Corcho resistente y autorregenerable. Incluye accesorios para la fijación a la pared. Viene montado.

**[ENG]** Corkboard with anodised aluminium frame. Includes accessories for wall fixing. Comes assembled.

**[DE]** Korktafel mit Rahmen aus eloxiertem Aluminium. Inklusive Zubehör für die Wandmontage.

**[FR]** Tableau en liège avec cadre en aluminium anodisé. Livré avec kit pour fixation murale. Livré monté.

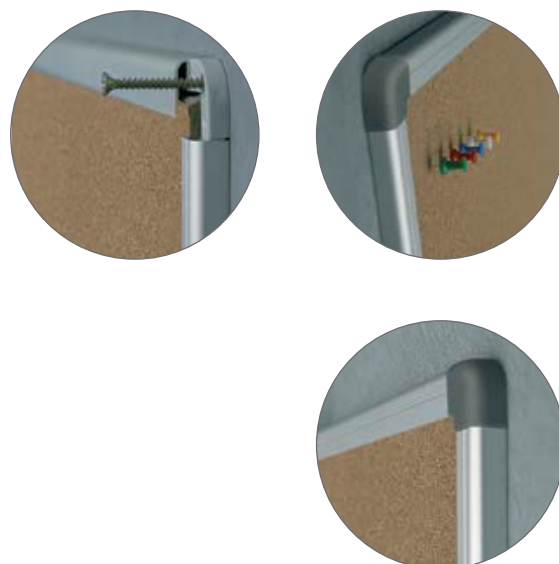

Compatible con soportes móviles RD-6870PLUS, RD-8090, RD-6870 y RD-6877  
Compatible with mobile supports RD-6870PLUS, RD-8090, RD-6870 and RD-6877



45/60/90/100/120 cm

60/90/120/150/180/240 cm

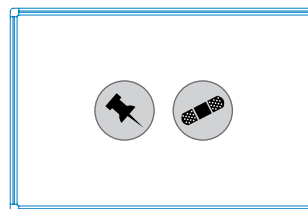

Ref.	cm (embalaje / packaging)	kg / m <sup>3</sup> (embalaje / packaging)
RD-6200 (60x45 cm)	72x47x3	1,40 kg / 0,007 m <sup>3</sup>
RD-6202 (90x60 cm)	103x62x3	2,77 kg / 0,016 m <sup>3</sup>
RD-6204 (120x90 cm)	133x92x3	5,40 kg / 0,031 m <sup>3</sup>
RD-6206 (150x100 cm)	165x105x3	7,72 kg / 0,043 m <sup>3</sup>
RD-6208 (180x120 cm)	200x126x3	10,85 kg / 0,063 m <sup>3</sup>
RD-6212 (240x120 cm )	259x126x3	14,21 kg / 0,082 m <sup>3</sup>

# TABLERO TAPIZADO

UPHOLSTERED BOARD • STOFF-PINNTAFEL • PANNEAU TAPISSÉ

**[ESP]** Tablero tapizado con marco de aluminio anodizado. Suave superficie de fieltro. Incluye accesorios para la fijación a la pared.

**[ENG]** Upholstered board with anodised aluminium frame. Includes accessories for wall fixing.

**[DE]** Stoff-Pinntafel. Rahmen aus eloxiertem Aluminium. Inklusive Zubehör für die Wandmontage.

**[FR]** Panneau tapissé avec cadre en aluminium anodisé. Livré avec kit pour fixation murale.

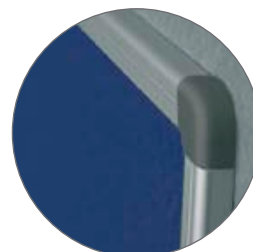

Compatible con soportes móviles RD-6870PLUS, RD-8090, RD-6870 y RD-6877  
Compatible with mobile supports RD-6870PLUS, RD-8090, RD-6870 and RD-6877

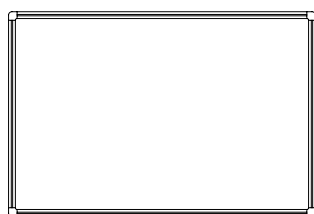

45/60/90/120 cm

60/90/120/180 cm

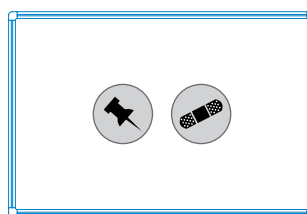

Ref.	cm (embalaje / packaging)	kg / m <sup>3</sup> (embalaje / packaging)
<b>RD-6600</b> (60x45 cm)	72x47x3	1,60 kg / 0,007 m <sup>3</sup>
<b>RD-6602</b> (90x60 cm)	103x62x3	2,90 kg / 0,016 m <sup>3</sup>
<b>RD-6604</b> (120x90 cm)	133x92x3	5,40 kg / 0,031 m <sup>3</sup>
<b>RD-6608</b> (180x120 cm)	200x126x3	10,85 kg / 0,063 m <sup>3</sup>

Para otras medidas consultar Skin Program / For other sizes consult Skin Program

# PIZARRA TRÍPTICA VITRIFICADA

TRIPTIC ENAMELLED WHITEBOARD • KLAPPTAFEL  
TABLEAU TRIPTYQUE EN VITRIFIÉ

**[ESP]** Pizarra metálica y magnética tríptica con marco de aluminio anodizado. Superficie blanca vitrificada apta para escritura con rotuladores de borrado en seco. 5 paneles para la escritura. Incluye bandeja para rotuladores y accesorios para la fijación a pared. Viene montada.

**[ENG]** Triptic enamelled whiteboard of anodized aluminium, 5 writing surfaces. Comes mounted.

**[DE]** Dreigeteiltes, emalliertes Whiteboard aus anodisiertem Aluminium, 5 Schreib-Oberflächen. Vormontiert.

**[FR]** Tableau triptyque en vitrifié avec cadre aluminium anodisé et 5 panneaux pour l'écriture. Livré monté.

Sólo superficie  
Only surface

**25**  
años de garantía  
years guarantee

**MEJORADA  
IMPROVED**

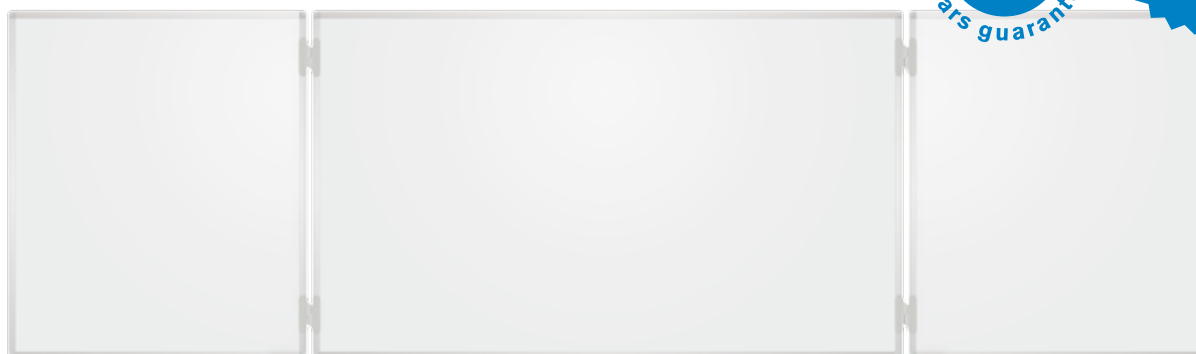

**RD-S4319V19**

Kit de limpieza y accesorios Skin  
Cleaning kit and accessories



Superficie para rotuladores de borrado en seco.

Dry wipe surface.

Bitte niemals mit reinem Alkohol reinigen und keine  
Tücher mit abrasiven Eigenschaften verwenden.

Surface effaçable à sec.

Medidas / Sizes (cm)

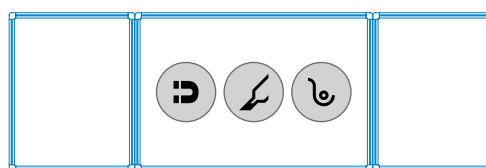
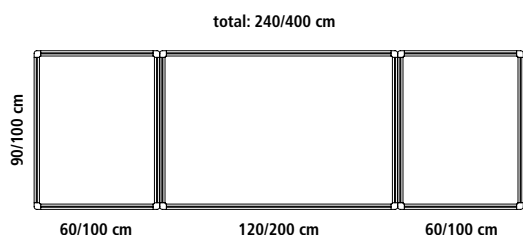

Vitrificada / enamelled / emailiert / vitrifié

Recomendada para uso diario / recommended for daily use

Ref.	cm (embalaje / packaging)	kg / m <sup>3</sup> (embalaje / packaging)
<b>RD-6728</b> (240x90 cm)	133x92x5	20,52 kg / 0,061 m <sup>3</sup>
<b>RD-6729</b> (400x100 cm)	220x105x5	36,84 kg / 0,115 m <sup>3</sup>

# GUÍA DE PIZARRAS

WHITEBOARD GUIDE • ANWEISUNGEN FÜR TAFELN • GUIDE DE TABLEAU

## SkinWhiteboard

Superficie Surface	Frecuencia de uso Use frequency (1 -10)	Resistencia a los arañazos Scratch Resistant	Magnético Magnetic	Garantía (años) warranty (years)	Alcohol	Limpieza Cleaning
Skin Colour	★★★★★ ☆☆☆☆☆	✗	✓	5	✗	Solo agua y regularmente Only water and regular cleaning
Skin Pro	★★★★★ ★★★★☆☆	✗	✓	15	✓	Agua o alcohol, limpieza puntual Water and alcohol, puntual cleaning
Skin Ceramic	★★★★★ ★★★★★	✓	✓	25	✓	Agua o alcohol, limpieza puntual Water and alcohol, puntual cleaning

## Otras · other

Superficie Surface	Frecuencia de uso Use frequency (1 -10)	Resistencia a los arañazos Scratch Resistant	Magnético Magnetic	Garantía (años) warranty (years)	Alcohol	Limpieza Cleaning
Melamina Melamine	☆☆☆☆☆ ☆☆☆☆☆	✗	✗	2	✗	Solo agua y regularmente Only water and regular cleaning
Lacada Lacquered	★★★★★ ☆☆☆☆☆	✗	✓	5	✗	Solo agua y regularmente Only water and regular cleaning
Cerámico - acero esmaltado Porcelain - enamel steel	★★★★★ ★★★★★	✓	✓	25	✓	Agua o alcohol, limpieza puntual Water and alcohol, puntual cleaning
Vidrio Glass	★★★★★ ★★★★★	✓	✗	25	✓	Agua o alcohol, limpieza puntual Water and alcohol, puntual cleaning

# SOPORTE MÓVIL

MOBILE SUPPORT • STATIVDREHTAFEL • PIÉTEMENT MOBILE

**[ESP]** Soporte móvil volteable ajustable en altura. Incorpora un nuevo sistema FREE ROTATION único en el mercado que permite un giro seguro de la pizarra al cambiar de cara y evita cualquier movimiento de balanceo al escribir. El nuevo sistema de regulación de altura permite una adaptación total a cada usuario facilitando la escritura y la visualización de la misma. Robusta estructura realizada en tubo de acero. Incorpora bandeja para útiles de escritura y ruedas con freno de diseño. Fácil montaje. Pizarra no incluida.

**[ENG]** Adjustable height and mobile stand. It incorporates a new FREE ROTATION system. Unique in the market that allows a safe turn of the board when changing faces and prevents any movement of rolling when writing. The new height adjustment system allows a total adaptation to each user facilitating the writing and visualization of it. Robust structure made of steel tube. It incorporates a tray for writing tools and wheels with a designed brake. Easy assembly, whiteboard not included.

**[DE]** Mobiles und höhenverstellbares Drehgestell. Es ist mit dem neuen System FREE ROTATION versehen, das marktweit einzigartig ist und ein sicheres Drehen der Tafel beim Seitenwechsel ermöglicht sowie jegliche Schwingbewegung beim Schreiben verhindert. Das neue System zur Höhenverstellung erlaubt die vollständige Anpassung an jeden Benutzer und erleichtert das Schreiben sowie das Lesen. Robustes Gestell aus Stahlrohr. Einschließlich Schreibablage und feststellbare Laufrollen. Einfache Montage. Tafel nicht inbegriffen.

**[FR]** Support mobile pivotant réglable en hauteur. Il intègre un nouveau système FREE ROTATION unique sur le marché qui garantit une rotation sûre du tableau pour changer de face et évite tout type de mouvement de balancier lors de l'écriture. Grâce au nouveau système de réglage de la hauteur, il sera toujours parfaitement adapté à chaque utilisateur et facilite aussi bien l'écriture que la visualisation. Structure robuste fabriquée en tube d'acier. Plateau utile pour les outils d'écriture et roues équipées de frein. Installation facile. Tableau non inclus.



NEW

Nuevo sistema Free rotation que permite una rotación sin necesidad de herramientas, de forma directa que facilita la comunicación.

New Free rotation system that allows a rotation without the need of tools, in a direct way that facilitates communication.

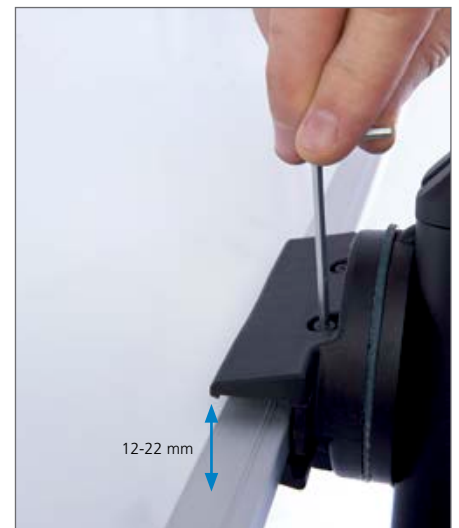

**NEW**



Nuevo sistema de anclaje que evita agujerear la pizarra.  
New anchoring system that avoids piercing the board.



Fácil regulación de altura · Easy height adjustment



Bandeja de gran formato · Large tray

Medidas / Sizes (cm)

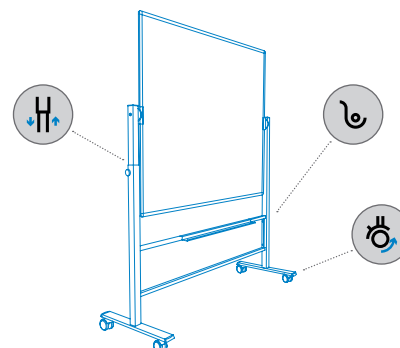
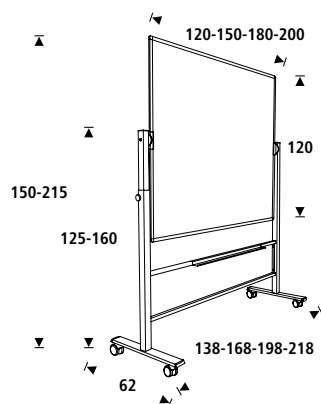

Ref.	cm (embalaje / packaging)	kg / m <sup>3</sup> (embalaje / packaging)
<b>RD-6870PLUS (120 cm)</b>	140x68x15	14,50 kg / 0,142 m <sup>3</sup>
<b>RD-6871PLUS (150 cm)</b>	170x68x15	17,00 kg / 0,173 m <sup>3</sup>
<b>RD-6872PLUS (180 cm)</b>	200x68x15	19,50 kg / 0,204 m <sup>3</sup>
<b>RD-6873PLUS (200 cm)</b>	220x68x15	22,00 kg / 0,224 m <sup>3</sup>

# SOPORTE MÓVIL

MOBILE SUPPORT • STATIVDREHTAFEL • PIÉTEMENT MOBILE

**[ESP]** Soporte móvil volteable de gran diseño. Incorpora un nuevo sistema FREE ROTATION único en el mercado que permite un giro seguro de la pizarra al cambiar de cara y evita cualquier movimiento de balanceo al escribir. Su nuevo diseño curvado permite su utilización en una posición más cómoda para el usuario. Incorpora bandeja para útiles de escritura y ruedas con freno de diseño. Fácil montaje. Pizarra no incluida.

**[ENG]** High-quality designed metal mobile support with 'FREE ROTATION' safety turning system allowing writing on both sides of the board. Its new design provides the most comfortable position for the user. Incorporates a tray for writing tools. Easy to assemble. Board not included.

**[DE]** Mobile Stativdrehtafel mit komfortabler Einhand-Fixierung. Der Neigungswinkel der Tafel kann abgestuft eingestellt werden. Die gekrümmte Gestell-Form ermöglicht zwei unterschiedliche Arbeitspositionen. Stabile, feststellbare Laufrollen. Das schwarz pulverbeschichtete Gestell ist in vier Größen erhältlich, die doppelseitige Tafel ist entsprechend separat zu bestellen.

**[FR]** Support mobile métallique très design avec système de rotation de sécurité FREE ROTATION permettant d'écrire sur les deux faces du tableau. Son nouveau design permet de l'utiliser dans la position la plus pratique pour l'utilisateur. Livré avec un auget porte-accessoires d'écriture. Facile à monter. Tableau non inclus.



Nuevo sistema Free rotation que permite una rotación sin necesidad de herramientas, de forma directa que facilita la comunicación.

New Free rotation system that allows a rotation without the need of tools, in a direct way that facilitates communication.





Nuevo sistema de anclaje que evita agujerear la pizarra.  
New anchoring system that avoids piercing the board.



Bandeja de gran formato · Large tray

Medidas / Sizes (cm)

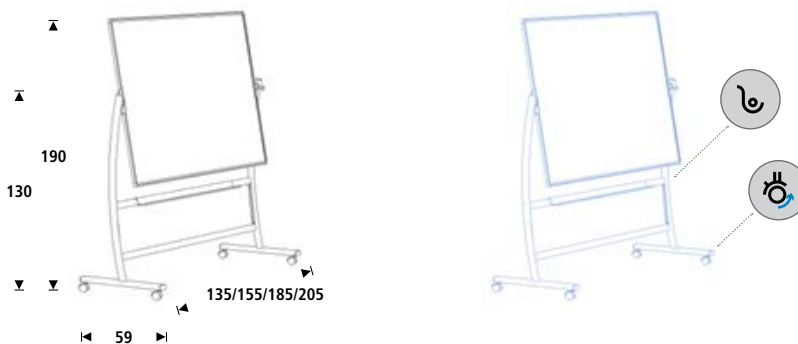

Ref.	cm (embalaje / packaging)	kg / m <sup>3</sup> (embalaje / packaging)
<b>RD-6870</b> (120 cm)	140x68x15	14,50 kg / 0,142 m <sup>3</sup>
<b>RD-6871</b> (150 cm)	170x68x15	17,00 kg / 0,173 m <sup>3</sup>
<b>RD-6872</b> (180 cm)	200x68x15	19,50 kg / 0,204 m <sup>3</sup>
<b>RD-6873</b> (200 cm)	220x68x15	22,00 kg / 0,224 m <sup>3</sup>
<b>RD-6871PK</b> Soporte + pizarra RD-6951 de 150cm Support + 150cm whiteboard RD-6951	171x127x14	33,40 kg / 0,293 m <sup>3</sup>

# SOPORTE TRÍPODE

TRIPOD SUPPORT • STATIV • SUPPORT TRÉPIEDS

**[ESP]** Soporte universal de pizarras de pared regulable en altura acabado en epoxy color gris. Viene montado.

**[ENG]** Universal height adjustable support for whiteboard. Powder coated in grey finish. Delivered assembled.

**[DE]** Universal-Stativ für Wandtafeln. Vormontiert.

**[FR]** Support universel pour tableaux. Livré monté.

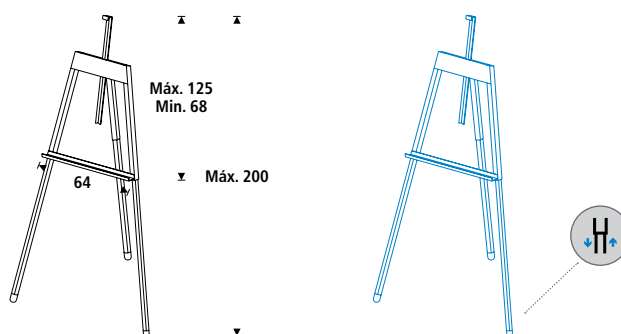
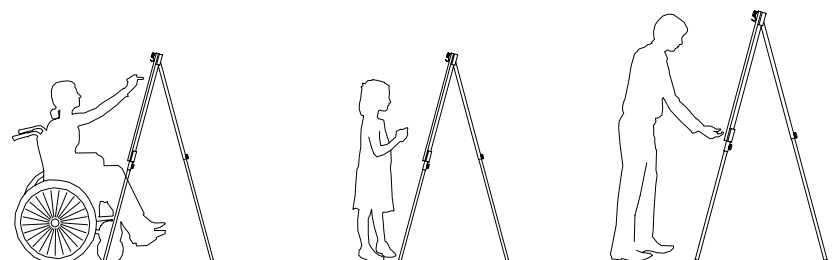

Ref.	cm (embalaje / packaging)	kg / m (embalaje / packaging)
RD-8090	117X67X10	8 kg / 0,078 m <sup>3</sup>

# SOPORTE MÓVIL UNIVERSAL

UNIVERSAL MOBILE SUPPORT • UNIVERSELLE MOBILE UNTERSTÜTZUNG  
SUPPORT MOBILE UNIVERSEL

**[ESP]** Soporte móvil universal de pizarras de pared que permite la fijación de pizarras de de 90cm, 100cm y 120cm de alto. Incorpora ruedas con freno. Opción con niveladores bajo pedido. Fácil montaje

**[ENG]** Universal mobile stand of whiteboards that allows to be fixed at 90cm, 100cm and 120cm wide. It includes wheels with brake system. An option with levelers on request. Easy to assemble.

**[DE]** Universelles, mobiles Gestell für whiteboards bis 2m, das bei einer Breite von 90cm, 100cm und 120cm fixiert werden kann. Es enthält Rollen mit Bremssystem. Auf Nachfrage mit Nivellierern erhältlich. Einfach aufzustellen.

**[FR]** Support de tableau mobile universel. Il permet la fixation des tableaux d'une largeur de 90 à 120 cm. Il comprend des roues avec un système de frein. (Si vous voulez un tableau avec des pieds pour qu'il reste fixe, vous pouvez en faire la demande).



Longitud pizarra max. 2m.  
Pizarra no incluida  
Whiteboard length max 2m.  
Board not included



Medidas / Sizes (cm)

Indicado para pizarras de 90, 100 y 120 cm de alto  
Suitable for 90, 100 and 120 high flipcharts

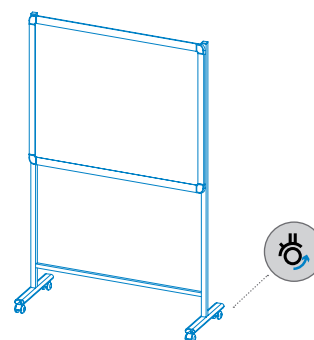
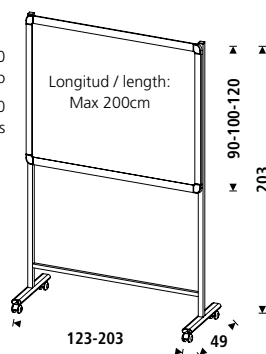

Ref.	cm (embalaje / packaging)	kg / m (embalaje / packaging)
RD-6877 (sólo soporte / only support)	190x6x6	9 kg / 0,006 m <sup>3</sup>

# PIZARRA

## BOARD • SCHREIBTAFEL • TABLEAU

**[ESP]** Pizarra con marco de pino. Superficie blanca apta para la escritura con rotuladores de borrado en seco. Incluye accesorios para la fijación a pared. Viene montada.

**[ENG]** Board with pine frame with surface suitable for writing with dry-wipe markers. Includes accessories for wall fixing. Comes assembled.

**[DE]** Schreibtafel mit Kieferholzrahmen. Zum Beschreiben mit trocken abwischbaren Markern. Inklusive Zubehör für die Wandmontage. Lieferung nur auf Anfrage.

**[FR]** Tableau avec cadre en pin et surface pour écriture au marqueur effaçable à sec Fourni avec kit pour fixation murale. Livré monté.

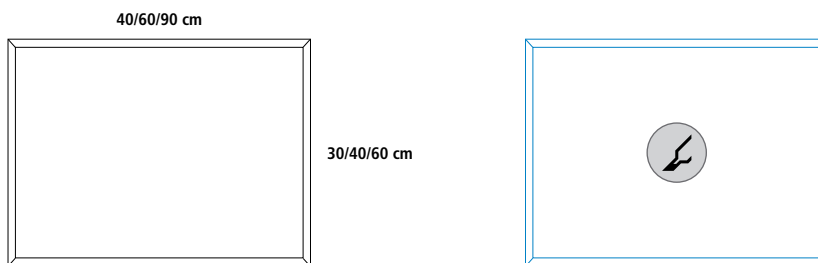

Melamina / melamine / melamine / melaminé

Recomendada para uso normal / recommended for normal use

Ref.	cm (embalaje / packaging)	kg / m <sup>3</sup> (embalaje / packaging)
<b>RD-6106V19</b> (40x30 cm) (10u.)	61x41x29	15,90 kg / 0,073 m <sup>3</sup>
<b>RD-6107V19</b> (60x40 cm) (10u.)	61x41x29	14,60 kg / 0,073 m <sup>3</sup>
<b>RD-6108V19</b> (90x60 cm) (5u.)	81x61x15	15,10 kg / 0,074 m <sup>3</sup>

# PIZARRA

BOARD • KOMBITAFEL • TABLEAU

**[ESP]** Pizarra combinada con superficie mitad en metal blanco para utilizar con rotuladores de borrado en seco y mitad en corcho autorregenerable. Construida con marco de pino. Incluye accesorios para la fijación a pared. Viene montada.

**[ENG]** Combined board with half-metal and half-cork surface and pine frame. Includes accessories for wall fixing. Comes assembled.

**[DE]** Kombination aus Schreib- und Pinn Tafel, zur einen Hälfte mit Metalloberfläche, zur anderen Hälfte mit Korkoberfläche. Mit Kieferholzrahmen. Inklusive Zubehör für die Wandmontage. Lieferung nur auf Anfrage.

**[FR]** Tableau combiné avec surface moitié metal, moitié liège et cadre en pin Fourni avec kit pour fixation murale. Livré monté.

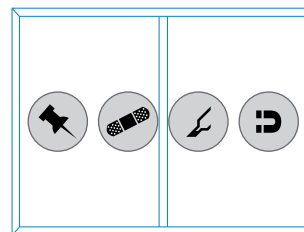
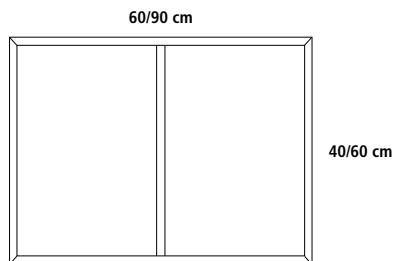

Ref.	cm (embalaje / packaging)	kg / m <sup>3</sup> (embalaje / packaging)
<b>RD-6120V19</b> (60x40 cm) (10u.)	61x41x30	16,00 kg / 0,075 m <sup>3</sup>
<b>RD-6121V19</b> (90x60 cm) (10u.)	91x61x16	15,50 kg / 0,089 m <sup>3</sup>

# PIZARRAS DE CORCHO

CORKBOARDS • KORKTAFELN • TABLEAUX EN LIÈGE

**[ESP]** Tablero de corcho con marco de pino. Incluye accesorios para la fijación a pared. Viene montada.

**[ENG]** Corkboard with pine frame. Includes accessories for wall fixing. Comes assembled.

**[DE]** Korktafel mit Kieferholzrahmen. Inklusive Zubehör für die Wandmontage. Lieferung nur auf Anfrage.

**[FR]** Tableau en liège et cadre en pin. Fourni avec kit pour fixation murale. Livré monté.

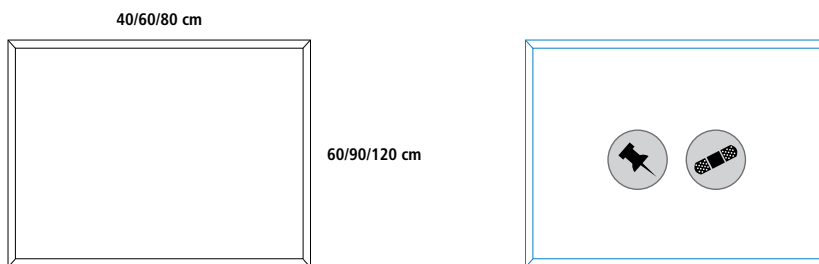
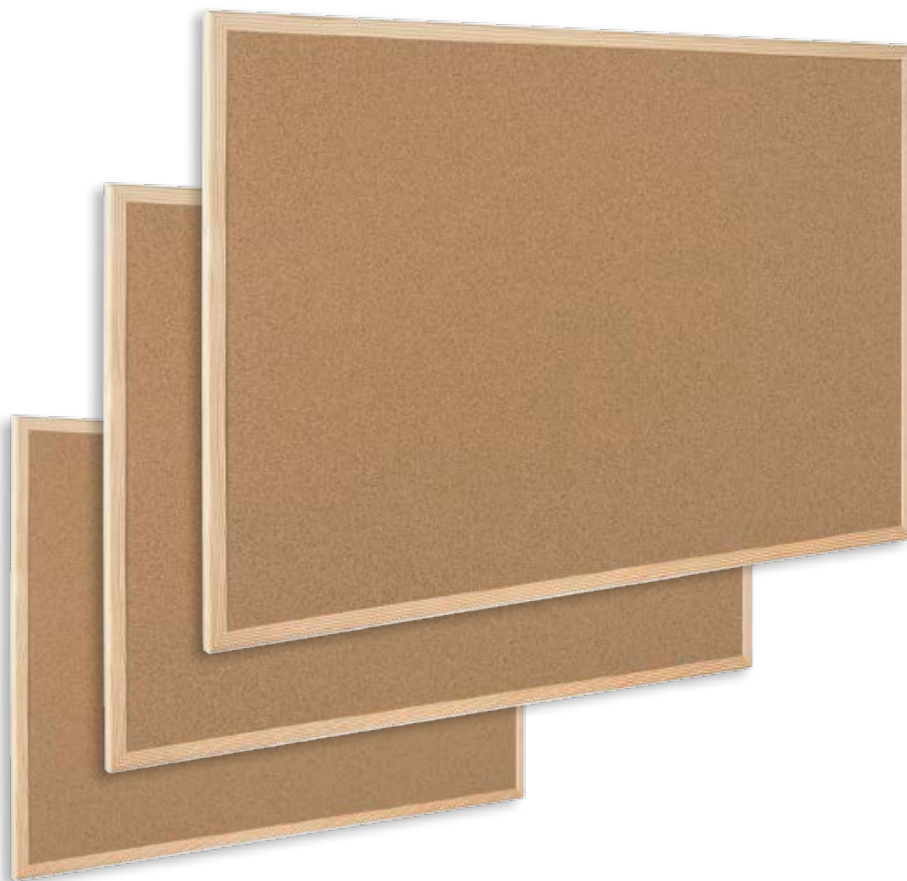

Ref.	cm (embalaje / packaging)	kg / m <sup>3</sup> (embalaje / packaging)
<b>RD-6100V19</b> (60x40 cm) (10u.)	61x41x30	11,00 kg / 0,081 m <sup>3</sup>
<b>RD-6102V19</b> (90x60 cm) (10u.)	91x61x15	11,00 kg / 0,083 m <sup>3</sup>
<b>RD-6103V19</b> (120x60 cm) (5u.)	121x61x10	10,00 kg / 0,073 m <sup>3</sup>
<b>RD-6111V19</b> (120x80 cm) (5u.)	121x81x10	17,00 kg / 0,098 m <sup>3</sup>

# ACCESORIOS PIZARRAS BLANCAS Y DE PARED

WHITEBOARD AND FLIPCHART ACCESSORIES • SCHREIBTAFEL-UND FLIPCHARTZUBEHÖR  
ACCESSOIRES POUR TABLEAUX BLANC

**[ESP]** Kit de limpieza y accesorios.

Incluye: 4 rotuladores de colores mezclados, 10 imanes de Ø30mm de colores mezclados, cubilete magnético para rotuladores, estuche con 25 toallitas de limpieza, unidad de recambio con otras 25 toallitas adicionales y borrador magnético de gran adherencia.

**[ENG]** Cleaning and accessory kit.

Includes: 4 different coloured marker pens, 10 different coloured Ø30mm magnets, magnetic cup for marker pens, case with 25 cleaning wipes, a replacement unit with another 25 wipes and magnetic eraser.

**[DE]** Das perfekte Zubehörset. Enthält: 4 Boardmarker ( je 1 St. in schwarzrot, blau, grün. 10 Magnete Ø 30mm farbig sortiert. 1 magnetischer Marker- und Zubehörcöcher (weiss). 1 magnetische Box mit 25 Feucht-reinigungstüchern und einem Refillpack mit 25 weiteren Feuchttüchern für die regelmäßige Pflege, nachhaltige Grundreinigung von skin whiteboards und Magnethafter Radierer.

**[FR]** Kit de nettoyage et accessoires.

Comprend : 4 marqueurs couleurs assorties, 10 plots magnétiques de 30 mm de Ø couleurs assorties, pot magnétique pour les marqueurs, paquet de 25 lingettes nettoyantes, une unité de rechange avec 25 lingettes supplémentaires, et Effaceur haute adhérence.



Ref.	cm (embalaje / packaging)	kg / m <sup>3</sup> (embalaje / packaging)
RD-S4319V19	25x11x6	0,55 kg / 0,001 m <sup>3</sup>

## BORRADOR MAGNÉTICO

MAGNETIC ERASER • TAFELLÖSCHER MAGNETISCH • EFFACEUR MAGNÉTIQUE

**[ESP]** Borrador magnético de alta adherencia gracias a su potente imán. Perfecto para pizarras convencionales y pizarras de cristal magnéticas.

**[ENG]** Magnetic eraser with adhesion thanks to its powerful magnet. Perfect for conventional whiteboards and glass magnetic whiteboards

**[DE]** Magnethafter Radierer mit hoher Haftung dank seines starken Magneten. Perfekt für konventionelle und magnetische Glastafeln.

**[FR]** Effaceur haute adhérence grâce a son aimant puissant. Parfait pour tableaux standards et tableaux verres magnétiques.



Ref.	cm (embalaje / packaging)	kg / m <sup>3</sup> (embalaje / packaging)
RD-S4300V19	12x7x3	0,10 kg / 0,001 m <sup>3</sup>

## TOALLITAS

### CLEANING WIPES • FEUCHT-REINIGUNGSTÜCHERN LINGETTES NETTOYANTES

[ESP] Estuche magnético con 25 toallitas de limpieza.

[ENG] Case with 25 cleaning wipes.

[DE] Box mit 25 Feucht-reinigungstüchern.

[FR] Paquet de 25 lingettes nettoyantes.

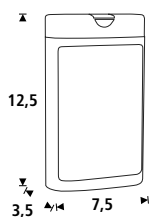

Ref.	cm (embalaje / packaging)	kg / m <sup>3</sup> (embalaje / packaging)
<b>RD-S4320</b> (1 estuche / case)	13x8x4	0,10 kg / 0,001 m <sup>3</sup>

## RECAMBIO PARA TOALLITAS

### REPLACEMENT UNIT • REFILLPACK • UNITÉ DE RECHANGE

[ESP] Recambio de 25 toallitas.

[ENG] Replacement unit with 25 wipes.

[DE] Refillpack mit 25 weiteren Feuchttüchern für die regelmäßige.

[FR] Unité de recharge de 25 lingettes.

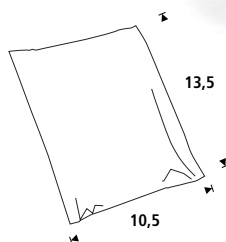

Ref.	cm (embalaje / packaging)	kg / m <sup>3</sup> (embalaje / packaging)
<b>RD-S4321</b> (1 pack)	14x11x2	0,07 kg / 0,001 m <sup>3</sup>

## CUBILETE PARA ROTULADORES

### PENCIL CUP • KÖCHER • POT A CRAYONS

[ESP] Cubilete magnético para rotuladores realizado en polímero técnico.

[ENG] Magnetic pencil cup made in technical polymer.

[DE] Magnetischer Köcher.

[FR] Pot à crayons magnétique.

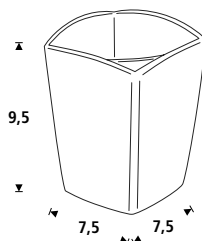

RD-530WH

RD-530GR



Ref.	cm (embalaje / packaging)	kg / m <sup>3</sup> (embalaje / packaging)
<b>RD-530GR</b> verde / green	25x11x6	0,11 kg / 0,001 m <sup>3</sup>
<b>RD-530WH</b> blanco / white	25x11x6	0,11 kg / 0,001 m <sup>3</sup>
<b>RD-530GR*12</b> verde / green (12 u.)	29x22x11	1,35 kg / 0,006 m <sup>3</sup>
<b>RD-530WH*12</b> blanco / white (12 u.)	29x22x11	1,35 kg / 0,006 m <sup>3</sup>



## IMANES

### MAGNETS • MAGNETE • AIMANTS

[ESP] 10 Imanes ø 30 colores mezclados.

[ENG] 10 Magnets ø 30 mixed colours.

[DE] 10 Magnete ø 30 farbig sortiert.

[FR] 10 Aimants ø 30 couleurs assorties.

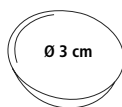

Ref.	cm (embalaje / packaging)	kg / m <sup>3</sup> (embalaje / packaging)	Unidades / units
I4319	6x4x3	0,135 kg / 0,001 m <sup>3</sup>	10 u.

## IMANES "SMILEY"

### "SMILEY" MAGNETS • "SMILEY" MAGNETE • AIMANTS "SMILEY"

[ESP] 15 imanes (5 verde / 5 amarillo / 5 rojo).

[ENG] 15 magnets (5 green / 5 yellow / 5 red).

[DE] 15 Magnete (5 grün / 5 gelb / 5 rot).

[FR] 15 aimants (5 vert / 5 jaune / 5 rouge).



Ref.	cm (embalaje / packaging)	kg / m <sup>3</sup> (embalaje / packaging)	Unidades / units
Smiley15	10x10x1	0,10 kg / 0,001 m <sup>3</sup>	15 (5 x  , 5 x  5 x )

## ROTULADORES

### BOARD MARKERS • TAFELSCHREIBER • MARQUEURS

[ESP] Rotuladores para pizarra blanca, punta redondeada 2-6 mm y uso para borrado en seco.

[ENG] Board markers for whiteboards, 2-6 mm rounded tip, and for dry erasing.

[DE] Tafelschreiber für weisse Tafeln, 2-6 mm Rundspitze, und trocken abwischbar.

[FR] Marqueurs pour tableau blanc, pointe ronde 2-6 mm, et uniquement pour effaçage à sec.

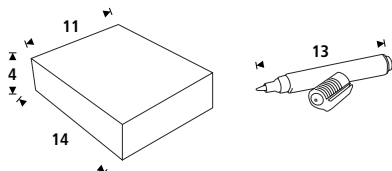

RD-S4040RD\*12



RD-S4040MX\*12

- 6 unidades / units
- 2 unidades / units
- 2 unidades / units
- 2 unidades / units

Ref.	cm (embalaje / packaging)	kg / m <sup>3</sup> (embalaje / packaging)
RD-S4040BK*12 (12u)	14x11x4	0,20 kg / 0,001 m <sup>3</sup>
RD-S4040BL*12 (12u)	14x11x4	0,20 kg / 0,001 m <sup>3</sup>
RD-S4040RD*12 (12u)	14x11x4	0,20 kg / 0,001 m <sup>3</sup>
RD-S4040GR*12 (12u)	14x11x4	0,20 kg / 0,001 m <sup>3</sup>
RD-S4040MX*12 (6+2+2+2u)	14x11x4	0,20 kg / 0,001 m <sup>3</sup>

## ROTULADORES DE TIZA

CHALK MARKERS • KREIDEMARKER • MARQUEURS À CRAIE

**[ESP]** Rotuladores de tiza para superficies lisas como vidrio, azulejos, espejos, metales, plásticos, etc

**[ENG]** Chalk markers for smooth surfaces such as glass, tiles, mirrors, metal, plastics, etc

**[DE]** Kreidemarker für glatte Oberflächen wie Glas, Kacheln, Spiegel, Metall, Kunststoff, etc

**[FR]** Marqueurs à craie pour surfaces lisses, par ex. verre, carreaux, miroirs, métal, plastique, etc.

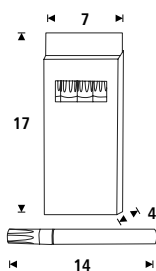

Ref.	cm (embalaje / packaging)	kg / m <sup>3</sup> (embalaje / packaging)	Unidades / units
<b>RD-S5050MX</b>	17x7x2cm	0,8 kg / 0,001 m <sup>3</sup>	4 u.

## FUNDAS MAGNÉTICAS

MAGNETIC SLEEVES MAGNETISCHE DOKUMENTENHALTER • PROTECTIONS MAGNÉTIQUES

**[ESP]** Fundas magnéticas para documentos para todo tipo de usos. Se pueden cambiar los documentos con frecuencia gracias a su estructura de plástico de abertura fácil y que los mantiene limpios en todo momento.

**[ENG]** Magnetic sleeves for any type of document. You can change them frequently thanks to their easy-opening plastic format, which always keeps them clean.

**[DE]** Magnetische Dokumentenhalter. Auf drei Seiten der Rückseite sind Magnetstreifen angebracht, durch die offene Seite können die Dokumente beliebig oft ausgetauscht werden, ohne dass der Dokumentenhalter von seinem Untergrund entfernt werden muss.

**[FR]** Protections magnétiques transparentes pour protéger et changer facilement et à volonté tout type de document.



Ref.	Medidas / size	Unidades / units
<b>RD-S0301A4 (5u.)</b>	A4 (33x24x2)	0,5 kg / 0,001 m <sup>3</sup>
<b>RD-S0301A3 (5u.)</b>	A3 (45x33x2)	1 kg / 0,002 m <sup>3</sup>
<b>RD-S0301A1 (1u.)</b>	A1 (87x63x2)	1 kg / 0,010 m <sup>3</sup>

## SKINNY NOTES

**[ESP]** Notas informativas removibles sin adhesivo. Permite la escritura en ambas caras con todo tipo de rotulador.

**[ENG]** Removable non-adhesive informative notes. Allows writing on both sides with any kind of marker.

**[DE]** Entfernbar Info-Notizen ohne Klebstoff. Ermöglicht das beidseitige Beschreiben mit jeglicher Art von Stift oder Marker.

**[FR]** Note re-positionnable, sans adhésif tout type de marqueur peut être utilisé sur chaque face.



Ref.	Medidas / size	cm (embalaje / packaging)	kg / m <sup>3</sup> (embalaje / packaging)	Hojas / sheets
<b>RD-S4323MX (20x10cm)</b>	20x10 cm	20x10x2	0,30 kg / 0,001 m <sup>3</sup>	400 (100 / color)
<b>RD-S4324MX (12,5x12,5cm)</b>	13x12,5 cm	12,5x12,5x2	0,20 kg / 0,001 m <sup>3</sup>	400 (100 / color)

## SPRAY DE LIMPIEZA

CLEANING SPRAY • REINIGUNGSSPRAY  
SPRAY NETTOYANT

[ESP] Spray de limpieza 250 ml.

[ENG] Cleaning spray 250 ml.

[DE] Reinigungsspray 250 ml.

[FR] Spray nettoyant 250 ml.

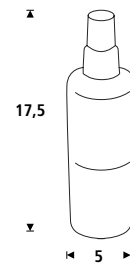

Ref.	cm (embalaje / packaging)	kg / m <sup>3</sup> (embalaje / packaging)
<b>RD-54200</b> (1u. / 250 ml)	19x5x5	0,25 kg / 0,001 m <sup>3</sup>

## BLOC DE PAPEL

PAPER BLOCK • PAPIERBLOCK • BLOC PAPIER

[ESP] Bloc papel 20 hojas. 70 gr. Universal para todas las pizarras.

[ENG] Paper block of 20 sheets of 70 gr. Universal for all boards.

[DE] Papierblock mit 20 Blättern. 70 g. Universell für alle Tafeln.

[FR] Bloc papier 20 feuilles, 70 gr. Universel pour tous les tableaux.

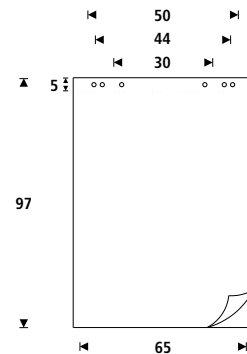

Ref.	cm (embalaje / packaging)	kg / m <sup>3</sup> (embalaje / packaging)
<b>RD-630</b> (1u.)	87x8x8	0,85 kg / 0,010 m <sup>3</sup>
<b>RD-631</b> (5u.)	101x67x1	4,95 kg / 0,007 m <sup>3</sup>

## REVISTERO MAGNÉTICO

WALL LETTER TRAY • MAGNETISCHER WANDBRIEFKORB MAGNETIC CORBEILLE

[ESP] Revistero magnético de gran diseño que admite documentos hasta 24x32cm. Su diseño permite sostener documentos A3 y mantener una fácil accesibilidad. Hasta 2kg. Realizado en poliestireno reciclable. (1 unidad por caja).

[ENG] Magnetic wall letter tray, which can be applied to any metallic surface, carries up to 2 kg. For documents up to A4 size. U-groove on the sides for documents up to A3 format. V-groove on the front panel allow the storage of small documents such as envelopes. (1 unit per box).

[DE] Magnetischer Wandbriefkorb, der sich auf jeder metallischen Fläche anbringen lässt, trägt bis zu 2 kg. Für Dokumente bis DIN A4-Format. U-Aussparung an den Seiten für Dokumente bis DIN A3-Format. V-Aussparung an der Frontseite ermöglicht das Aufbewahren von kleinen Dokumenten wie Briefumschlägen.

[FR] Corbeille murale magnétique, à courrier de paroi, qui peut être appliqué à toute surface métallique, comporte jusqu'à 2 kg. Pour documents jusqu'au format A4. Rainure en U sur les côtés pour les documents jusqu'au format A3. Rainure en V sur le panneau avant permet le stockage de petits documents tels que des enveloppes.

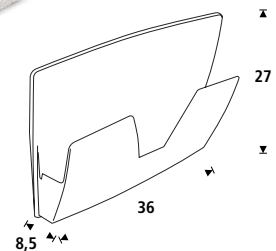

Ref.	cm (embalaje / packaging)	kg / m <sup>3</sup> (embalaje / packaging)
<b>2981GY</b> (Gris / Grey)	38x28x11	0,60 kg / 0,011 m <sup>3</sup>

# PIZARRA TRANSFORMABLE EN MESA

FLIPCHART CONVERTIBLE INTO TABLE • MOBILES MULTIFUNKTIONSFLIPCHART  
TABLEAU TRANSFORMABLE EN TABLE

**[ESP]** Pizarra móvil metálica, magnética para escritura con rotuladores de borrado en seco. Admite bloc de papel universal. Regulable en altura mediante muelles. Su regulación permite trabajar sentado para gente con algún tipo de discapacidad. Convertible en mesa. Incluye 2 brazos telescópicos. Fácil montaje.

**[ENG]** Mobile, flipchart with quality magnetic, dry-wipe surface. The surface revolves 90° to allow a flat working surface to use as an AV stand or table. Height adjustable through a smooth spring mechanism. Can be used at sitting height for disabled or wheelchair users. Universal fixings for flipchart pad. 2 telescopic arms for additional presentation. Easy to assemble.

**[DE]** Mobiles Multifunktions-Flipchart mit magnethaftender, hochwertig beschichteter Oberfläche und besonders stabilem Metall-Rundfuß. Kann trocken abwischbar beschriftet werden. Die Tafelfläche lässt sich um 90° kippen und als temporäre Tischfläche nutzen. Höhenverstellbar mittels Spiralfeder. Die untere Höheneinstellung ermöglicht ein Arbeiten am Flipchart auch im Sitzen, somit eignet sich dieses Flipchartmodell u.a. auch gut für Rollstuhlfahrer. Schnellwechselblockhalter für marktübliche Flipchart-Papierblöcke. Zwei seitliche einsteckbare Konzepthalter erweitern die Präsentationsfläche bei Bedarf. Einfache Montage.

**[FR]** Tableau métallique mobile, aimanté, pour écriture avec feutres. Peut recevoir des blocs de papier universels. Réglable en hauteur par système à ressort. L'amplitude de réglage permet de travailler en position assise (par exemple pour handicapés en chaise roulante). Transformable en table. Dispose de deux bras télescopiques latéraux. Montage facile.

CERTIFICADA  
CERTIFIED



Superficie para rotuladores de borrado en seco.  
No limpiar con alcohol o productos abrasivos.

Dry wipe surface. Never clean it with alcohol or abrasive products.

Bitte niemals mit reinem Alkohol reinigen und keine Tücher mit abrasiven Eigenschaften verwenden.

Surface effaçable à sec. Ne nettoyer jamais la surface avec de l'alcool ou un produit abrasif.



Incluye un rotulador  
Marker included

Ideal para proyector  
Ideal for projector



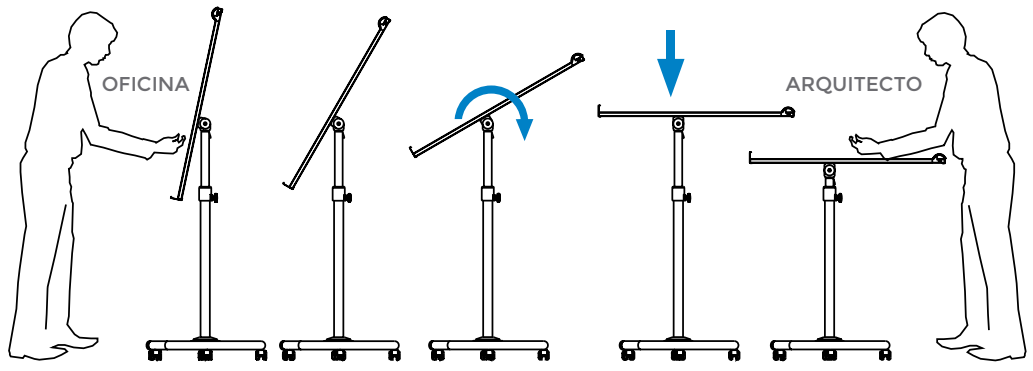
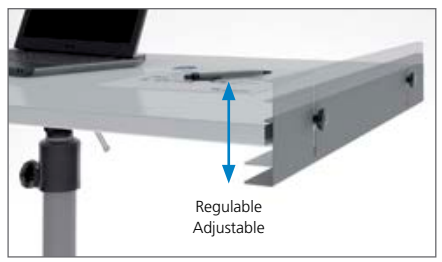

Medidas / Sizes (cm)

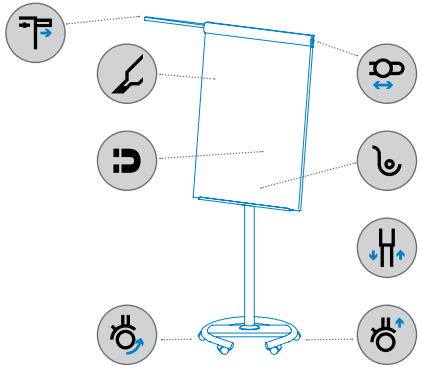
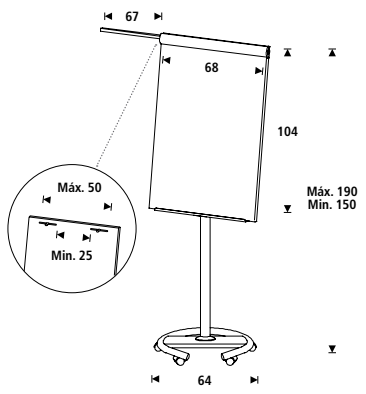

**RD-619**  
Bandeja porta útiles de cristal  
Optional glass tray

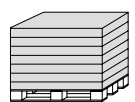

**RD-618V15** - palet / pallet 8 u. - 80x120x120 cm

Ref.	cm (embalaje / packaging)	kg / m <sup>3</sup> (embalaje / packaging)	Color
○ <b>RD-618</b>	118x79x9	18,65 kg / 0,083 m <sup>3</sup>	
● <b>RD-618-630</b>	118x79x9	18,65 kg / 0,083 m <sup>3</sup>	RAL 630
<b>RD-619</b> opcional / optional	70x35x8	3 kg / 0.019 m <sup>3</sup>	

# PIZARRAS MÓVILES

MOBILE FLIPCHARTS • MOBILE FLIPCHARTS • TABLEAUX MOBILES

**[ESP]** Pizarra móvil metálica, magnética y curvada con sistema patentado Flip-Roll de serie. Sólo papelógrafo. Permite trabajar con rollo o con bloc de papel universal. Regulación de altura mediante muelle. Incluye un brazo telescópico y rollo de papel K-635 de 35m. Fácil montaje.

**[ENG]** Mobile magnetic, metallic and curved flipchart, with patented flip-roll system, "only papergraph". Allows working with roll or universal paper block. Height adjustment through a spring. Telescopic arm and paper block K-635 included. Easy assembly.

**[DE]** Mobiles Metallflipchart mit geschwungener Tafeloberfläche und patentiertem Flip Roll System. Verwendbar mit einer Papierrolle oder mit einem Universalpapierblock. Hochwertige Metallic-Pulverbeschichtung. Höhenverstellung 170 – 200 cm mittels Spiralfeder. Mit Bildhalter.

**[FR]** Tableau de conférence magnétique, mobile, métal, galbé, avec système exclusif breveté flip-roll, "seulement papiergraph". Permet l'utilisation de rouleau de papier ou de bloc papier universel. Réglage en hauteur assisté par ressort. Avec bras télescopique et rouleau papier K-635. Facile à monter.



Incluye un rotulador  
Marker included



**K-635**  
 Rollo de papel de 35m para RD 660  
 35m Paper roll for: RD 660  
 35m Papierrolle für: RD 660  
 Rouleau papier 35 m pour: RD 660



**RD-619**  
 Bandeja porta útiles de cristal  
 Optional glass tray



Brazo telescópico  
 Telescopic arm



Ruedas a presión  
 Click system castors



Sujeción del rollo de papel  
 Paper roll fastening



Bandeja para rotulador  
 Marker tray

Medidas / Sizes (cm)

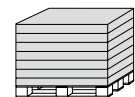
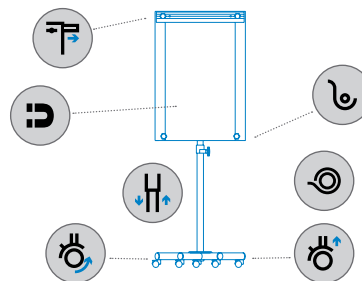
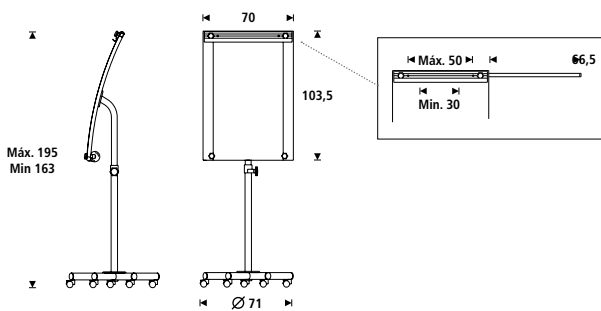

**RD-660** - palet / pallet 5 u. - 80x120x115 cm

Ref.	cm (embalaje / packaging)	kg / m <sup>3</sup> (embalaje / packaging)
<b>RD-660</b>	77x21x113	21,5 kg / 0,183 m <sup>3</sup>
<b>K-635</b> opcional / optional	68x8x8	1,85 kg / 0,010 m <sup>3</sup>
<b>RD-619</b> opcional / optional	70x35x8	3 kg / 0.019 m <sup>3</sup>

# PIZARRAS MÓVILES

MOBILE FLIPCHARTS • MOBILE FLIPCHARTS • TABLEAUX MOBILES

**[ESP]** Pizarra móvil metálica, magnética para escritura con rotuladores de borrado en seco. Admite bloc de papel universal. Regulable en altura mediante muelles. Incluye 2 brazos telescópicos. Fácil montaje.

**[ENG]** Mobile, flipchart with quality magnetic, dry-wipe surface. Height adjustable through a smooth spring mechanism. Universal fixings for flipchart pad. 2 telescopic arms for additional presentation. Easy to assemble.

**[DE]** Mobiles Flipchart mit stabilem, ergonomisch geformtem Metall-Rundfuß. Die neuartige, patentierte Höhenverstellung mit Federmechanismus und Sicherheitssperre ermöglicht die stufenlose Einstellung der individuellen Arbeitshöhe. Der Schnellwechselblockhalter mit Klappmechanik ist für alle handelsüblichen Flipchartblocks geeignet. Die Pulverbeschichtung der Tafel gewährleistet grundsätzlich gute Beschriftungs- und Abwischeigenschaften für Boardmarker auf Alkoholbasis. Zwei seitlich einsteckbare, magnethaftende Papierhalter erweitern die Präsentationsfläche auf das dreifache. Ablageleiste aus Metall.

**[FR]** Tableau métallique mobile, aimanté, pour écriture avec feutres. Peut recevoir des blocs de papier universels. Réglable en hauteur par système à ressort. Dispose de deux bras télescopiques latéraux. Montage facile.



Incluye un rotulador  
Marker included



Superficie para rotuladores de borrado en seco.  
No limpiar con alcohol o productos abrasivos.

Dry wipe surface. Never clean it with alcohol or abrasive products.

Bitte niemals mit reinem Alkohol reinigen und keine Tücher mit abrasiven Eigenschaften verwenden.

Surface effaçable à sec. Ne nettoyer jamais la surface avec de l'alcool ou un produit abrasif.





Sistema bloc de paper universal  
Universal paper block system

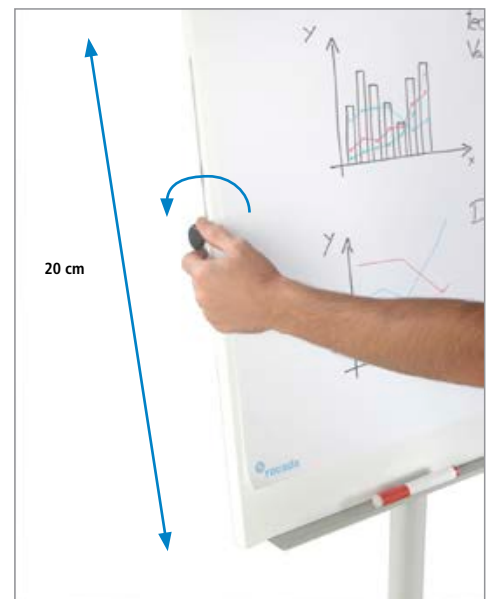

Medidas / Sizes (cm)

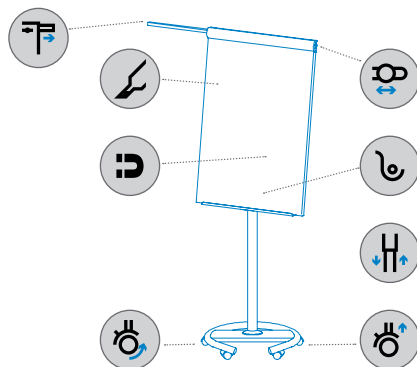
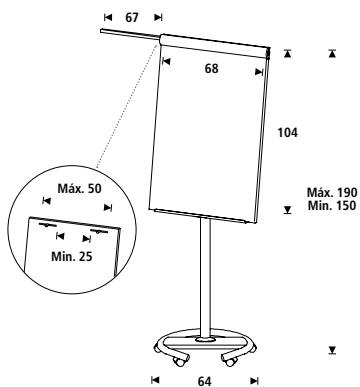

**RD-619**  
Bandeja porta útiles de cristal  
Optional glass tray

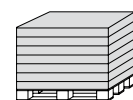

**RD-617V15** - palet / pallet 8 u. - 80x120x120 cm

Ref.	cm (embalaje / packaging)	kg / m <sup>3</sup> (embalaje / packaging)	Color
<b>RD-617</b>	116x80x10	17,3 kg / 0,093 m <sup>3</sup>	○
<b>RD-617-630</b>	116x80x10	17,3 kg / 0,093 m <sup>3</sup>	● RAL 630
<b>RD-619 opcional / optional</b>	70x35x8	3 kg / 0.019 m <sup>3</sup>	

# PIZARRAS MÓVILES

MOBILE FLIPCHARTS • MOBILE FLIPCHARTS • TABLEAUX MOBILES

**[ESP]** Pizarra móvil metálica y magnética, apta para escritura con rotuladores de borrado en seco. Admite bloc de papel universal. No regulable en altura. Incluye 1 brazo telescópico. Fácil montaje.

**[ENG]** Mobile magnetic metal flipchart for writing with dry-wipe markers. Takes universal paper block. Not height-adjustable. Includes 1 telescopic arm. Easy to assemble.

**[DE]** Funktionell und mit der Konzentration auf das Wesentliche – das mobile Flipchart mit fester Aufstellhöhe. Stabiler Kunststofffuß. Magnethaftende Tafeloberfläche, für trocken abwischbare Beschriftung geeignet. Schnellwechselblockhalter für marktübliche Flipchart-Papierblöcke. 1 Inklusive Teleskoparm. Feststellbare Laufrollen.

**[FR]** Tableau mobile métallique, magnétique pour écriture au marqueur effaçable à sec. Peut recevoir bloc de papier universel. Non réglable en hauteur. N'admet pas de bras télescopiques. Inclut 1 bras télescopique. Facile à monter.

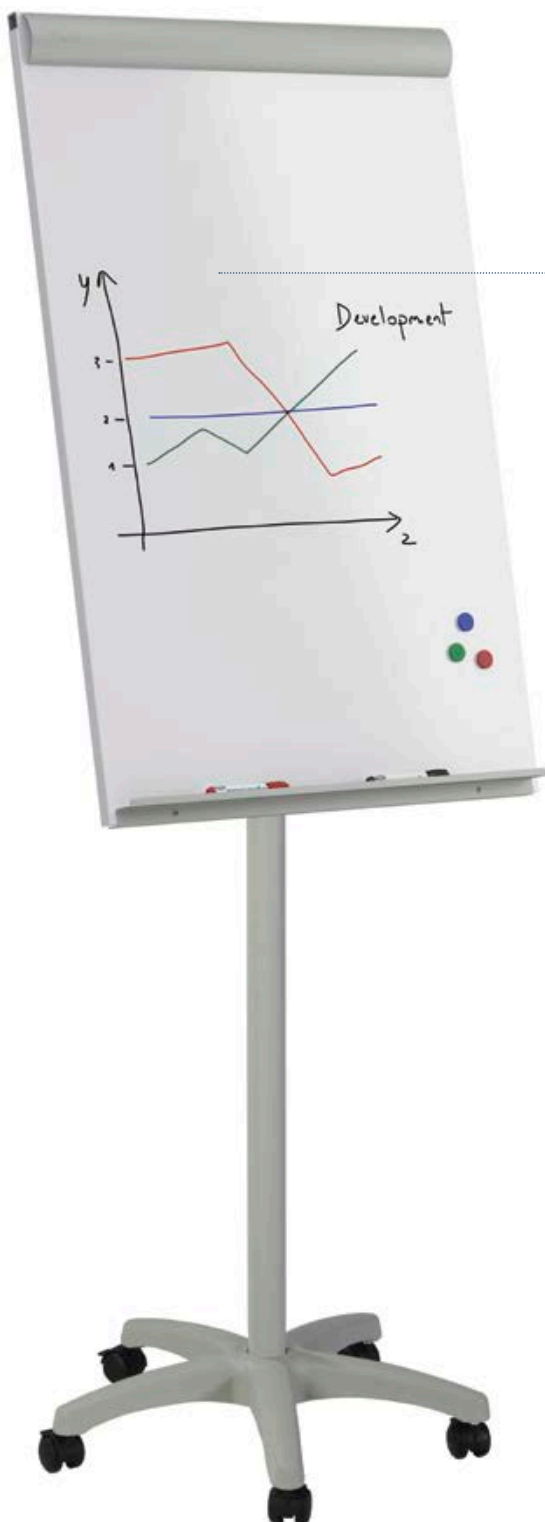

Superficie para rotuladores de borrado en seco.  
No limpiar con alcohol o productos abrasivos.

Dry wipe surface. Never clean it with alcohol or abrasive products.

Bitte niemals mit reinem Alkohol reinigen und keine Tücher mit abrasiven Eigenschaften verwenden.

Surface effaçable à sec. Ne nettoyer jamais la surface avec de l'alcool ou un produit abrasif.



Incluye un rotulador  
Marker included



Sistema bloc de papel universal / Universal paper block system



Ruedas a presión  
Click system castors

Medidas / Sizes (cm)

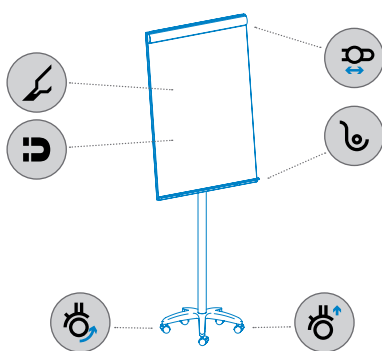
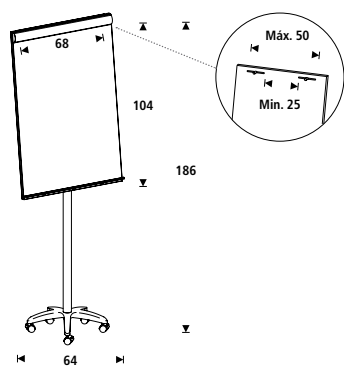

**RD-619**  
Bandeja porta útiles de cristal  
Optional glass tray

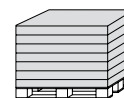

**RD-616** - palet / pallet 8 u. - 80x120x120 cm

Ref.	cm (embalaje / packaging)	kg / m <sup>3</sup> (embalaje / packaging)	Color
<b>RD-616</b>	115x79x12	13,7 kg / 0,108 m <sup>3</sup>	blanco / white ○
<b>RD-616-630*</b>	115x79x12	13,7 kg / 0,108 m <sup>3</sup>	RAL 630 ●
<b>RD-619</b> opcional / optional	70x35x8	3 kg / 0.019 m <sup>3</sup>	

# PIZARRAS TRÍPODE

TRIPOD FLIPCHARTS • FLIPCHART BUSINESS • TABLEAU TRIPODE

**[ESP]** Pizarra trípode metálica y magnética de gran estabilidad, apta para escritura con rotuladores de borrado en seco. Admite bloc de papel universal. Regulación de altura total. Incluye 1 brazo telescópico. Fácil montaje

**[ENG]** Magnetic metal tripod flipchart for writing with dry-wipe markers. Takes universal paper block. Height-adjustable. Includes 1 telescopic arm. Easy to assemble.

**[DE]** Dreibein-Flipchart aus Metall, magnethaftend und trocken abwischbar zu beschreiben. Für marktübliche Flipchart-Papierblöcke. Höhenverstellbar. Mit seitlich einsteckbarem Konzepthalter. Einfach aufzubauen.

**[FR]** Tableau trípode métallique, magnétique, pour écriture au marqueur effaçable à sec. Peut recevoir bloc de papier universel. Réglable en hauteur. Inclut un bras télescopique. Facile à monter.



Superficie para rotuladores de borrado en seco.  
No limpiar con alcohol o productos abrasivos.

Dry wipe surface. Never clean it with alcohol or abrasive products.

Bitte niemals mit reinem Alkohol reinigen und keine Tücher mit abrasiven Eigenschaften verwenden.

Surface effaçable à sec. Ne nettoyer jamais la surface avec de l'alcool ou un produit abrasif.



Incluye un rotulador  
Marker included



Sistema bloc de papel universal / universal paper block system

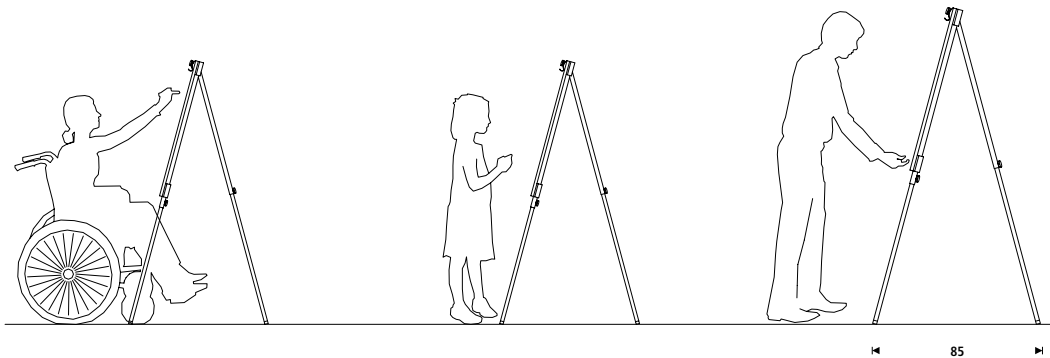

Medidas / Sizes (cm)

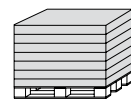
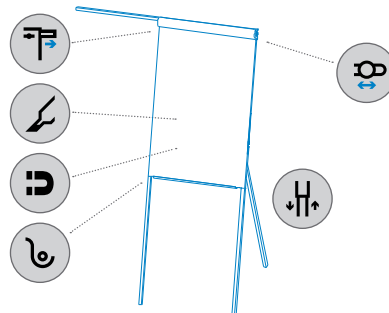
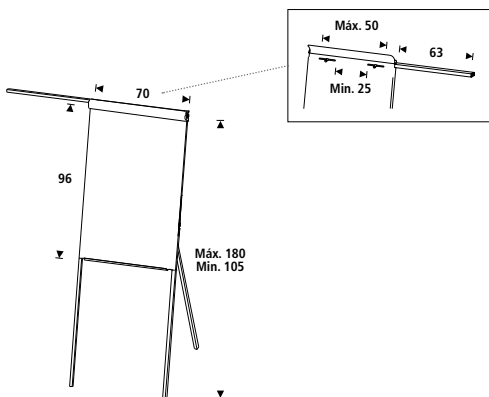

RD-610V19 - palet / pallet 30 u. - 80x120x170 cm

Ref.	cm (embalaje / packaging)	kg / m <sup>3</sup> (embalaje / packaging)	Color
RD-610V19	102x72x4	13,30 kg / 0,030 m <sup>3</sup>	blanco / white <span style="color: white; border: 1px solid black; border-radius: 50%; padding: 2px;">○</span>
RD-610V19-630*	102x72x4	13,30 kg / 0,030 m <sup>3</sup>	RAL 630 <span style="color: blue; border: 1px solid blue; border-radius: 50%; padding: 2px;">●</span>

# PIZARRAS TRÍPODE

TRIPOD FLIPCHARTS • FLIPCHART BUSINESS • TABLEAU TRIPODE

**[ESP]** Pizarra trípode de melamina de gran estabilidad, apta para escritura con rotuladores de borrado en seco. Admite bloc de papel. Regulación de altura total facilitando la escritura a niños o personas con movilidad reducida. Fácil montaje.

**[ENG]** Tripod Flipchart with metallic structure and melamine dry-wipe surface, height adjustable, easy assembly.

**[DE]** Economy – Flipchart-Stativ mit melaminbeschichteter Oberfläche und Standardblockhalter. Einfache Montage.

**[FR]** Tableau mélaminé, trois pieds, non aimanté, pour écriture avec feutres. Réglable en hauteur. Pas de bras télescopique. Montage facile.



Superficie para rotuladores de borrado en seco.  
No limpiar con alcohol o productos abrasivos.  
Dry wipe surface. Never clean it with alcohol or abrasive products.  
Bitte niemals mit reinem Alkohol reinigen und keine Tücher mit abrasiven Eigenschaften verwenden.  
Surface effaçable à sec. Ne nettoyer jamais la surface avec de l'alcool ou un produit abrasif.



1A01424  
Versión montada disponible  
Assembled version available



Incluye un rotulador  
Marker included



Pinza y bandeja - Paper clamp and pen tray

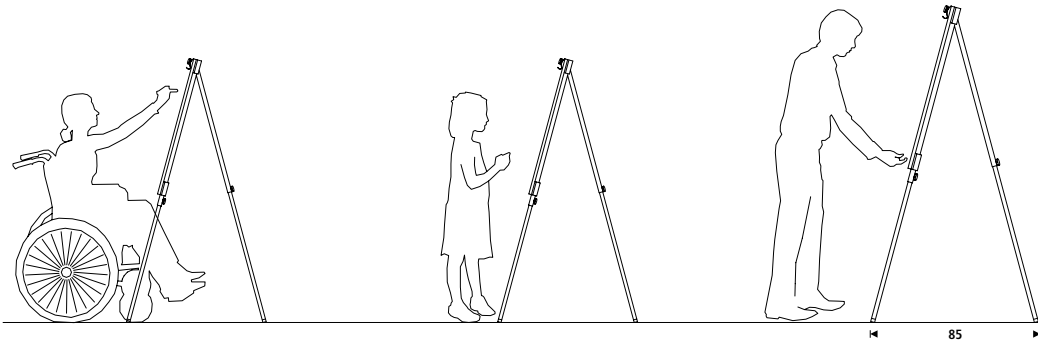

Medidas / Sizes (cm)

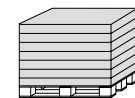
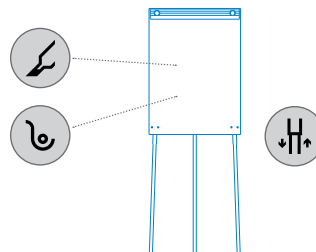
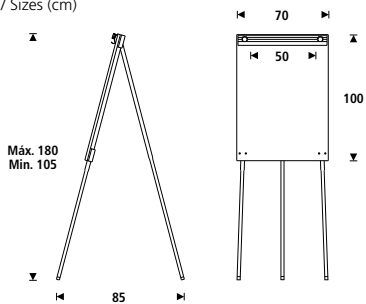

**RD-600** - palet / pallet 20 u. - 80x120x120 cm  
**1A01424** - palet / pallet 10 u. - 80x120x120 cm

Ref.	cm (embalaje / packaging)	kg / m <sup>3</sup> (embalaje / packaging)
<b>RD-600</b>	104x73x5	11,20 kg / 0,037 m <sup>3</sup>
<b>1A01424</b> - montada / assembled	110x75x9	11,20 kg / 0,074 m <sup>3</sup>

# VITRINA INTERIOR / INDOOR

DISPLAY CABINET • SCHAUKASTEN INNENBEREICH (WHITEBOARD) • VITRINE

**[ESP]** Vitrina realizada en aluminio extruido, ligera y de fácil instalación. Superficie magnética lacada en blanco (apta para rotuladores de borrado en seco). Puertas correderas fabricadas en cristal de seguridad, ideal para espacios reducidos. Trasera adicional de acero cincado. Se suministra con cerradura y 2 llaves universales. Incluye accesorios para la fijación a la pared. Profundidad útil 18,6mm. Profundidad total 46mm.

**[ENG]** Display cabinet made in extruded aluminium, light and easy to install, with lacquered (dry-wipe) metal surface. With sliding doors of ESG glass, ideal for small spaces. Zink steel extra backing. Supplied with 2 universal keys and accessories for wall fixing. Usable depth 18.6 mm. Total depth 46 mm.

**[DE]** Schaukasten aus stranggepresstem Aluminium mit lackierter, magnethaftender Aushangfläche. Dank leichter Bauweise einfach zu montieren. Mit 5mm dicken ESG-Schiebetüren, abschliessbar. 2 Universalschlüssel und Zubehör für die Wandmontage im Lieferumfang enthalten. Nutztiefe 18,6 mm, Gesamttiefe 46 mm.

**[FR]** Vitrine réalisée en aluminium extrudé, légère et facile à installer. Surface magnétique laqué en blanc (marqueurs appropriés pour effaçable à sec). Portes coulissantes en verre securit, idéal pour espaces réduits. Arrière supplémentaire d'acier galvanisé. Livrée avec 2 clés universelles. Accessoires pour le montage mural inclus. Profondeur utile 18,6mm. Profondeur totale 46mm.

**MEJORADA  
IMPROVED**

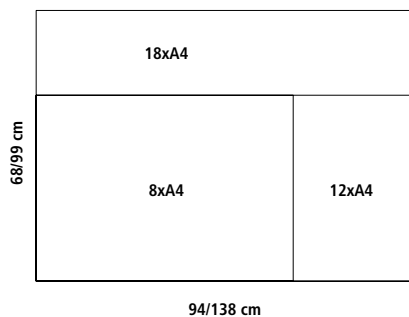
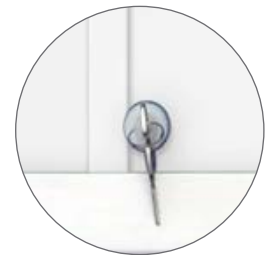
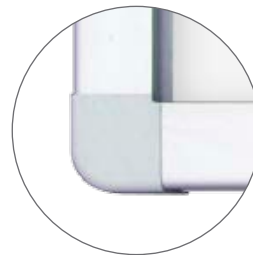

Ref.	cm (embalaje / packaging)	kg / m <sup>3</sup> (embalaje / packaging)
<b>RD-3641V17</b> (94x68 cm) (8xA4)	100x74x8	13,50 kg / 0,055 m <sup>3</sup>
<b>RD-3642V17</b> (138x68 cm) (12xA4)	145x74x8	20,00 kg / 0,080 m <sup>3</sup>
<b>RD-3644V17</b> (138x99 cm) (18xA4)	145x105x8	27,60 kg / 0,114 m <sup>3</sup>



# VITRINA INTERIOR / INDOOR

DISPLAY CABINET • SCHAUKASTEN INNENBEREICH (CORK-PINNBOARD) • VITRINE

**[ESP]** Vitrina realizada en aluminio extruido, ligera y de fácil instalación. Superficie de corcho natural resistente y autorregenerable. Puertas correderas fabricadas en cristal de seguridad, ideal para espacios reducidos. Trasera adicional de acero cincado. Se suministra con cerradura y 2 llaves universales. Incluye accesorios para la fijación a la pared. Profundidad útil 18.6mm. Profundidad total 46mm.

**[ENG]** Display cabinet made in extruded aluminium, light and easy to install, with cork surface. With sliding doors of ESG glass, ideal for small spaces. Zinc steel extra backing. Supplied with 2 universal keys and accessories for wall fixing. Usable depth 18.6 mm. Total depth 46 mm.

**[DE]** Schaukasten aus stranggepresstem Aluminium mit Aushangfläche aus Kork. Dank leichter Bauweise einfach zu montieren. Mit 5mm dicken ESG-Schiebetüren, abschliessbar. 2 Universalschlüssel und Zubehör für die Wandmontage im Lieferumfang enthalten. Nutztiefe 18,6mm, Gesamttiefe 46 mm.

**[FR]** Vitrine réalisée en aluminium extrudé, légère et facile à installer. Surface en liège. Portes coulissantes en verre securit, idéal pour espaces réduits. Arrière supplémentaire d'acier galvanisé. Livrée avec 2 clés universelles. Accessoires pour le montage mural inclus. Profondeur utile 18,6mm. Profondeur totale 46mm.

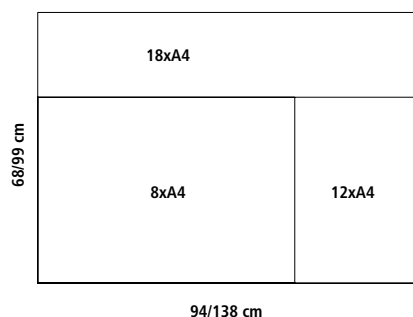

Ref.	cm (embalaje / packaging)	kg / m <sup>3</sup> (embalaje / packaging)
<b>RD-3651V17</b> (94x68 cm) (8xA4)	100x74x8	13,50 kg / 0,055 m <sup>3</sup>
<b>RD-3652V17</b> (138x68 cm) (12xA4)	145x74x8	18,50 kg / 0,080 m <sup>3</sup>
<b>RD-3654V17</b> (138x99 cm) (18xA4)	145x105x8	25,20 kg / 0,114 m <sup>3</sup>

# VITRINA INTERIOR / INDOOR

DISPLAY CABINET • SCHAUKASTEN INNENBEREICH (PINNBOARD) • VITRINE

**[ESP]** Vitrina realizada en aluminio extruido, ligera y de fácil instalación. Superficie tapizada. Puertas correderas fabricadas en cristal de seguridad, ideal para espacios reducidos. Trasera adicional de acero cincado. Se suministra con cerradura y 2 llaves universales. Incluye accesorios para la fijación a la pared. Profundidad útil 18,6mm. Profundidad total 46mm.

**[ENG]** Display cabinet made in extruded aluminium, light and easy to install, with upholstered surface. With sliding doors of ESG glass, ideal for small spaces. Zinc steel extra backing. Supplied with 2 universal keys and accessories for wall fixing. Usable depth 18.6 mm. Total depth 46 mm.

**[DE]** Schaukasten aus stranggepresstem Aluminium mit stoffbezogener Aushangfläche. Dank leichter Bauweise einfach zu montieren. Mit 5mm dicken ESG-Schiebetüren, abschliessbar. 2 Universalschlüssel und Zubehör für die Wandmontage im Lieferumfang enthalten. Nutztiefe 18,6 mm. Gesamttiefe 46 mm.

**[FR]** Vitrine réalisée en aluminium extrudé, légère et facile à installer. Surface tapissée. Portes coulissantes en verre securit, idéal pour espaces réduits. Arrière supplémentaire d'acier galvanisé. Livrée avec 2 clés universelles. Accessoires pour le montage mural inclus. Profondeur utile 18,6mm. Profondeur totale 46mm.

MEJORADA  
IMPROVED

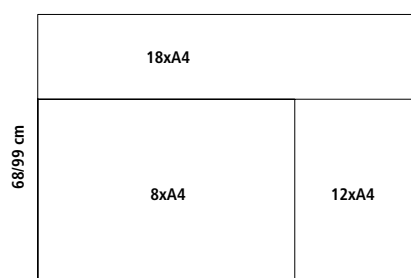

94/138 cm



Ref.	cm (embalaje / packaging)	kg / m <sup>3</sup> (embalaje / packaging)
<b>RD-3661V17</b> (94x68 cm) (8xA4)	100x74x8	13,50 kg / 0,055 m <sup>3</sup>
<b>RD-3662V17</b> (138x68 cm) (12xA4)	145x74x8	18,50 kg / 0,080 m <sup>3</sup>
<b>RD-3664V17</b> (138x99 cm) (18xA4)	145x105x8	25,20 kg / 0,114 m <sup>3</sup>

# VITRINA INTERIOR / INDOOR

DISPLAY CABINET • AUSHANG-VITIRINE (WHITEBOARD) FÜR INNENBEREICH) • VITRINE

**[ESP]** Vitrina realizada en aluminio extruido, ligera y de fácil instalación con marco reforzado. Superficie magnética lacada en blanco (apta para rotuladores de borrado en seco). Puerta batiente fabricada en policarbonato de alta visibilidad. Trasera adicional de acero cincado. Se suministra con cerradura mediante 2 tornillos allen. Incluye accesorios para la fijación a la pared. Profundidad útil 12mm. Profundidad total 38 mm.



**[ENG]** Display cabinet made in extruded aluminium, light and easy to install, with lacquered (dry-wipe) metal surface. With casement-opening doors of polycarbonate. Zink steel extra backing. Supplied with 2 allen keys and accessories for wall fixing. Usable depth 12 mm. Total depth 38 mm.

**[DE]** Funktionelle Whiteboard-Vitrine. Mit horizontal öffnender Kunststoffglastür (Innenanwendung). Rahmen aus stranggepresstem Aluminium mit Kunststoffverbindern. Lackierte, magnetisierende Metallinnenfläche. 2 Universalschlüssel und Zubehör für die Wandmontage im Lieferumfang enthalten. Nutztiefe 12 mm. Gesamttiefe 38 mm.

**[FR]** Vitrine réalisée en aluminium extrudé, légère et facile à installer. Surface magnétique laqué en blanc (marqueurs appropriés pour effaçable à sec). Porte battante en polycarbonate haute visibilité dos en acier galvanisé. Accessoires pour le montage mural inclus. Profondeur utile 12mm. Profondeur totale 38mm.



Marco reforzado  
Enhanced frame

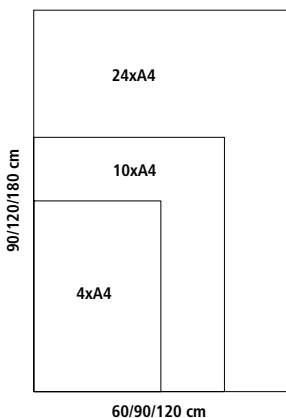

Ref.	cm (embalaje / packaging)	kg / m <sup>3</sup> (embalaje / packaging)
<b>RD-3676V17</b> (90x60 cm) (4xA4)	96x66x8	9,60 kg / 0,047 m <sup>3</sup>
<b>RD-3679V17</b> (120x90 cm) (10xA4)	126x96x8	16,00 kg / 0,090 m <sup>3</sup>
<b>RD-3680V17</b> (180x120 cm) (24xA4)	189x126x8	30,00 kg / 0,178 m <sup>3</sup>

# VITRINA INTERIOR / INDOOR

## DISPLAY CABINET

### AUSHANG-VITIRINE (KORK-PINNBOARD) FÜR INNENBEREICH • VITRINE

**[ESP]** Vitrina realizada en aluminio extruido, ligera y de fácil instalación con marco reforzado. Superficie de corcho natural resistente y autorregenerable. Puerta batiente fabricada en policarbonato de alta visibilidad. Trasera adicional de acero cincado. Se suministra con cerradura mediante 2 tornillos allen. Incluye accesorios para la fijación a la pared. Profundidad útil 12mm. Profundidad total 38 mm.



**[ENG]** Display cabinet made in extruded aluminium, light and easy to install, with cork surface. With casement-opening doors of polycarbonate. Zink steel extra backing. Supplied with 2 allen keys and accessories for wall fixing. Usable depth 12 mm. Total depth 38 mm.

**[DE]** Funktionelle Korkboard-Vitrine. Mit horizontal öffnender Kunststoffglastür (Innenanwendung). Rahmen aus stranggepresstem Aluminium mit Kunststoffverbindern. Aushangfläche aus Kork. 2 Universalschlüssel und Zubehör für die Wandmontage im Lieferumfang enthalten. Nutztiefe 12 mm. Gesamttiefe 38 mm.

**[FR]** Vitrine réalisée en aluminium extrudé, légère et facile à installer. Surface en liège. Porte battante en polycarbonate haute visibilité. Arrière supplémentaire d'acier galvanisé. Accessoires pour le montage mural inclus. Profondeur utile 12mm. Profondeur totale 38mm.



Marco reforzado  
Enhanced frame

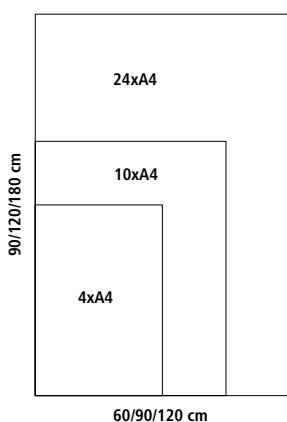
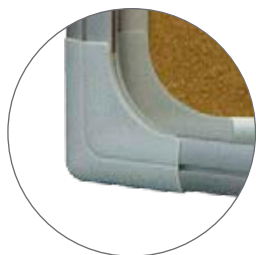

Ref.	cm (embalaje / packaging)	kg / m <sup>3</sup> (embalaje / packaging)
<b>RD-3686V17</b> (90x60 cm) (4xA4)	96x66x8	7,40 kg / 0,047 m <sup>3</sup>
<b>RD-3689V17</b> (120x90 cm) (10xA4)	126x96x8	12,80 kg / 0,090 m <sup>3</sup>
<b>RD-3690V17</b> (180x120 cm) (24xA4)	189x126x8	27,00 kg / 0,178 m <sup>3</sup>

# VITRINA INTERIOR / INDOOR

## DISPLAY CABINET

### AUSHANG-VITIRINE (PINNBOARD) FÜR INNENBEREICH • VITRINE

**[ESP]** Vitrina realizada en aluminio extruido, ligera y de fácil instalación con marco reforzado. Superficie tapizada. Puerta batiente fabricada en policarbonato de alta visibilidad. Trasera adicional de acero cincado. Se suministra con cerradura mediante 2 tornillos allen. Incluye accesorios para la fijación a la pared. Profundidad útil 12mm. Profundidad total 38 mm.

**[ENG]** Display cabinet made in extruded aluminium, light and easy to install, with upholstered surface. With casement-opening doors of polycarbonate. Zink steel extra backing. Supplied with 2 allen keys and accessories for wall fixing. Usable depth 12 mm. Total depth 38 mm.

**[DE]** Funktionelle Pinnboard-Vitrine. Mit horizontal öffnender Kunststoffglastür (Innenanwendung). Rahmen aus stranggepresstem Aluminium mit Kunststoffverbindern. Aushangfläche aus blauem Stoff. 2 Universalschlüssel und Zubehör für die Wandmontage im Lieferumfang enthalten. Nutztiefe 12 mm. Gesamttiefe 38 mm.

**[FR]** Vitrine réalisée en aluminium extrudé, légère et facile à installer. Surface tapissée. Porte battante en polycarbonate haute visibilité. Dos en acier galvanisé. Accessoires pour le montage mural inclus. Profondeur utile 12mm. Profondeur totale 38mm.



Marco reforzado  
Enhanced frame

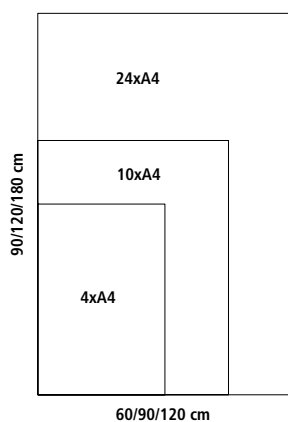
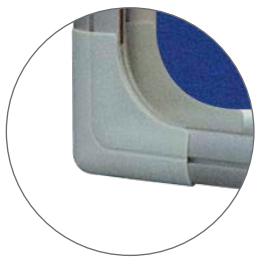

Ref.	cm (embalaje / packaging)	kg / m <sup>3</sup> (embalaje / packaging)
<b>RD-3696V17</b> (90x60 cm) (4xA4)	96x66x8	8,00 kg / 0,047 m <sup>3</sup>
<b>RD-3699V17</b> (120x90 cm) (10xA4)	126x96x8	14,00 kg / 0,090 m <sup>3</sup>
<b>RD-3700V17</b> (180x120 cm) (24xA4)	189x126x8	27,00 kg / 0,178 m <sup>3</sup>

# VITRINA INTERIOR / EXTERIOR INDOOR/OUTDOOR

DISPLAY CABINET • SCHAUKASTEN AUSSENBEREICH (WHITEBOARD) • VITRINE

**[ESP]** Vitrina realizada en aluminio extruido, ligera y de fácil instalación con marco reforzado. Superficie magnética lacada en blanco (apta para rotuladores de borrado en seco). Puerta abatible de apertura vertical en policarbonato de alta visibilidad, ideal para espacios reducidos. Trasera adicional de acero cincado. Se suministra con cerradura y 2 llaves universales. Incluye accesorios para la fijación a la pared. Profundidad útil 24mm. Profundidad total 48 mm.

**[ENG]** Display cabinet made in extruded aluminium, light and easy to install, with lacquered (dry-wipe) metal surface. With vertical-opening doors of polycarbonate, ideal for small spaces. Zinc steel extra backing. Supplied with 2 universal keys and accessories for wall fixing. Usable depth 24 mm. Total depth 48 mm.

**[DE]** Außenbereich-geeigneter Schaukasten aus stranggepresstem Aluminium Mit lackierter, magnethaftender Aushangfläche. Vertikal zu öffnende, transparente Kunststoffabdeckung. 2 Universalschlüssel und Zubehör für die Wandmontage im Lieferumfang enthalten. Nutztiefe 24 mm. Gesamttiefe 48 mm.

**[FR]** Vitrine réalisée en aluminium extrudé, légère et facile à installer. Surface magnétique laquée blanche (marqueurs appropriés pour effaçable à sec). Porte à ouverture vertical en polycarbonate haute visibilité, idéal pour les espaces réduits. Dos en acier galvanisé. Accessoires pour le montage mural inclus. Profondeur utile 24mm. Profondeur totale 48mm.

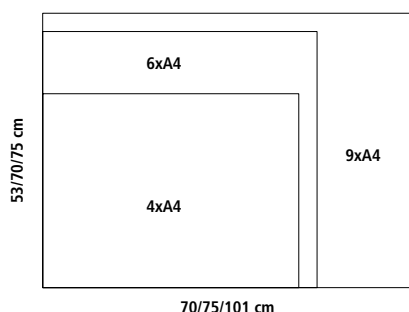

Ref.	cm (embalaje / packaging)	kg / m <sup>3</sup> (embalaje / packaging)
<b>RD-3671V17EX</b> (70x53 cm) (4xA4)	76x59x8	8,80 kg / 0,033 m <sup>3</sup>
<b>RD-3672V17EX</b> (75x70 cm) (6xA4)	81x76x8	10,60 kg / 0,046 m <sup>3</sup>
<b>RD-3673V17EX</b> (101x75 cm) (9xA4)	107x81x8	18,20 kg / 0,065 m <sup>3</sup>

# VITRINA INTERIOR / EXTERIOR INDOOR/OUTDOOR

DISPLAY CABINET • SCHAUKASTEN AUSSENBEREICH (KORK-PINNBOARD) • VITRINE

**[ESP]** Vitrina realizada en aluminio extruido, ligera y de fácil instalación con marco reforzado. Superficie de corcho natural resistente y autorregenerable. Puerta abatible de apertura vertical en policarbonato de alta visibilidad, ideal para espacios reducidos. Trasera adicional de acero cincado. Se suministra con cerradura y 2 llaves universales. Incluye accesorios para la fijación a la pared. Profundidad útil 24mm. Profundidad total 48 mm.

**[ENG]** Display cabinet made in extruded aluminium, light and easy to install, with cork surface. With vertical-opening doors of polycarbonate, ideal for small spaces. Zinc steel extra backing. Supplied with 2 universal keys and accessories for wall fixing. Usable depth 24 mm. Total depth 48 mm.

**[DE]** Außenbereich-geeigneter Schaukasten aus stranggepresstem Aluminium Mit Aushangfläche aus Korkmaterial. Vertikal zu öffnende, transparente Kunststoffabdeckung. 2 Universalschlüssel und Zubehör für die Wandmontage im Lieferumfang enthalten. Nutztiefe 24 mm. Gesamttiefe 48 mm.

**[FR]** Vitrine réalisée en aluminium extrudé, légère et facile à installer. Surface magnétique en liège. Porte à ouverture vertical en polycarbonate haute visibilité, idéal pour les espaces réduits. Dos en acier galvanisé. Accessoires pour le montage mural inclus. Profondeur utile 24mm. Profondeur totale 48mm.

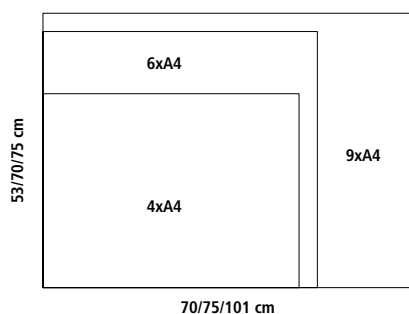

Ref.	cm (embalaje / packaging)	kg / m <sup>3</sup> (embalaje / packaging)
<b>RD-3681V17EX</b> (70x53 cm) (4xA4)	76x59x8	7,40 kg / 0,033 m <sup>3</sup>
<b>RD-3682V17EX</b> (75x70 cm) (6xA4)	81x76x8	10,70 kg / 0,046 m <sup>3</sup>
<b>RD-3683V17EX</b> (101x75 cm) (9xA4)	107x81x8	14,80 kg / 0,065 m <sup>3</sup>

# VITRINA INTERIOR / EXTERIOR INDOOR/OUTDOOR

DISPLAY CABINET • SCHAUKASTEN AUSSENBEREICH (PINNBOARD) • VITRINE

**[ESP]** Vitrina realizada en aluminio extruido, ligera y de fácil instalación con marco reforzado. Superficie tapizada. Puerta abatible de apertura vertical en policarbonato de alta visibilidad, ideal para espacios reducidos. Trasera adicional de acero cincado. Se suministra con cerradura y 2 llaves universales. Incluye accesorios para la fijación a la pared. Profundidad útil 24mm. Profundidad total 48 mm.

**[ENG]** Display cabinet made in extruded aluminium, light and easy to install, with upholstered surface. With vertical-opening doors of polycarbonate, ideal for small spaces. Zink steel extra backing. Supplied with 2 universal keys and accessories for wall fixing. Usable depth 24 mm. Total depth 48 mm.

**[DE]** Außenbereich-geeigneter Schaukasten aus stranggepresstem Aluminium Mit Aushangfläche aus blauem Stoff . Vertikal zu öffnende, transparente Kunststoffabdeckung. 2 Universalschlüssel und Zubehör für die Wandmontage im Lieferumfang enthalten. Nutztiefe 24 mm. Gesamttiefe 48 mm.

**[FR]** Vitrine réalisée en aluminium extrudé, légère et facile à installer. Surface magnétique tapissée. Porte à ouverture vertical en polycarbonate haute visibilité, idéal pour les espaces réduits. Dos en acier galvanisé. Accessoires pour le montage mural inclus. Profondeur utile 24mm. Profondeur totale 48mm.

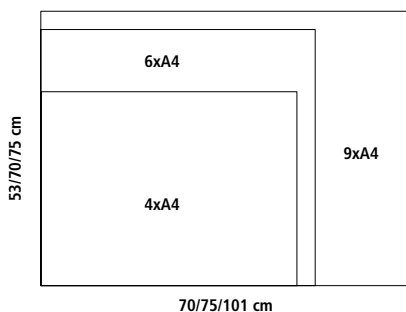

Ref.	cm (embalaje / packaging)	kg / m <sup>3</sup> (embalaje / packaging)
<b>RD-3691V17EX</b> (70x53 cm) (4xA4)	76x59x8	7,80 kg / 0,033 m <sup>3</sup>
<b>RD-3692V17EX</b> (75x70 cm) (6xA4)	81x76x8	10,70 kg / 0,046 m <sup>3</sup>
<b>RD-3693V17EX</b> (101x75 cm) (9xA4)	107x81x8	14,60 kg / 0,065 m <sup>3</sup>



# VITRINA CON SOPORTE

## DISPLAY CABINET WITH SUPPORT • SCHAUKASTEN MIT STÄNDE DISPLAY CABINET WITH SUPPORT

**[ESP]** Vitrina realizada en aluminio extruido, ligera y de fácil instalación. Superficie magnética lacada en blanco (apta para rotuladores de borrado en seco), en seco y en corcho según modelo. Puerta batiente en policarbonato de alta visibilidad. Traseira adicional de acero cincado. Se suministra con cerradura y 2 llaves universales. Profundidad útil 24mm. Profundidad total 48 mm. Soporte metálico con base de acero y pie de aluminio extruido para ser utilizado en interior y exterior.

**[ENG]** Display cabinet made in extruded aluminium, easy to install, with lacquered (dry-wipe) metal surface, metal surface and cork surface. With casement-opening doors of polycarbonate. Zinc steel extra backing. Supplied with 2 universal keys. Useful depth 24 mm. Total depth 48 mm. Metallic support made in steel base and aluminium leg to be used indoor and outdoor.

**[DE]** Schaukasten aus stranggepresstem Aluminium. Leichte Bauart, einfach zu installieren. Aushangfläche je nach Ausführung weiß lackiert und magnethaftend (geeignet für trocken abwischbare Marker), aus Kork. Helle, horizontal öffnende Kunststofftür (Polycarbonat). Rückseite aus verzinktem Stahl. Abschließbar, 2 Schlüssel im Lieferumfang enthalten. Nutztiefe 24 mm. Gesamttiefe 48 mm. Gestell mit Stahlbasis und Fuß aus stranggepresstem Aluminium, geeignet für Innen- und Außenbereiche.

**[FR]** Vitrine fabriquée en aluminium extrudé, légère et facile à installer. Surface magnétique laquée en blanc (apte pour les marqueurs effaçables à sec), ou en liège, selon modèle. Porte battante en polycarbonate de grande visibilité. Dos en acier galvanisé. Livrée avec serrure et 2 clés universelles. Profondeur utile 24 mm. Profondeur totale 48 mm. Support métallique avec base en acier et pied en aluminium extrudé, pour une utilisation à l'intérieur ou à l'extérieur.



**RD-3630-LC4**

Superficie lacada  
Lacquered surface

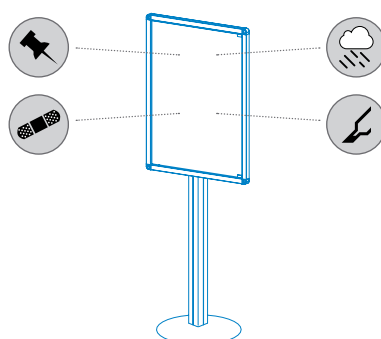
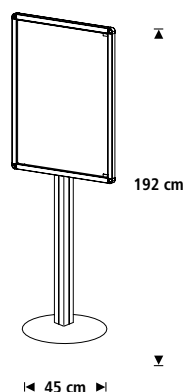

**RD-3630-CK4**

Superficie de corcho  
Cork surface

Ref.	n° (embalaje / packaging)	kg / m <sup>2</sup> (embalaje / packaging)
○ <b>RD-3630-LC4</b> (70x53) (4xA4)	3	7,90 kg / 1,933 m <sup>3</sup>
○ <b>RD-3630-LC6</b> (75x70) (6xA4)	3	11,80 kg / 1,946 m <sup>3</sup>
● <b>RD-3630-CK4</b> (70x53) (4xA4)	3	7,30 kg / 1,933 m <sup>3</sup>
● <b>RD-3630-CK6</b> (75x70) (6xA4)	3	11,80 kg / 1,946 m <sup>3</sup>

# PANTALLA DE PROYECCIÓN TRÍPODE

TRIPOD SCREEN • STATIV-LEINWAND • ÉCRAN DE PROJECTION AVEC TRÉPIED

**[ESP]** Pantalla de proyección enrollable, fabricada en tela anti-reflejante con soporte trípode fabricado en aluminio lacado. Posee un brazo para corregir la posición de la imagen. Su estructura es totalmente plegable para facilitar el transporte y almacenamiento. Viene montada.

**[ENG]** Tripod projection screen fabricated in lacquered aluminium, with antireflective fabric. Incorporates an arm for image projection correction. Totally foldable to facilitate transportation and storage. Comes mounted.

**[DE]** Leicht zusammenlegbare transportierbare Stativ-leinwand. Außenmaß Projektionsfläche 150x150 cm. Mit Keystone-Bügel. Höhe stufenlos arretierbar.

**[FR]** Écran de projection enrollable, fabriqué en toile anti-reflet, avec support trépied fabriqué en aluminium laqué. Est équipé d'un bras afin de corriger la position de l'image. Sa structure est entièrement pliable afin de faciliter le transport et le stockage. Livré monté.

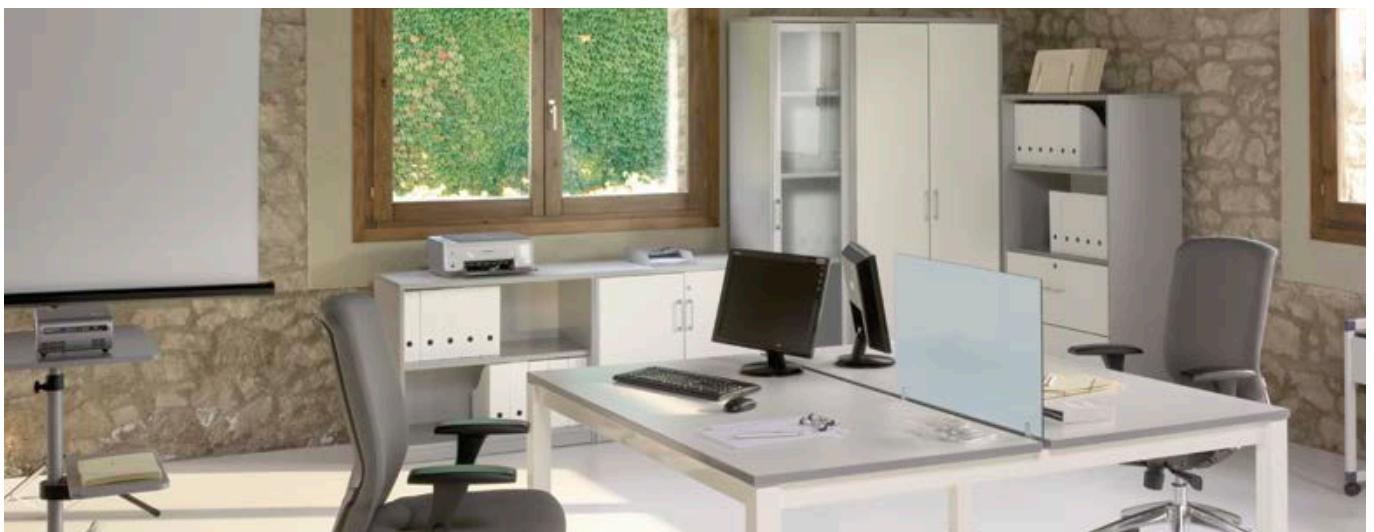
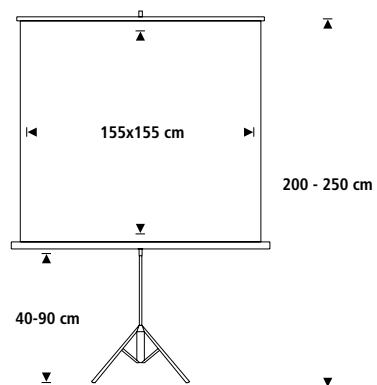

Ref.	cm (embalaje / packaging)	kg / m <sup>3</sup> (embalaje / packaging)
RD-3045	175x15x9	6 kg / 0,022 m <sup>3</sup>

# PANTALLA DE PROYECCIÓN DE PARED

WALL SCREEN • PROJEKTIONSWAND • ÉCRAN DE PROJECTION SUR MUR

**[ESP]** Pantalla de proyección enrollable mural, adaptable a techo o pared. Fabricada en tela anti-reflejante. La carcasa está fabricada en aluminio. Enrollado automático. Viene montada.

**[ENG]** Wall projection screen adaptable for wall and ceiling. Aluminium structure with antireflective fabric. The fabric can be rolled to the required size and the rolling is automatic. Comes mounted.

**[DE]** Projektionswand 190x143 (4:3) cm für Wand und Deckenmontage. Höhe stufenlos arretierbar.

**[FR]** Écran de projection enroulable et mural, s'adaptant au plafond ou au mur. Fabriqué en toile anti-reflet. Le boîtier est en aluminium. Enroulement automatique. Livré monté.

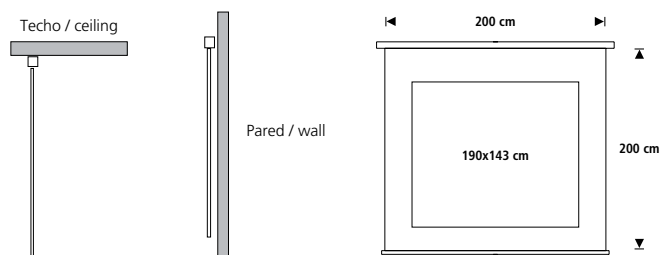

Ref.	cm (embalaje / packaging)	kg / m <sup>3</sup> (embalaje / packaging)
RD-3046	226x12x10	8,16 kg / 0,024 m <sup>3</sup>

# SOPORTE PROYECTOR PARA TECHO

CEILING PROJECTOR SUPPORT • DECKENHALTERUNG FÜR PROJEKTOR  
SUPPORT POUR PROJECTEUR AU PLAFOND

**[ESP]** Soporte proyector realizado en acero perfecto para todo tipo de proyecciones de larga y corta distancia. Viene montado. Para soportes de ultracorta distancia, consultar Rocada.

**[ENG]** Steel projector support for all types of long- and short-throw projection. Supplied assembled. For ultra short distance projectors, contact Rocada.

**[DE]** Universelle Projektor-Deckenhalterung aus Stahl, dreh- und neigbar.

**[FR]** Support de projecteur réalisé en acier et idéal pour tout type de projection à distance focale courte et longue. Livré monté.

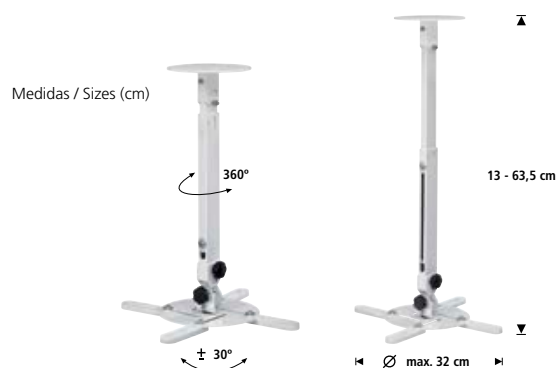

Ref.	cm (embalaje / packaging)	kg / m <sup>3</sup> (embalaje / packaging)
RD-3047	24x27x8	2,45 kg / 0,004 m <sup>3</sup>

# SEPARADOR MÓVIL

MOBILE DIVIDER • PROSPEKTSTÄNDER • CLOISON MOBILE

**[ESP]** Separador móvil multifuncional con estructura realizada en acero que permite la fijación de cinco bandejas metálicas RD-8320 por ambos lados. Estructura modular lineal o a 90°. Ruedas de serie con freno.

**[ENG]** Multifunctional mobile divider with steel structure enabling the attachment of five RD-8320 trays on both sides. Straight modular or 90° structure.

**[DE]** Mobiles Trägergestell aus pulverbeschichtetem Stahlrohrahmen für die beidseitige Aufnahme von bis zu 5 Metallablagen RD-8320. Verkettungswinkel: 90° und 180°

**[FR]** Cloison mobile multifonctions avec structure en acier permettant de fixer 5 étagères métalliques RD-8320 de chaque côté. Structure modulaire linéaire ou à 90°.



5 baldas incluidas  
5 shelves included

Medidas / Sizes (cm)

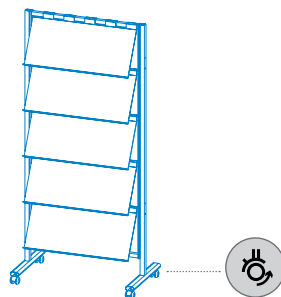
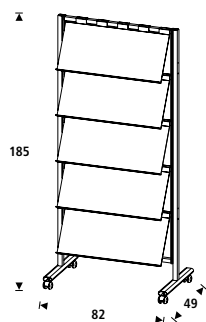

RD-8320 (5u.)

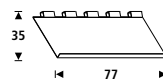

Bandejas adicionales  
Additional trays

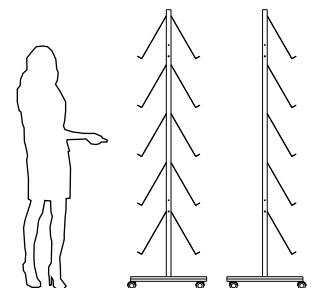

Ref.	n° (embalaje / packaging)	cm (embalaje / packaging)	kg / m³ (embalaje / packaging)
<b>RD-8304 (Complete)</b>	2	(83x192x15) + (80x39x10)	33,60 kg / 0,270 m³
<b>RD-8320 (5u.) opcional / optional</b>	1	80x39x10	5,15 kg / 0,031 m³

# REVISTERO DE PARED

MAGAZINE WALL RACK • WANDZEITUNGSHALTER • PORTE-REVUES MURALMOBILE

**[ESP]** Revistero de pared fabricado en acero. Fijación a pared mediante dos puntos. (3 unidades por caja).

**[ENG]** Steel magazine wall rack. 2 point wall attachment. (3 units per box).

**[DE]** Wandhalter für Zeitschriften. Pulverbeschichtetes Stahlblech, 2-Punkt-Befestigung.

**[FR]** Porte-revues mural en acier. Fixation murale par 2 points.



Medidas / Sizes (cm)

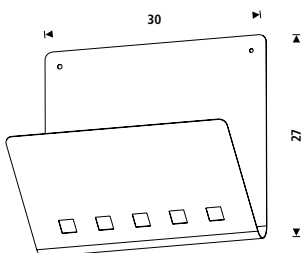

Ref.	cm (embalaje / packaging)	kg / m <sup>3</sup> (embalaje / packaging)
2980 (3 u.)	37x26x23	3,8 kg / 0,022 m <sup>3</sup>

# SEPARADOR MÓVIL

MOBILE DIVIDER • UNIVERSAL PIN-UND MODERATIONSWAND • CLOISON MOBILE

**[ESP]** Separador móvil de doble cara de estructura metálica y superficie blanda para chinchetas y notas. Gracias a su resistente superficie absorbe la sonoridad. Ruedas de serie. Permite múltiples combinaciones gracias a la ref. RD-8115.

**[ENG]** Double face mobile divider of a metallic structure and with a bland surface for pins and notes. Thanks to its resistant surface, it absorbs loudness. Allows multiple combinations thanks to the ref. RD-8115.

**[DE]** Neuartiges Pinn- und Stellwandwandkonzept mit innovativem und standfestem Rollenfußgestell sowie einem stabilem Metallrahmen. Die Fußform ermöglicht die Anordnung mehrerer Tafeln auch im 90° und 180° Winkel. Feste Verbindung mittels Zubehörset RD 8115. Die Rollen gehören zum Lieferumfang. Die Platte ist beidseitig stoffbespannt, Pinnadeln können leicht eingestochen werden.

**[FR]** Cloison mobile, structure métal et surface en revêtement spécial pour punaises et notes. Atténuation des bruits grâce au revêtement résistant. Permet de multiples combinaisons, grâce à la réf. RD-8115.

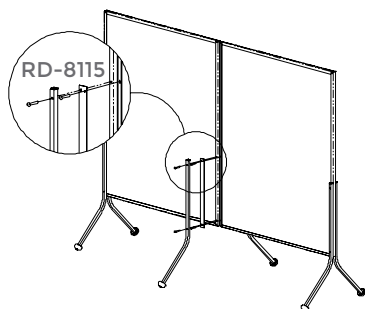

Piezas unión que permiten múltiples configuraciones.  
Joining parts that allow multiple configurations.  
Verbindungsteile, welche verschiedene Konfigurationen erlauben.  
Raccords permettant de multiples configurations.

RD-8100

RD-8100/2

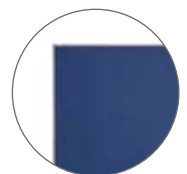
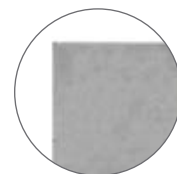

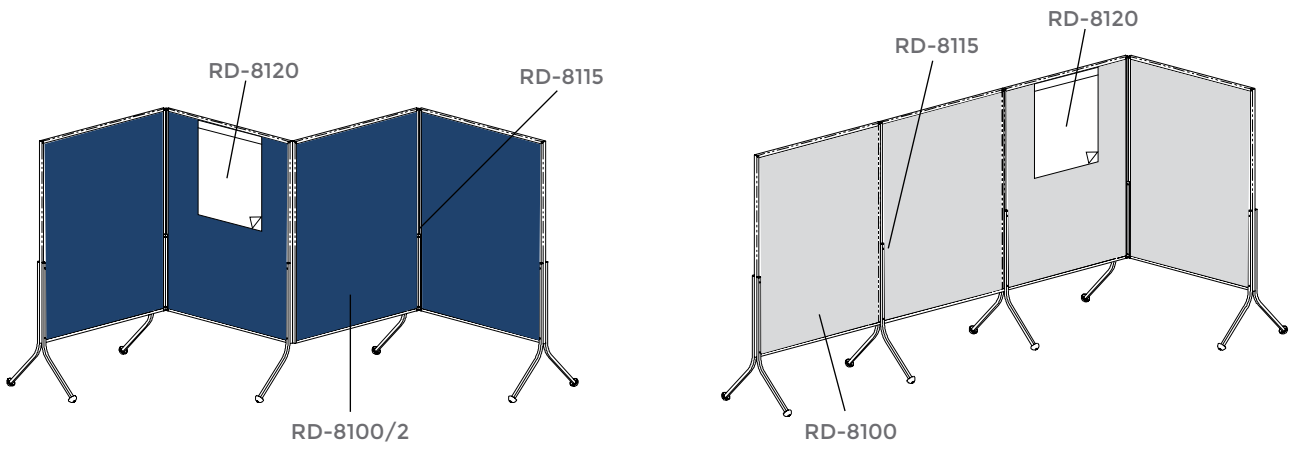

Medidas / Sizes (cm)

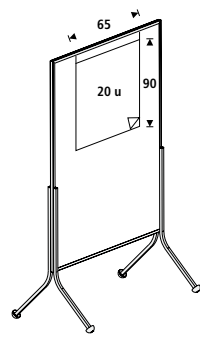
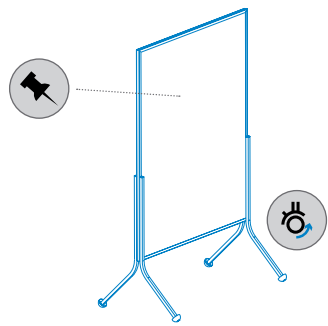
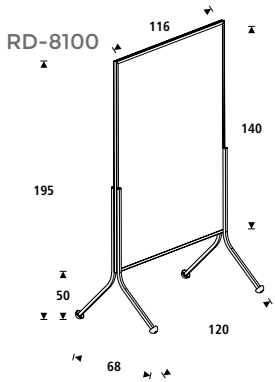

**RD-8120**  
 Bloque de papel 20 hojas 70 gr y sistema de fijación.  
 Paper block 20 sheets 70 gr and fixation system.  
 Aufsteckbare Flipchartpapier-Halterung für Block mit 20 Blatt Papier.

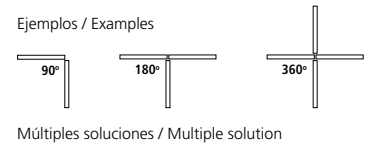

Ref.	cm (embalaje / packaging)	kg / m <sup>3</sup> (embalaje / packaging)
<b>RD-8100</b>	175x123x6	12,1 kg / 0,129 m <sup>3</sup>
<b>RD-8100/2</b>	175x123x6	12,1 kg / 0,129 m <sup>3</sup>
<b>RD-8115</b> opcional / optional	54x5x5	2 kg / 0,001 m <sup>3</sup>
<b>RD-8120</b> opcional / optional	87x8x8	1,95 kg / 0,005 m <sup>3</sup>

# PANEL INFORMATIVO

INFORMATION PANEL • INFOTAFEL • PANNEAU D'INFORMATION

**[ESP]** Panel informativo metálico de doble cara fabricado en blanco, apto para la escritura con rotulador de borrado en seco. Opcional protector de polímero técnico imantado para proteger la escritura o la fijación de información impresa. Fácil montaje.

**[ENG]** Metal information panel made in two finishes: in white, suitable for writing with dry-wipe marker, or in black for writing with chalk. Optional magnetic technical polymer protector to protect the writing or the fixing of printed information. Easy to assemble.

**[DE]** Metall-Infotafel in Weiß zum Beschreiben mit trocken abwischbaren Markern. Einfach aufzubauen.

**[FR]** Panneau d'information métallique proposé en deux finitions : blanc pour l'écriture au marqueur effaçable à sec ou noir pour l'écriture à la craie. Protecteur en polymère technique aimanté en option afin de protéger l'écriture ou la fixation de l'information imprimée. Facile à monter.



Superficie para rotuladores de borrado en seco.  
No limpiar con alcohol o productos abrasivos.  
Dry wipe surface. Never clean it with alcohol or abrasive products.  
Bitte niemals mit reinem Alkohol reinigen und keine Tücher mit abrasiven Eigenschaften verwenden.  
Surface effaçable à sec. Ne nettoyer jamais la surface avec de l'alcool ou un produit abrasif.



Admite rotulador de tiza líquida.  
Allows liquid chalk markers

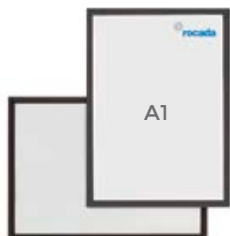

RD-S0301A1  
Optional  
Optional

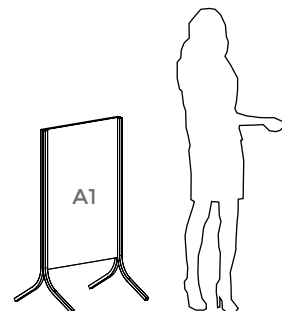

Medidas / Sizes (cm)

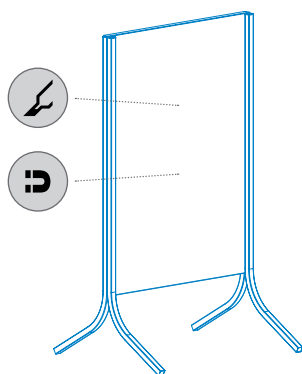
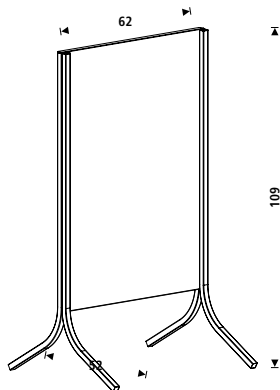

Ref.	cm (embalaje / packaging)	kg / m <sup>3</sup> (embalaje / packaging)
RD-8210 (Blanco / White)	121x67x40	5,75 kg / 0,032 m <sup>3</sup>
RD-S0301A1 (1u) opcional / optional	87x63x2	1,00 kg / 0,010 m <sup>3</sup>



# PANEL INFORMATIVO METÁLICO REGULABLE EN ALTURA

ADJUSTABLE-HEIGHT METAL INFORMATION PANEL • PLAKAT-BODENSTÄNDER • PANNEAU D'INFORMATION MÉTALLIQUE RÉGLABLE EN HAUTEUR

**[ESP]** Panel informativo metálico regulable en altura con panel rotativo 360°. Superficie metálica para fijar documentos en formato A2, A3 o A4 mediante imanes y pintada en blanco para escribir directamente con rotuladores especiales para pizarra. Fácil montaje.

**[ENG]** Adjustable-height metal information panel finished in white, suitable for writing with dry-wipe marker. Easy to assemble.

**[DE]** Höhenverstellbarer Metall-Plakatständer für den Innenbereich. Format-Varianten A2, A3, A4. Die weiße Trägerplatte kann mit Boardmarkern beschriftet werden, alternativ kann ein Papierdokument in eine magnethaftende, transparente Info-Hülle ( separat zu bestellen) eingelegt werden. Die Informationsdarstellung kann wahlweise senkrecht oder waagrecht erfolgen. Stabiles Bodengestell aus Metall.

**[FR]** Panneau d'information métallique réglable en hauteur et proposé en blanc pour l'écriture au marqueur effaçable à sec ou noir pour l'écriture à la craie. Facile à monter.

MEJORADA  
IMPROVED

NEW



Admite rotulador de tiza líquida.  
Allows liquid chalk markers

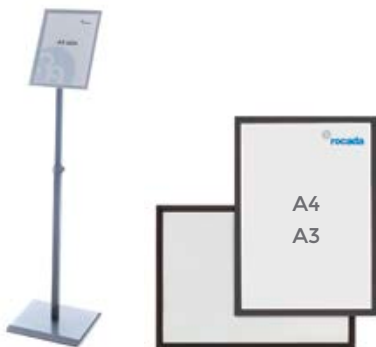
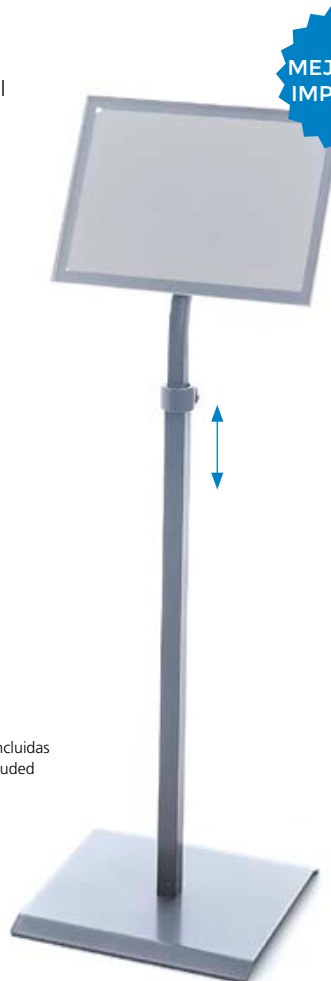

Fundas magnéticas incluidas  
Magnetic sleeves included

Medidas / Sizes (cm)

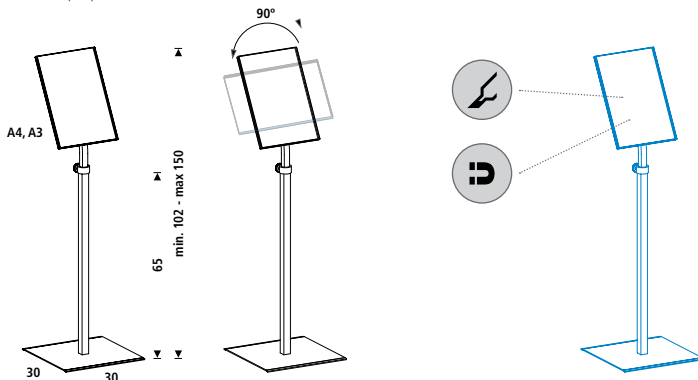

Ref.	cm (embalaje / packaging)	kg / m <sup>3</sup> (embalaje / packaging)
<b>BS07055</b> A4	80x58x5	4,9 kg / 0,024 m <sup>3</sup>
<b>BS07065</b> A3	80x58x5	5,8 kg / 0,024 m <sup>3</sup>

# PANEL INFORMATIVO INTERIOR / INDOOR

INFORMATION PANEL • KUNDENSTOPPER • PANNEAU D'INFORMATION

**[ESP]** Panel informativo tipo Aboard para tiza o rotulador de tiza líquida. Estructura plegable realizada en madera natural acabado color cerezo. Superficie de escritura de color negro en ambas caras. Ideal para restaurantes, bares y comercios en general.

**[ENG]** A-board informative panel for writing with chalk. Folding structure made in natural wood with cherry colour finish which allows writing on both sides. Black writing surface. Ideal for restaurants, bars and businesses in general.

**[DE]** Schwarze Schreibfläche, beidseitig mit Kreide feuch abwischbar zu beschreiben. Dekoratives, klappbares Gestell aus Naturholz, Kirschholzfarben lackiert. Ideal für Restaurants, Bars, Cafés...

**[FR]** Panneau d'information type Aboard pour craie. Structure pliante réalisée en bois naturel finition couleur cerise pour écriture sur les deux faces. Surface d'écriture de couleur noire Idéal pour restaurants, bars, commerces en général.



Admite rotulador de tiza líquida  
Allow liquid chalk marker



Medidas / Sizes (cm)

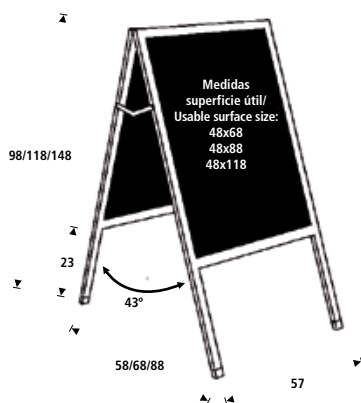

Ref.	cm (embalaje / packaging)	kg / m <sup>3</sup> (embalaje / packaging)
<b>BSA2CH</b> (50x70 cm)	92x66x11	4,80 kg / 0,067 m <sup>3</sup>
<b>BSA1CH</b> (50x90 cm)	122x66x11	5,80 kg / 0,089 m <sup>3</sup>
<b>BSA0CH</b> (50x120 cm)	152x96x11	10,80 kg / 0,161 m <sup>3</sup>

# PANEL INFORMATIVO INTERIOR / INDOOR

INFORMATIVE PANEL • KREIDE-WANDTAFEL • PANNEAU

**[ESP]** Panel informativo de pared para tiza o rotulador de tiza líquida. Estructura realizada en madera natural con acabado en color cerezo. Superficie de escritura de color negro ideal para restaurantes, bares y comercios en general.

**[ENG]** Informative wall panel for writing with chalk. Structure made in natural wood with cherry colour finish. Black writing surface. Ideal for restaurants, bars and businesses in general.

**[DE]** Dekorative Wandtafel mit Naturholz-Rahmen, Kirschholzfärbung lackiert. Mit Kreide feucht abwischbar zu beschreiben. Ideal für Restaurants, Bars, Cafés...

**[FR]** Panneau mural d'information pour craie. Structure réalisée en bois naturel finition couleur cerise. Surface d'écriture de couleur noire. Idéal pour restaurants, bars, commerces en général.

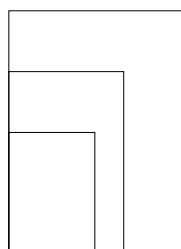

60/90/120 cm

45/60/90 cm



Admite rotulador de tiza líquida  
Allow liquid chalk marker

Ref.	cm (embalaje / packaging)	kg / m <sup>3</sup> (embalaje / packaging)
<b>BS0720</b> (60x45 cm)	72x47x3	2,20 kg / 0,008 m <sup>3</sup>
<b>BS0721</b> (90x60 cm)	103x62x3	3,95 kg / 0,016 m <sup>3</sup>
<b>BS0722</b> (120x90 cm)	133x92x3	7,20 kg / 0,031 m <sup>3</sup>

# INFORMACIÓN EXTERIOR / OUTDOOR

## INFORMATION • INFORMATION • INFORMATION

**[ESP]** Marcos informativos clip. Cuélguelos en todas las paredes y pasillos de más rotación. Informe y capte clientes nuevos con sus ofertas más sensacionales. Gracias a su sistema clip, permite cambiar la publicidad de forma muy rápida. Marco de aluminio anodizado en plata de limpieza fácil y codos de plástico decorativos. Viene montado.

**[ENG]** Aluminium snap frames. Hang them up on all (the out) walls and corridors where the majority of the people pass through. Inform the clients and capture new clients with your most sensational offers. Thanks to its clip system, it allows you to rapidly change publicity. Easy cleaning silver anodized aluminium frame with decorative plastic corners. Comes assembled.

**[DE]** Bilderwechselrahmen. Diese dekorativen „Flachvittrinen“ ermöglichen aufgrund des Klapprahmenprinzips ein einfaches und schnelles Wechseln der Aushänge. Silbereloxiertes Aluminiumprofil, stabile Polystyrol-Rückwand und Antireflex-Schutzfolie. Nur für Wandmontage geeignet.

**[FR]** Cadre clip mural en aluminium. Informez les clients et captez l'attention de nouveaux clients avec vos informations importantes. Grâce au système clip, permet de changer l'information rapidement. Cadre aluminium anodisé argent. Entretien facile, coins décoratifs en plastique.

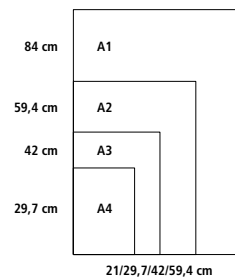

Ref.	cm (embalaje / packaging)	kg / m <sup>3</sup> (embalaje / packaging)
<b>BS0701</b> (DINA4 21x29,7 cm)	34x25x2	0,5 kg / 0,002 m <sup>3</sup>
<b>BS0702</b> (DINA3 29,7x42 cm)	46x34x2	0,7 kg / 0,003 m <sup>3</sup>
<b>BS0703</b> (DINA2 42x59,4 cm)	64x46x2	1,45 kg / 0,005 m <sup>3</sup>
<b>BS0704</b> (DINA1 59,4x84 cm)	101x64x3	2,75 kg / 0,016 m <sup>3</sup>

# POSTE DE CINTA RETRÁCTIL

RETRACTABLE QUEUE GUIDES • METALLISCHER ABSPERRPFOSTEN  
 POTEAU GUIDE-FILES A SANGLE RÉTRACTILE

**[ESP]** Poste metálico con 2m de cinta flexible acabado en negro. Las cintas se pueden personalizar bajo pedido.

**[ENG]** Freestanding solutions with 2m flexi belts in black finish. The belts can be branded with logos or messages as required.

**[DE]** Selbstspannender Absperrständer mit Gurtsystem. Verfügbar in verschiedenen Farben. Auf Wunsch können die Gurte mit Ihrem Logo bedruckt werden.

**[FR]** Barrière tendue avec la ceinture flexible en noir. Les ceintures peuvent être marqués selon vos souhaits.



Para colores especiales consultar Rocada.  
 For special colours contact Rocada.

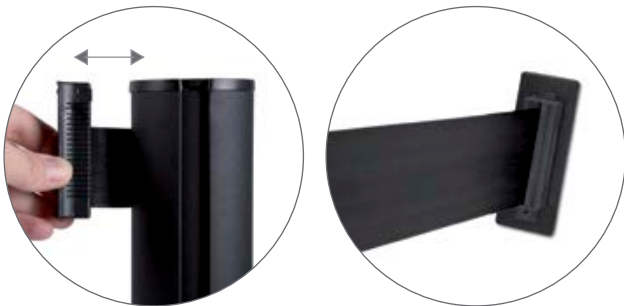

Medidas / Sizes (cm)

BS077=S

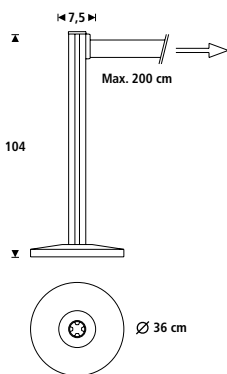

BS0771S

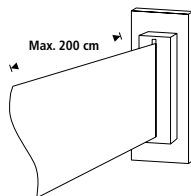

BS0771S

Terminal de pared opcional  
 Optional wall terminal



Ref.	cm (embalaje / packaging)	kg / m <sup>3</sup> (embalaje / packaging)
<b>BS0770S</b> (2u.)	105x55x12	23 kg / 0,069 m <sup>3</sup>
<b>BS0771S</b> opcional / optional	10x10x10	0,1 kg / 0,001 m <sup>3</sup>

# EXPOSITORES

## DISPLAY SYSTEMS • PROSPEKTSTÄNDER • PRÉSENTOIRS

**[ESP]** Expositores de sobremesa de metacrilato para tamaño DIN A3, A4, A5 y 1/3 de A4 con diferentes funciones para transmitir la información adecuada a cada necesidad.

**[ENG]** Plexiglas tabletop display systems for sizes DIN A3, A4, A5 and 1/3 A4 with various functions for transmitting the right information when necessary.

**[DE]** Infoständer aus Methacrylat, für unterschiedliche Papierformate erhältlich.

**[FR]** Présentoirs de table en méthacrylate pour dimension DIN A3, A4, A5 et 1/3 de A4 avec différentes fonctions pour apporter l'information adaptée à chaque besoin.



**RD-3813**  
Portatarjetas individual  
Individual card holders  
Visitenkartenhalter (Einzelformat)  
Porte carte individuel

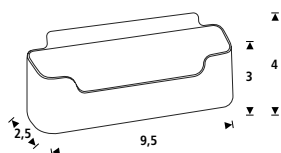

Modelo forma L  
L form model



Modelo forma T  
T form model

Medidas / Sizes (cm)

Modelo forma L / L form model

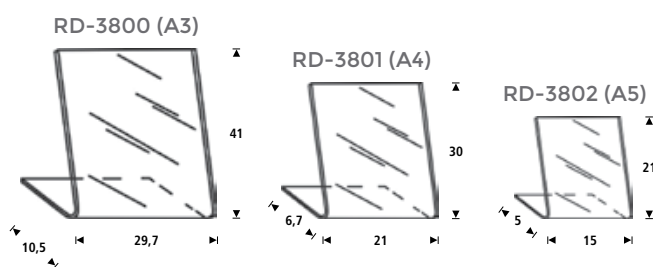

Modelo forma T / T form model

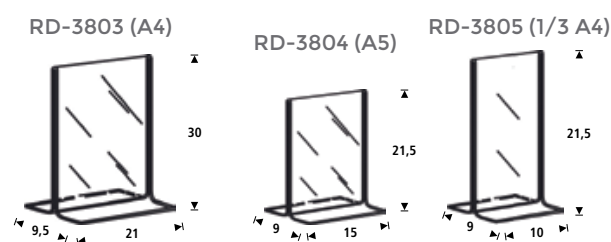

Ref.	u.	cm (embalaje / packaging)	kg / m <sup>3</sup> (embalaje / packaging)
<b>RD-3800 (A3)</b>	Caja 6 u. / Box 6 u.	48x16x33	5 kg / 0,024 m <sup>3</sup>
<b>RD-3801 (A4)</b>	Caja 12 u. / Box 12 u.	39x12x24	3,1 kg / 0,011 m <sup>3</sup>
<b>RD-3802 (A5)</b>	Caja 12 u. / Box 12 u.	30x11x18	1,6 kg / 0,005 m <sup>3</sup>
<b>RD-3803 (A4)</b>	Caja 12 u. / Box 12 u.	41x35x25	3,7 kg / 0,035 m <sup>3</sup>
<b>RD-3804 (A5)</b>	Caja 12 u. / Box 12 u.	38x25x18	2 kg / 0,016 m <sup>3</sup>
<b>RD-3805 (1/3 A4)</b>	Caja 12 u. / Box 12 u.	37x25x13	1,4 kg / 0,011 m <sup>3</sup>
<b>RD-3813</b>	Caja 24 u. / Box 24 u.	23x11x24	0,8 kg / 0,004 m <sup>3</sup>

# EXPOSITORES

## DISPLAY SYSTEMS • PROSPEKTSTÄNDER • PRÉSENTOIRS

**[ESP]** Expositores de sobremesa o pared de metacrilato para tamaño A4, A5 y 1/3 de A4 con diferentes funciones para transmitir la información adecuada a cada necesidad.

**[ENG]** Plexiglas tabletop or wall display systems for sizes A4, A5 and 1/3 A4 with various functions for transmitting the right information when necessary.

**[DE]** Prospektständer aus Methacrylat, für unterschiedliche Formate erhältlich

**[FR]** Présentoirs de table en méthacrylate pour dimension A4, A5 et 1/3 de A4 avec différentes fonctions pour apporter l'information adaptée à chaque besoin.



Medidas / Sizes (cm)

RD-3806 (A4)

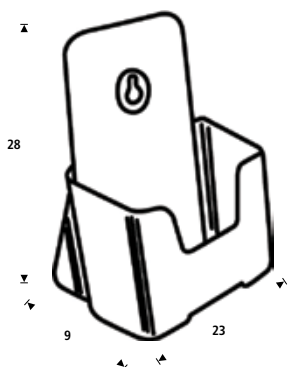

RD-3807 (A5)

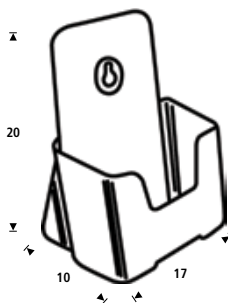

RD-3808 (1/3 A4)

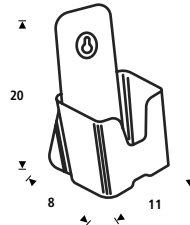

Ref.	u.	cm (embalaje / packaging)	kg / m <sup>3</sup> (embalaje / packaging)
RD-3806 (A4)	Caja 7 u. / Box 7 u.	41x26x30	2,4 kg / 0,031 m <sup>3</sup>
RD-3807 (A5)	Caja 8 u. / Box 8 u.	36x25x22	1,7 kg / 0,018 m <sup>3</sup>
RD-3808 (1/3 A4)	Caja 18 u. / Box 18 u.	36x28x22	2,3 kg / 0,021 m <sup>3</sup>

# SOPORTE DE SOBREMESA PARA PANTALLA PLANA

DESK SUPPORT FOR FLAT SCREEN • MONITORHALTER  
SUPPORT SUR TABLE POUR ÉCRAN PLAT

**[ESP]** Soporte monitor de acero de sobremesa con movimiento de rotación 90° y de giro completo 360° para pantallas LCD-TFT 14"-22". Viene montado.

**[ENG]** Aluminium support with inclination movement, rotating, which permits adaptation for screen of 10" to 24". Comes mounted.

**[DE]** Monitorhalter für den Schreibtisch. Schwenkbar. Rotation 90 ° und volle Drehung 360 ° für LCD-Flachbildschirme-/TFT 14 "- 22 ". Es ist montiert.

**[FR]** Support d'ordinateur en acier, avec inclinaison à 90 ° et rotation complète à 360 ° pour écran 14 à 22 pouces LCD-TFT. Livré

NEW

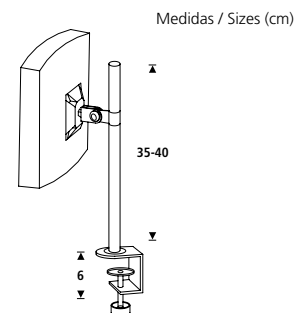
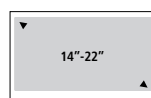
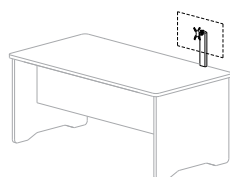

Ref.	cm (embalaje / packaging)	kg / m³ (embalaje / packaging)
RD-2025	51x15x12	1,73 kg / 0,009 m³

Hasta fin de existencias / Until stock runs out



# SOPORTE DE PARED PARA PANTALLA PLANA

WALL SUPPORT FOR FLAT SCREEN • MONITORHALTER  
SUPPORT MURAL POUR ÉCRAN PLAT

**[ESP]** Soporte de aluminio para pared con movimiento de inclinación, giro, panorámica y extensión; permite adaptar pantallas de 10" a 47". Viene montado.

**[ENG]** Aluminium support with inclination movement, rotating panoramic and extendible which permits adaptation for screen of 10" to 47". Comes mounted.

**[DE]** Monitorhalterung für die Wandmontage. Schwenkbar. Für Flachbildschirme von 10 bis 47 Zoll.

**[FR]** Support mural en aluminium avec mouvement d'inclinaison, rotation, vision panoramique et extension, s'adaptant aux écrans de 10" à 47". Livré monté.



Medidas / Sizes (cm)

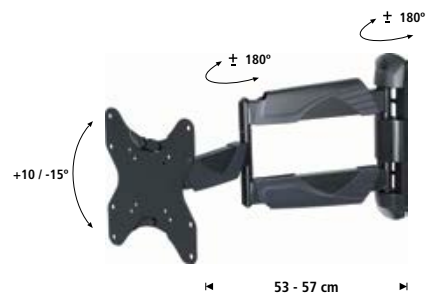
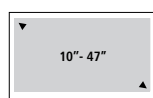
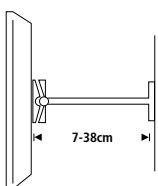

Ref.	cm (embalaje / packaging)	kg / m <sup>3</sup> (embalaje / packaging)
RD-2026	36x27x6	3,45 kg / 0.005 m <sup>3</sup>

# HOT DESK

**[ESP]** Mueble multifuncional realizado en melamina de 19mm, diseñado para dar solución a las nuevas necesidades en los puestos de trabajo móviles. Este nuevo concepto de mueble permite tener un puesto de trabajo móvil y completo, en el que se puede almacenar y transportar todo lo que uno necesita para el trabajo diario. Equipado con baldas y cajones según modelo, bandeja extraíble para elementos informáticos, paso de cables, portaetiquetas y puerta metálica con cerradura. Bandeja superior abatible 15°. Para videoproyecciones / presentaciones.

**[ENG]** Multifunctional unit made in 19 mm melamine designed to satisfy the new needs in workstations. This new concept unit makes it possible to have a complete mobile workstation for storing and transporting everything needed for everyday work. Equipped with shelves and drawers, according to the model, pull-out tray for IT devices, cable passage and metal door with lock. Flip cover 15°. For presentation use.

**[DE]** Multifunktionsmöbel für Mitarbeiter mit flexibler Arbeitsplatznutzung. Der Caddy ermöglicht die individuelle, geordnete Ablage und den Transport aller für die tägliche Arbeit erforderlichen Gegenstände und Unterlagen. Je nach Modell mit Regalen ( basic ) oder Schublade/Hängeregisterauszug. Kabeldurchführung für Strom- und Netzkabel. Ausziehbare Arbeitsplatte in 72cm Höhe. Abschließbare Metalltür mit 270° Öffnungswinkel. Große, stabile Laufrollen.

**[FR]** Meuble multifonctionnel réalisé en mélaminé de 19mm conçu pour répondre aux nouveaux besoins sur les postes de travail. Ce nouveau concept de meuble permet de disposer d'un poste de travail mobile, complet où garder et transporter tout ce qui est nécessaire pour le travail quotidien Muni d'étagères et de tiroirs selon le modèle, plateau amovible pour éléments informatiques, passage de câbles et porte métallique avec serrure.



RD-4037



RD-4036

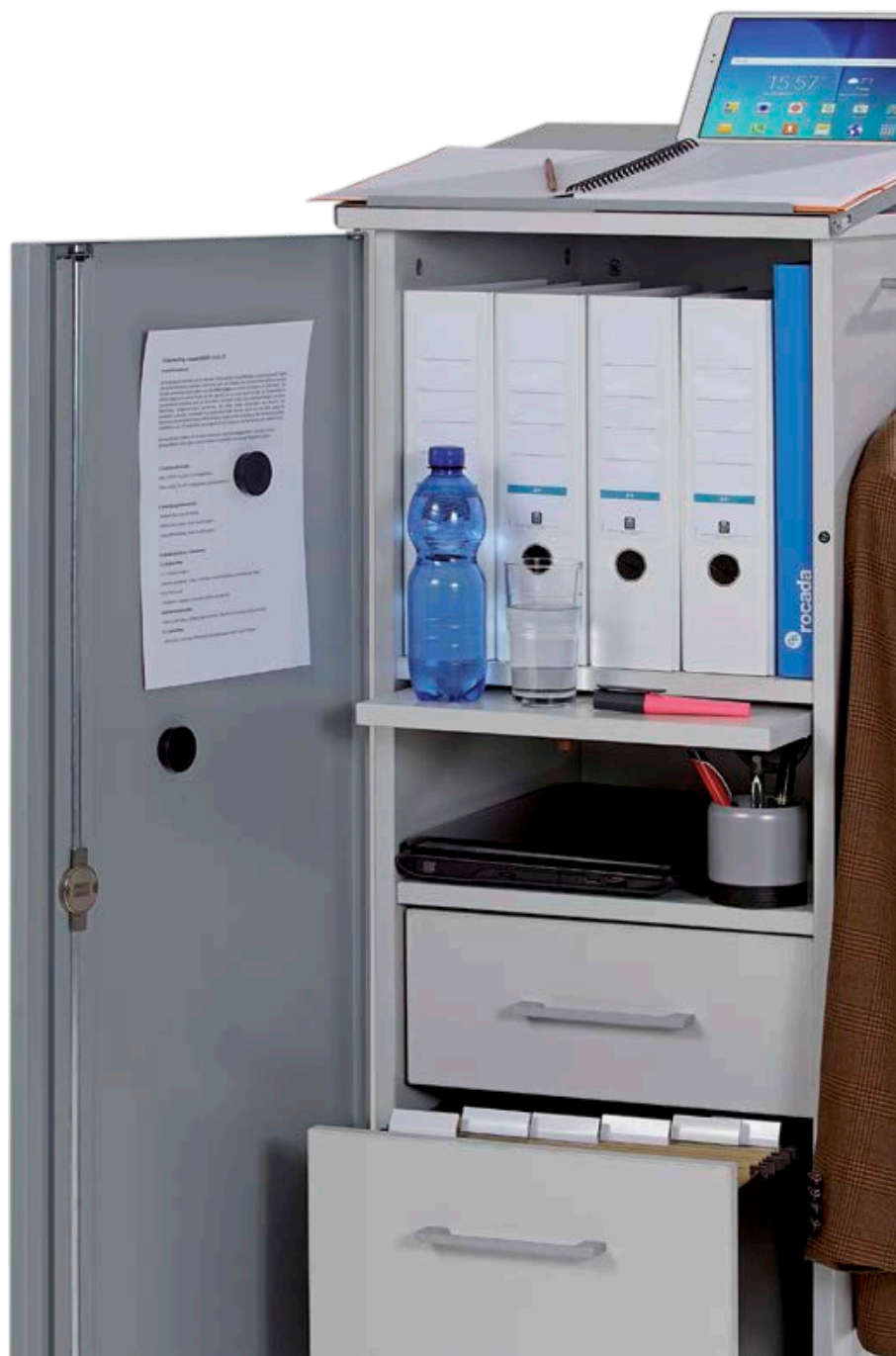



**RD-4038**

accesorio carpetas 31cm  
Accessory folder 31cm length (USA)

Medidas / Sizes (cm)

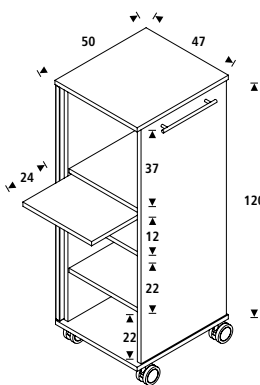

**RD-4036**

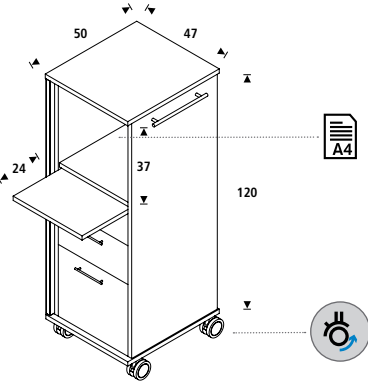

**RD-4037**

**RD-4036/1**  
**RD-4037/1**

Vista trasera / Back side

Tapa abatible 15°  
Flip cover 15°

Vista lateral / Lateral side



Puerta de metal con cerradura  
Metal door with lock

Ref.	cm (embalaje / packaging)	kg / m <sup>3</sup> (embalaje / packaging)
<b>RD-4036</b>	112x51x46	43,7 kg / 0,262 m <sup>3</sup>
<b>RD-4036/1</b>	112x51x46	43,7 kg / 0,262 m <sup>3</sup>
<b>RD-4037</b>	112x51x46	48,7 kg / 0,262 m <sup>3</sup>
<b>RD-4037/1</b>	112x51x46	48,7 kg / 0,262 m <sup>3</sup>
<b>RD-4038</b> Accesorio carpeta / file accessory (USA)	42x3x3	1kg / 0.001 m <sup>3</sup>

Desmontado bajo pedido / Knock-down on request

# CARRO MULTIFUNCIONAL

MULTIFUNCTIONAL TROLLEY • OFFICE BUTLER • CHARIOT MULTIFONCTIONS

**[ESP]** Carro multifuncional realizado en melamina de 19mm y en acero pintado. Apto para servicios de almacenamiento, catering, audiovisuales... Sus paneles laterales aumentan la privacidad deseada. Ruedas de altas prestaciones. Fácil montaje.

**[ENG]** Multifunctional trolley made of 19 mm melamine and painted steel. Suitable for storage, catering, audiovisual presentations... Its side panels allow increased privacy. High performance wheels. Easy to assemble.

**[DE]** Mobiler Mehrzweck-Trolley für Büro und Konferenzraum. Stabiles Stahlrohrgestell mit 3 melaminbeschichteten Ablageflächen (19mm). Die Position der Seitenabdeckungen kann frei gewählt werden. Verwendbar u.a. als Aktenwagen, Cateringmöbel, Gerätewagen, Beistellmöbel...

**[FR]** Chariot multifonctions en mélaminé 19 mm et acier peint. Adapté pour réaliser les tâches de stockage, catering, audiovisuel,... Ses panneaux latéraux offre une plus grande confidentialité. Roues hautes performances. Montage facile.



Medidas / Sizes (cm)

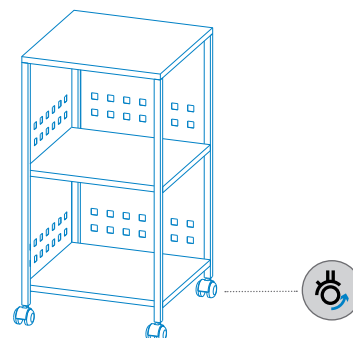
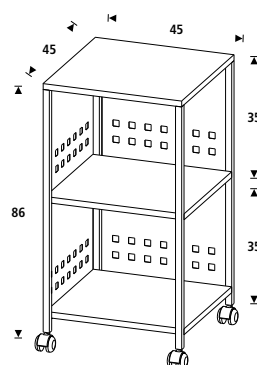

Ref.	cm (embalaje / packaging)	kg / m <sup>3</sup> (embalaje / packaging)
RD-4035	86x47x10	17 kg / 0,037 m <sup>3</sup>

# CARROS CARPETEROS

FILE TROLLEYS • HÄNGEREGISTERWAGEN • CHARIOT POUR DOSSIERS SUSPENDUS

**[ESP]** Carro carpetero móvil metálico de 2 niveles. 40 carpetas por nivel. Fácil montaje.

**[ENG]** Mobile metallic 2-level file trolley. 40 files per level. Easy assembly.

**[DE]** Einfacher, mobiler 2-stufiger Metallwagen für Hängemappen. Bis zu 40 Mappen pro Stufe.

**[FR]** Chariot pour dossiers suspendus, mobile, en métal, 2 niveaux. 40 dossiers par niveau. Facile à monter.



Medidas / Sizes (cm)

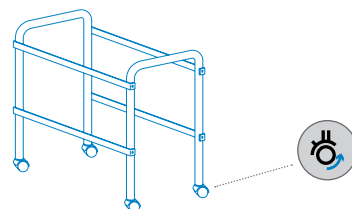
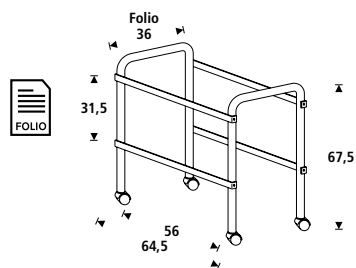

Ref.	cm (embalaje / packaging)	kg / m <sup>3</sup> (embalaje / packaging)
RD-300	68x42x5	3,3 kg / 0,014 m <sup>3</sup>

# CARROS CARPETEROS

FILE TROLLEYS • HÄNGEREGISTERWAGEN • CHARIOT POUR DOSSIERS SUSPENDUS

**[ESP]** Carro carpetero móvil metálico regulable. 45 carpetas. Fácil montaje.

**[DE]** Mobiler, praktischer Metallwagen für ca. 45 Hängemappen.

**[ENG]** Mobile adjustable metallic file trolley. 45 files. Easy assembly.

**[FR]** Chariot pour dossiers suspendus, mobile, en métal, réglable. Pour 45 dossiers. Facile à monter.



Medidas / Sizes (cm)

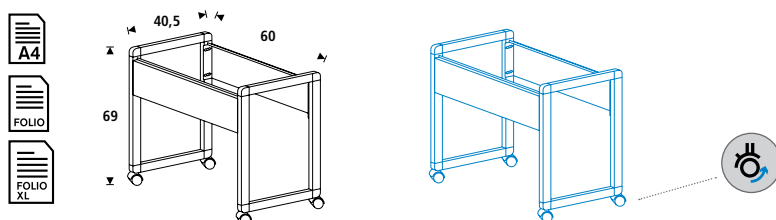

Ref.	cm (embalaje / packaging)	kg / m <sup>3</sup> (embalaje / packaging)
RD-310	68x43x11	8,3 kg / 0,032 m <sup>3</sup>

# ATRILES LECTERN LUXE

## STANDS • STATIVE • SUPPORTS

**[ESP]** Atril para presentaciones móvil de estructura cromada y curvada superficie de metacrilato de gran diseño. Regulación de las 2 bandejas en altura mediante muelles. Fácil montaje.

**[ENG]** Stand for mobile presentation, with a chrome structure and a curved, specially designed methacrylate surface. Height adjustment of the 2 shelves through springs. Easy assembly.

**[DE]** Mobiles Renderpult mit verchromten Gestell. Gebogene Frontplatte aus hochwertigem, halbtransparenten Methacrylat. Höhenverstellung mittels Federmechanik. Untere Glasplatte individuell einstellbar. Leichte Montage.

**[FR]** Pupitre de conférence mobile, structure chromée et galbée, avec panneau de décoration en méthacrylate. Réglage en hauteur à l'aide de ressorts. Facile à monter.



Cristal templado de 8mm de espesor  
Tempered glass of 8mm thickness

Personalización opcional  
Optional customization



Preparado para micrófono  
Prepared for microphone

Micro no incluido  
Microphone not included

Medidas / Sizes (cm)

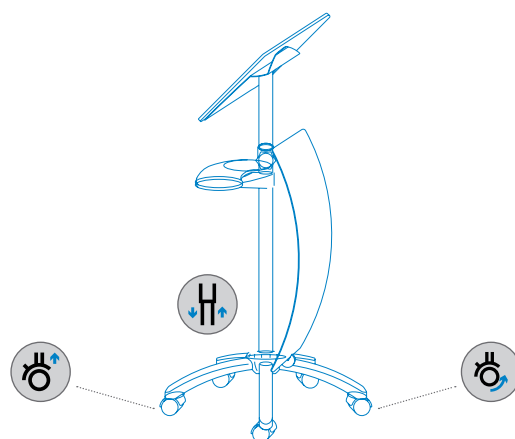
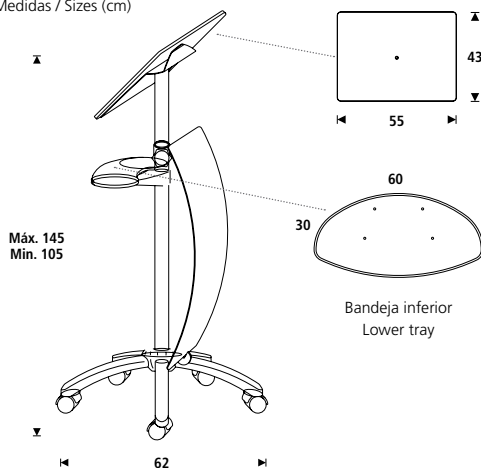

Ref.	cm (embalaje / packaging)	kg / m <sup>3</sup> (embalaje / packaging)
RD-3070	90x62x18	15 kg / 0,097 m <sup>3</sup>

# ATRILES LECTERN ECO

STANDS • STATIVE • SUPPORTS

**[ESP]** Atril para presentaciones móvil de estructura metálica. Regulación de altura mediante muelle. Fácil montaje.

**[ENG]** Stand for mobile presentations with a metallic structure. Height adjustment through springs. Easy assembly.

**[DE]** Praktisches Rednerstativ mit Metallstruktur. Höhenverstellung mittels Federmechanik. Leichte Montage.

**[FR]** Pupitre de conférence mobile, structure métal. Réglage en hauteur à l'aide de ressort. Facile à monter.



Ruedas a presión  
Click system castors

Medidas / Sizes (cm)

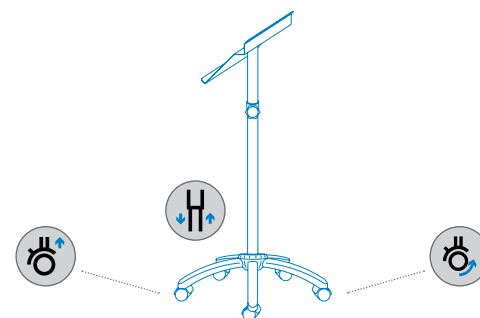
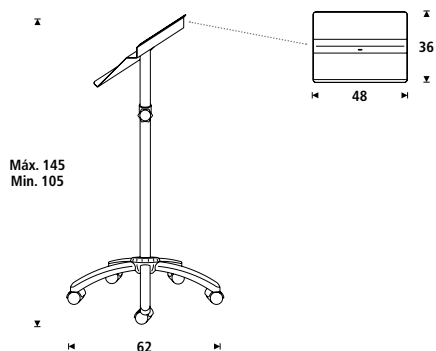

Ref.	cm (embalaje / packaging)	kg / m <sup>3</sup> (embalaje / packaging)
RD-3080	90x62x18	9,5 kg / 0,07 m <sup>3</sup>



# ACCESORIOS

## ACCESSORIES • COMPUTER - UND KLEINMÖBEL • ACCESSOIRES

**[ESP]** Mesas móviles de melamina. Perfectas para fotocopiadoras y accesorios de gran formato. Incluye puerta metálica y ruedas de diseño. Fácil montaje.

**[ENG]** Mobile melamine tables. Perfect for photocopiers and big format accessories. Includes a metallic door and specially designed castors. Easy assembly.

**[DE]** Mobile Druckertische. Auch perfekt geeignet für Fotokopierer, Faxgeräte. Viel Platz für Druckerzubehör. Mit Metalltür und speziellen Doppelaufrollen, belastbar bis 100 Kg. Leichte Montage.

**[FR]** Meubles mobiles en mélaminé, idéales pour copieur et accessoires de grand format. Porte métallique et roulettes. Facile à monter.



RD-4030

RD-4020



Acabado en haya, bajo pedido  
Finished in beech, on request

Medidas / Sizes (cm)

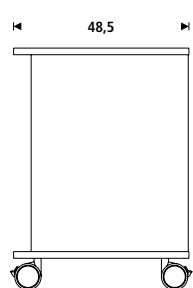

RD-4030

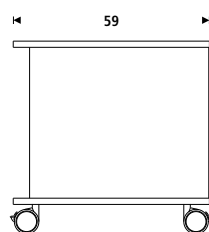
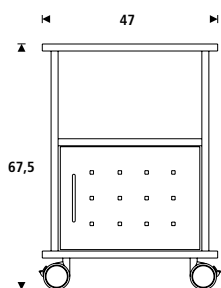

RD-4020

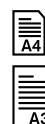
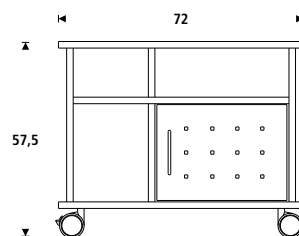

Ref.	cm (embalaje / packaging)	kg / m <sup>3</sup> (embalaje / packaging)
RD-4030	61x54x21	20,95 kg / 0,069 m <sup>3</sup>
RD-4020	84x18x62	33 kg / 0,090 m <sup>3</sup>

# MESA DE TRABAJO ERGONÓMICA MILAGRO ADJUST

ERGONOMIC WORK DESKS • ERGONOMISCHE ARBEITSTISCHE  
TABLES DE TRAVAIL ERGONOMIQUES

**[ESP]** Mesa de trabajo ergonómica móvil con diferentes regulaciones para ayudar de una forma activa en la realización de todo tipo de trabajos consiguiendo la postura deseada en cada momento. Estructura metálica regulable en altura mediante muelles que permite trabajar sentado y de pie o alternar dichas posturas. Regulable en inclinación (80°) mediante sistema de rotación CLICK de fácil activación único en el mercado. El tablero de melamina de 25mm dispone también de una bandeja retráctil para sustentar los objetos de sobremesa si es necesario o esconderla cuando no lo sea. Dispone de cajón inferior para almacenar diferentes objetos personales. El diseño de la estructura permite utilizar la zona inferior lateral para bandeja de 30cm de ancho. Ruedas de alta resistencia con sistema de frenado. Fácil montaje.

**[ENG]** Mobile ergonomic work desk with different adjustments for any type of work, offering the optimum configuration at any given time. Metal table with height adjustable by springs, to work either sitting or standing or change from one to the other. Tilting table (80°) with an easy action CLICK rotation system, unique in the market. The melamine top also has a retractable tray. Lower drawer to store different personal objects. Tray 30cm wide. Tough wheels with a braking system. Easy to assemble.

**[DE]** Ein vielseitig verwendbarer Ergänzungstisch für Produktion, Lager, Büro, Konferenzraum und Home Office. Die Höhenverstellung von 74-114 cm ermöglicht sitzende und stehende Tätigkeiten, die Ausschnittform des Fußgestells bietet reichlich Beinfreiheit. Die Tischplatte ist neigbar, unterhalb der Platte befindet sich ein seitlich ausziehbares Utensilienfach. Die stabile Bodenplatte ist 30cm tief und kann als Ablagefläche für einen Drucker oder PC genutzt werden.

**[FR]** Table de travail ergonomique nomade, avec différents réglages pour rendre plus actif et dynamique tout type de travail et trouver la position souhaitée à tout moment. Table dotée d'une structure métallique, réglable en hauteur grâce aux ressorts qui permettent de travailler assis ou debout, ou bien d'alterner les deux positions. Table avec une inclinaison réglable (80°) par système de rotation CLICK, facile à activer et unique sur le marché. Le dessus en mélamine est équipé d'une tablette rétractable. tiroir inférieur pour ranger les objets personnels. Plateau de 30 cm de large. Roulettes très résistantes et équipées d'un système de freinage. Facile à monter.

NEW



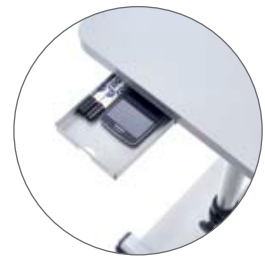

RD-3055/1  
Acabado en haya  
Finished in beech

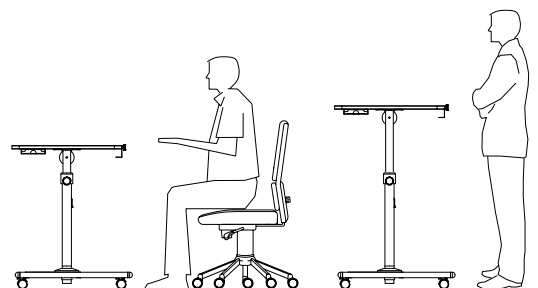
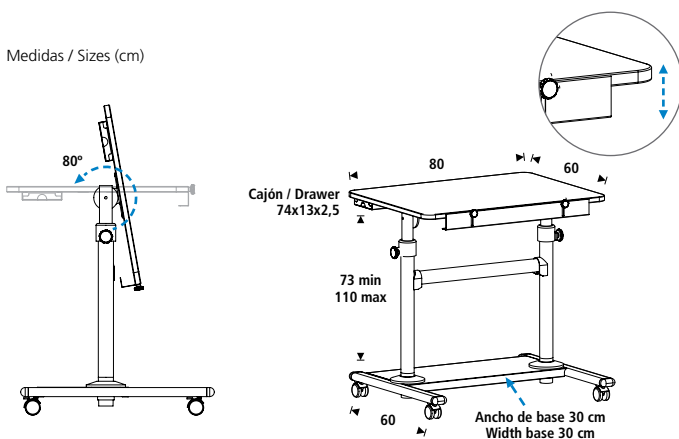

Cajón lateral derecha e izquierda de 74cm para para accesorios  
Lateral right and left drawer to store the accessories

Medidas / Sizes (cm)



Ref.	cm (embalaje / packaging)	kg / m <sup>3</sup> (embalaje / packaging)	Acabados / Finishes
RD-3055	88x69x17	27 kg / 0.103 m <sup>3</sup>	Plata - Silver / Aluminio · Aluminium 
RD-3055/1	88x69x17	27 kg / 0.103 m <sup>3</sup>	Plata - Silver / Haya · Beech 

# MESAS ORDENADOR MILAGRO

COMPUTER TABLE • COMPUTER - UND KLEINMÖBEL • POSTES INFORMATIQUE

**[ESP]** Mesa de trabajo móvil regulable en altura mediante muelles. 2 bandejas de melamina regulables en altura que permiten una rotación de 360°. Estructura metálica. Perfecta para trabajar de pie o sentado para adaptarse a las diferentes necesidades actuales de trabajo.

**[ENG]** Mobile metallic working table with 2 height adjustable melamine shelves. Height adjustment through a spring. Perfect for working either in standing or a sitting position allows to work according today's new working position.

**[DE]** Universal Stehpult für Arbeiten im Sitzen und Stehen. Stabiles Metallstativ mit feststellbaren Laufrollen. Untere Arbeitsplatte höhenverstellbar. Obere Platte bis 15 Kg, untere bis 5 Kg dauerhaft belastbar.

**[FR]** Poste de travail mobile avec les 2 plateaux réglables en hauteur. Structure métal. Parfaite pour travailler assis ou debout. Facile à monter.



Medidas / Sizes (cm)

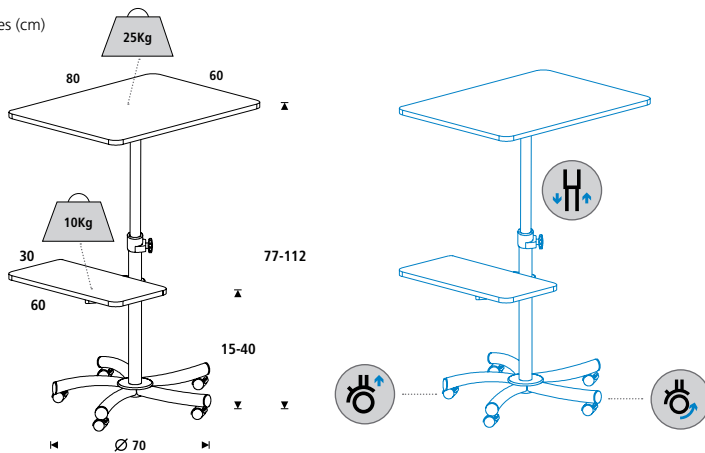

Ref.	cm (embalaje / packaging)	kg / m <sup>3</sup> (embalaje / packaging)
RD-3050	83x69x18	18 kg / 0,100 m <sup>3</sup>
RD-3050/1	83x69x18	18 kg / 0,100 m <sup>3</sup>

# MESAS ORDENADOR

COMPUTER TABLE • COMPUTER TISCHE • POSTES INFORMATIQUE

**[ESP]** Mesa ordenador móvil de estructura metálica y embellecedores de plástico, así como el reposamuñecas de diseño. Las bandejas son graduables en altura. Fácil montaje. Todas las mesas de ordenador incorporan teclado extraíble.

**[ENG]** Mobile computer table with metallic structure and plastic trims, as well as the specially designed wrist rest. Height adjustable trays with optional CPU support. Easy assembly. All of the computer tables have a detachable keyboard.

**[DE]** Mobiler Computertisch für die Unterbringung verschiedener Hardwarekomponenten. Mit Kunststoffapplikationen und Handgelenkstütze. Ablagen und Tastaturlade sind höhenverstellbar und ausziehbar. Leichte Montage.

**[FR]** Poste informatique mobile, structure métal, belles finitions en plastique avec repose poignet intégré. Plateaux réglables en hauteur. Facile à monter. Toutes les tables pour ordinateur intègrent un clavier coulissant.



Todas las bandejas son desplazables.  
All trays are mobile.



Medidas / Sizes (cm)

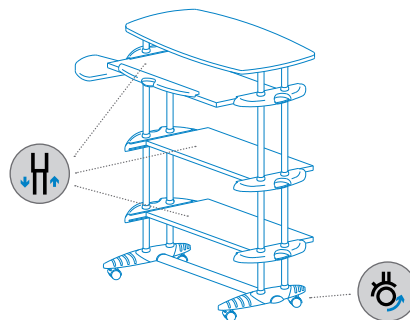
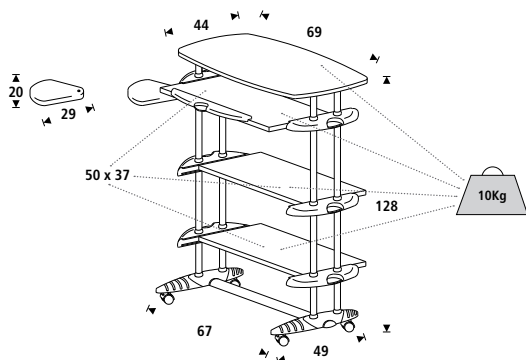

Ref.	cm (embalaje / packaging)	kg / m <sup>3</sup> (embalaje / packaging)
RD-5220	144x53x17	21 kg / 0,120 m <sup>3</sup>

# MESAS ORDENADOR

COMPUTER TABLE • COMPUTER TISCHE • POSTES INFORMATIQUE

**[ESP]** Mesa de ordenador móvil con sistema de bloqueo en las ruedas delanteras, de estructura metálica, con bandeja de teclado extraíble mediante guías y topes metálicos. Fácil montaje.

**[ENG]** Mobile computer table with locking system incorporated in front castors. Metallic structure with metal guided pull-out keyboard tray. Easy assembly.

**[DE]** Mobiler Computertisch ZETA mit ausziehbarer Tastaturlade und feststellbaren Rollen. Aufgrund der Z-Form des Gestells kann der Tastatúrauszug wahlweise nach vorne oder hinten montiert werden.

**[FR]** Table d'ordinateur sur roulettes dont 2 avec système de blocage. Structure métallique avec tablette coulissante pour le clavier. Facile à monter.



Bandeja extraíble  
Pull-out keyboard tray

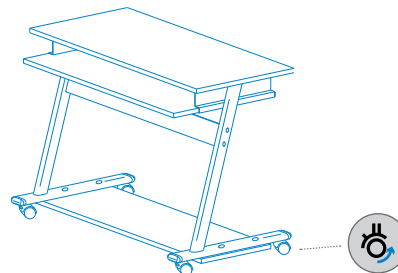
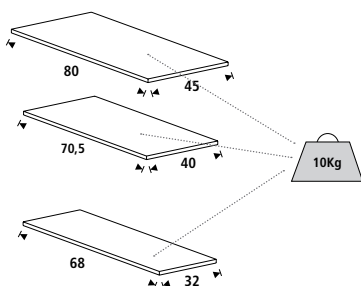
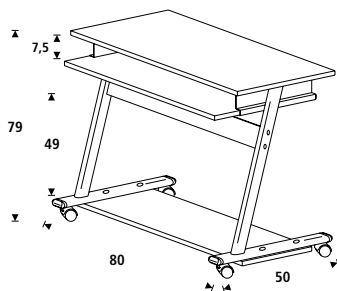

Ref.	cm (embalaje / packaging)	kg / m <sup>3</sup> (embalaje / packaging)
RD-9100	86x55x17	18,35 kg / 0,080 m <sup>3</sup>

# ACCESORIOS

## COMPUTER TABLE • COMPUTER TISCHE • POSTES INFORMATIQUE

### [ESP]

Soportes CPU móvil de estructura metálica y regulables.

[ENG] Adjustable mobile CPU supports with metallic structure.

[DE] Mobiler CPU Trolley aus Metall, in der Breite verstellbar.

[FR] Porte unités centrale en métal, mobiles et réglables. Assemblage facile.

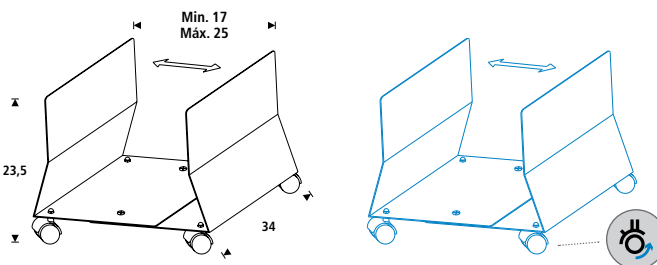

Ref.	cm (embalaje / packaging)	kg / m <sup>3</sup> (embalaje / packaging)
<b>RD-2004</b>	37x22x22	4,5 kg / 0,020 m <sup>3</sup>

[ESP] Soporte para teclado y ratón de estructura metálica y reposamuñecas de diseño. Fácil montaje.

[ENG] Key board and mouse support with metallic structure and specially designed wrist rest. Easy assembled.

[DE] Tastaturlade aus Metall. Mit Mausablage und speziell entworfener Handgelenkstütze.

[FR] Support pour clavier et souris, structure métal, avec repose poignet design.



Medidas / Sizes (cm)

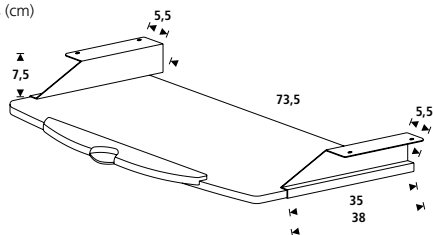

Ref.	cm (embalaje / packaging)	kg / m <sup>3</sup> (embalaje / packaging)
<b>RD-2017</b>	78x46x8	5,6 kg / 0,030 m <sup>3</sup>



Características tejido:  
30% poliéster  
70% PVC  
Reacción al fuego según UNE-EN 13773 (Clase 1)

Fabric features:  
30% Polyestyrene  
70% PVC  
Flame retardant UNE-EN 13773 (Class 1)

Para más información, consultar catálogo SET  
For further information, consult SET catalogue

# CORTINAS ENROLLABLES

ROLLING CURTAINS • ROLLVORHÄNGE • STORES ENROULEURS

**[ESP]** Gama de cortinas enrollables que permiten personalizar los distintos ambientes de una oficina según las necesidades de trabajo. Cortinas enrollables translúcidas de gran calidad, con núcleo de 43mm de aluminio, mecanismo reversible y cadena con opción de instalación a derecha o izquierda. Tejido realizado en poliéster 30% y PVC 70%. Su amplia gama de medidas, acabados de tejidos y de mecanismos permiten una adaptación total a cualquier espacio.







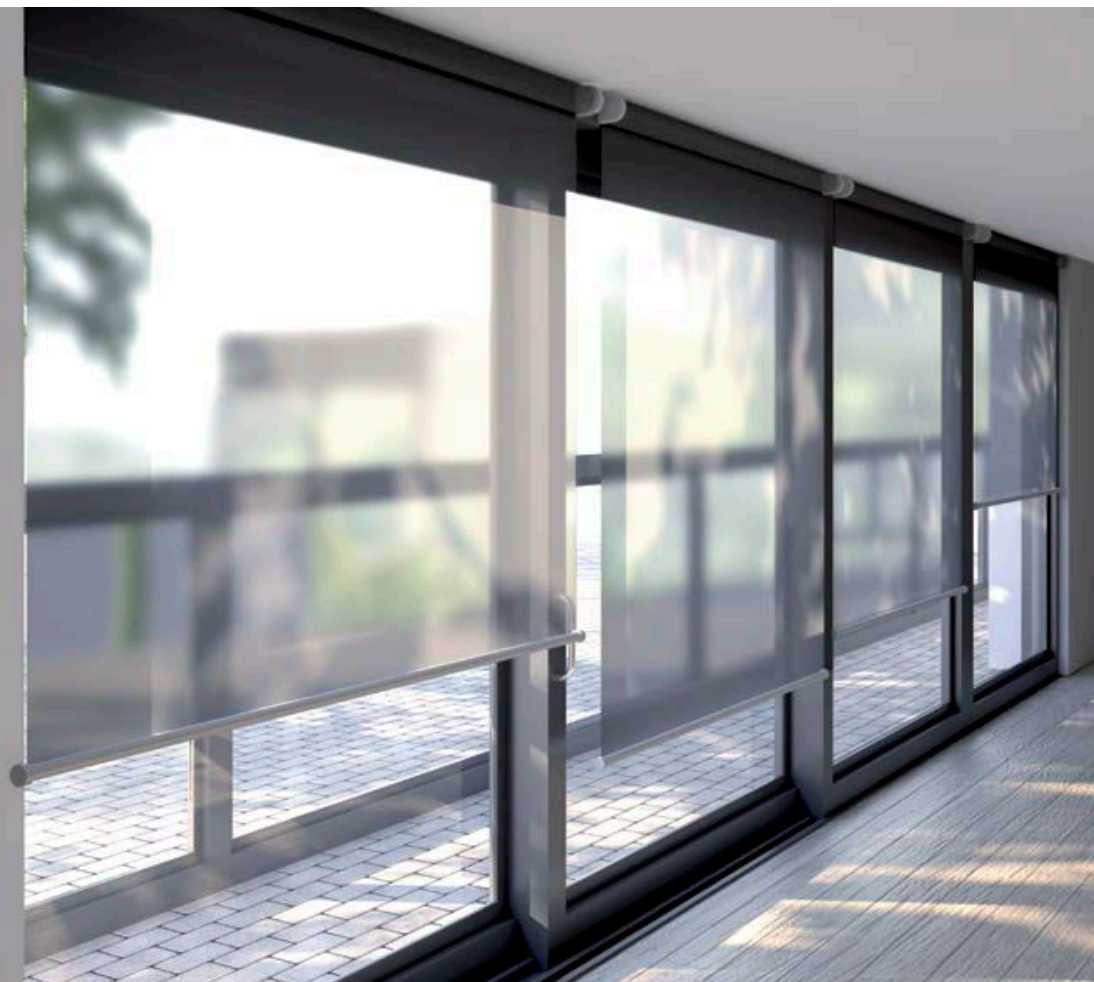

**[ENG]** Range of roller blinds that allow to customize the different environments of an office according to the office needs. High quality translucent roller blinds, with 43mm aluminium core with reversible mechanisms, the option to install the chain to the right or left. Fabric made of 30% polyester and 70% PVC. Its wide range of measures, fabrics and finishes of the mechanism allow a total adaptation to any space.

**[DE]** Produktreihe mit Rollos, die je nach Arbeitsanforderung eine individuelle Gestaltung der verschiedenen Umgebungen eines Büros ermöglichen. Lichtdurchlässige Rollos von hoher Qualität, mit einem 43 mm großen Aluminiumkern mit umkehrbarem Mechanismus sowie Zugkette mit rechts- oder linksseitiger Einbauoption. Gewebe aus 30 % Polyester und 70 % PVC. Das umfangreiche Angebot an verschiedenen Größen, Gewebearten und Ausführungen des Mechanismus ermöglichen die vollständige Anpassung an jeden Raum.

**[FR]** Gamme de stores enrouleurs permettant de personnaliser différents environnements d'un bureau en fonction des besoins de travail. Store enrouleur tamisant de grande qualité, avec un axe de 43 mm en aluminium équipé de mécanismes réversibles et d'une chaîne en option pouvant être installée à droite ou à gauche. Tissu en polyester 30% et PVC 70%. Vaste gamme de dimensions, tissus et finitions du mécanismes pour une adaptation parfaite à tout type d'espace.





			
<p>Sistema de pernos móviles y colocación rápida del bloc de papel. Permite trabajar con cualquier bloc del mercado.</p>	<p>Pizarras metálicas. Permiten la colocación de imanes y de cualquier tipo de complementos magnéticos.</p>	<p>Superficie apta para la escritura directa con rotuladores de borrado en seco. Fácil y limpio borrado con un simple paño o borrador.</p>	<p>Bandeja porta-útiles de serie, como soporte para rotuladores, borrador, etc.</p>
<p>Includes a system of movable bolts which permit easy and rapid fixing of the paper block Suitable.</p>	<p>Metallic surface. It permits the placement of magnets and any other type of magnetic complements.</p>	<p>White surface suitable for any type of whiteboard marker. Dry wipe cleaning is both easy and clean by using a board rubber or cloth.</p>	<p>Storage tray for marker pens, board rubber, etc.</p>
<p>System mit verstellbaren Aufnahmehalterungen. Ermöglicht das Arbeiten mit allen handelsüblichen Blöcken.</p>	<p>Metalltafel. Ermöglicht das Anbringen von Magneten und magnetischen Accessoires.</p>	<p>Weißer Oberfläche, für die Beschriften mit Whiteboard-Markern geeignet. Einfach und sauber mit einem Tuch oder Wischer sowie gelegentlichen Reinigungsspray zu reinigen.</p>	<p>Ablageschiene für Board- und Flipchartmarker.</p>
<p>Système de boulons mobiles et placement rapide du bloc de papier. Permet de travailler avec n'importe quel bloc du marché.</p>	<p>Tableaux métalliques Permettent de placer des aimants et tout autre objet magnétique.</p>	<p>Surface blanche, sur laquelle on peut écrire avec un feutre effaçable à sec. Nettoyage facile et propre avec un simple chiffon ou un effaceur.</p>	<p>Auget porte-matériel placé en série, sert de support pour feutre, effaceur, etc.</p>
			
<p>Brazos extensibles laterales. Permiten ampliar la superficie de la exposición colgando con imanes hojas adicionales.</p>	<p>Pizarras regulables en altura.</p>	<p>Pizarras con ruedas para poder desplazarlas con total comodidad, fijándolas en el lugar de trabajo gracias a su sistema de bloqueo de las ruedas.</p>	<p>Rueda a presión</p>
<p>Lateral extendable arms which permit the exposition surface to be widened, thus allowing the suspension of adjacent papers with magnets.</p>	<p>Flipchart adjustable in height.</p>	<p>Flipchart with castors which permits easy movement and thanks to its braking system it can be fixed in a working position.</p>	<p>Click system castor</p>
<p>Seitlich einsteckbare Bildhalter ermöglichen die Erweiterung der Präsentationsfläche durch das Anbringen zusätzlicher Blätter mit Magneten.</p>	<p>Höhenverstellbare Tafeln.</p>	<p>Tafeln mit Rollen zum einfachen Standortwechsel, feststellbar durch Rollenblockiersystem.</p>	<p>Rolle mit Klicksystem</p>
<p>Potences laterals, extensibles Permettent d'agrandir la surface d'exposition fixation de feuilles par aimants.</p>	<p>Tableaux réglables en hauteur.</p>	<p>Tableaux à roulettes pour pouvoir être déplacés très facilement et être fixés à l'endroit où on en a besoin grâce au système de blocage des roues.</p>	<p>Cliquez sur système castor</p>



Resistente a exteriores



Velcro



Chinchetas



Corcho auto-reparable



Superficie para rotuladores de borrado en seco.

Waterproof

Velcro friendly

Pinnable

Self healing cork

surface for writing with dry-wipe markers

Wasserfest

Klett-tauglich

Pinnbar

Selbstheilender kork

Beschreiben mit trocken abwischbaren Markern.

Étanche

Velcro respectueux de l'environnement

Punaisable

Liège autorégénérant

surface pour écriture au marqueur effaçable à sec

# ÍNDICE • INDEX



**SkinCERAMIC**  
pag 10 · RD-6620CER / RD-6621CER



**SkinPRO**  
pag 12 · RD-6520PRO / RD-6521PRO



**SkinCOLOUR**  
pag 14 · RD-6419R / RD-6420R / RD-6421R



**SkinSHAPE**  
pag 16 · RD-6460 RD-6450 / RD-6440



**SkinAGILE**  
pag 18 · RD-6421AG



**SkinCUBE**  
pag 20 · RD-687654



**SkinMATT**  
pag 22 · RD-6420MATT



**SkinMUSIC**  
pag 24 · RD-6420RM



**SkinLIQUID**  
pag 26 · RD-6820V19



**SkinPINBOARD**  
pag 28 · RD-6248



**SkinPLANNER**  
pag 30 · RD-6420UP



**SkinCLOCK**  
pag 32 · RD-6419CL



**SkinSUPPORT**  
pag 34 · RD-6875



**SkinPROTECT**  
pag 36 · RD-6419PRT



**SkinBLOCK**  
pag 38 · RD-6430R



**SkinnyNOTES**  
pag 40 · RD-4323MX

# ÍNDICE • INDEX



**SkinMAP**  
pag 42 · RD-6421MAPWD

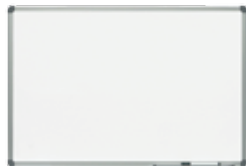

pag 45 · RD-6500  
RD-6400 / RD-6300

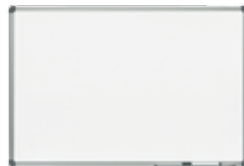

pag 46 · RD-6505MAT

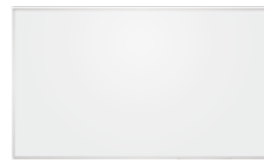

pag 47 · RD-6950  
Doble cara / Double side



pag 48 · RD-6701  
Cristal / Glass



pag 49 · RD-6500GRCH  
Tiza / Chalk



pag 50 · RD-6200  
Corcho / Cork



pag 51 · RD-6600  
Tapizada / Felt

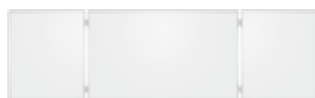

pag 52 · RD-6728



pag 54 · RD-6870 PLUS



pag 56 · RD-6870



pag 58 · RD-8090



pag 59 · RD-6877



pag 60 · RD-6106V19



pag 61 · RD-6120V19



pag 62 · RD-6100V19

# ÍNDICE • INDEX



NEW

pag 63 · RD-S4319



NEW

pag 63 · RD-S4300V19



NEW

pag 64 · RD-S4320



NEW

pag 64 · RD-S4321



pag 64 · RD-530WH / RD-530GR



NEW

pag 65 · I4319



NEW

pag 65 · Smiley15



NEW

pag 65 · RD-S4040MX\*12



NEW

pag 66 · RD-S5050MX

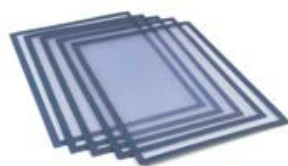

pag 66 · RD-S0301A4



pag 67 · RD-S4200



pag 67 · RD-630



pag 67 · 2981CY



pag 68 · RD-618V15 TRANSFORMER



pag 70 · RD-660



pag 72 · RD-617V15 TOUCH

# ÍNDICE • INDEX



pag 74 · RD-616 ECONOMY



pag 76 · RD-610V19 CLASSIC



pag 78 · RD-600 BASIC



pag 80 · RD-3641V17  
INTERIOR / INDOOR



pag 81 · RD-3651V19  
INTERIOR / INDOOR



pag 82 · RD-3661V19  
INTERIOR / INDOOR



pag 83 · RD-3676V17  
INTERIOR / INDOOR



pag 84 · RD-3686V17  
INTERIOR / INDOOR



pag 85 · RD-3696V17  
INTERIOR / INDOOR



pag 86 · RD-3671V17EX  
INDOOR / OUTDOOR



pag 87 · RD-3681V17EX  
INDOOR / OUTDOOR



pag 88 · RD-3691V17EX  
INDOOR / OUTDOOR



pag 89 · 3630-LC4



pag 90 · RD-3045



pag 91 · RD-3046



pag 91 · RD-3047

# ÍNDICE • INDEX



pag 92 · RD-8304



pag 93 · RD-2980



pag 94 · RD-8100



pag 96 · RD-8210



pag 97 · BS0705S



pag 98 · BSA2CH



pag 99 · BS0720



pag 100 · BS0701



pag 101 · BS0770S



pag 102 · RD-3800



pag 103 · RD-3806



pag 104 · RD-2025



pag 105 · RD-2026



pag 106 · RD-4036  
HOT DESK



pag 108 · RD-4035



pag 109 · RD-300

# ÍNDICE • INDEX



pag 110 · RD-310



pag 111 · RD-3070  
LECTERN LUXE



pag 112 · RD-3080  
LECTERN ECO



pag 113 · RD-4030



pag 114 · RD-3055  
MILAGRO ADJUST



pag 116 · RD-3050  
MILAGRO



pag 117 · RD-5220



pag 118 · RD-9100



pag 119 · RD-2004



pag 119 · RD-2017



## PEDIDOS

**NOVEDAD WEB!**

Los pedidos cursados vía web tendrán un 2% de descuento hasta fin de promoción.  
Si los pedidos no se tramitan a través de la web deben de efectuarse siempre por escrito.

## LISTA DE PRECIOS

Precios sin IVA.  
Válidos a partir del 1 de febrero de 2019.

## PAGOS

El incumplimiento del vencimiento del pago puede provocar la retención de nuevos pedidos hasta la cancelación del impago y la tramitación legal automática a través de nuestras empresas de cobro.  
Anticipado 2%

## GARANTÍA

2-5 años para todos los productos Rocada en condiciones de uso normales.  
Rocada se compromete a entregar un producto de calidad conforme con las especificaciones requeridas.

## PLAZOS DE ENTREGA

Máximo 7 días laborables para pedidos diarios.

## TRANSPORTE

Portes para Península:  
Pedido neto hasta 50 €: cargo de 10 € en concepto de portes.  
A partir de 50 € hasta 150 €: 5 € en concepto de portes.  
A partir de 150 €: portes pagados.  
Portes para Canarias, Ceuta y Melilla: 800 €. El servicio de entrega de la mercancía solo se realizará hasta la puerta de la calle. Si es necesario entregar el material dentro de su destinación, la entrega tendrá un coste extra de +8% sobre PVP.

## INCIDENCIAS Y DEVOLUCIONES

Avisar dentro de las 24 horas de la recepción de la mercancía para incidencias con el transporte. No se aceptarán incidencias pasadas las 24h desde la recepción. Y nunca se aceptaran devoluciones, sin previa confirmación desde Rocada.

## JURISDICCIÓN

Para cuestión que pueda derivarse de la interpretación o aplicación de estas normas el cliente y Rocada se someten expresamente a la jurisdicción y fuero de los Juzgados y Tribunales de la ciudad de Barcelona, con renuncia a cualquier otro si lo hubiere.

## ORDERS

All orders shall be received in writing.

## PAYMENTS

All payments should be received on or before the due date indicated on the invoice. All customers shall be covered by CESCE insurance company. Rocada is forced to communicate any delay or nonpayment. Rocada is keen to offer an extra discount of -2% for in advance payments (before loading).

## GUARANTEE

All Rocada products have between 2 and 5 years guarantee.

## DELIVERY LEADTIME

Between 10-15 working days for stock orders. We shall inform the approximate delivery time once the order has been placed. Each delivery shall be deemed a separate transaction and the failure of any one delivery shall not affect the due performance of the order. Any request to vary the quantity or delivery date of an order must be notified in writing. Ex-works prices.

## CLAIMS - RETURN

All claims for damage to goods or partial loss of goods in transit must be submitted to, and received by us within 2 days of delivery. No goods can be returned without prior notification and an official pick up note produced by us.

## JURISDICTION

Spanish law only shall apply to this contract and all disputes shall be dealt with by the Spanish courts alone.

## MODIFICACIONES / MODIFICATIONS

**[ESP]** Esta tarifa anula las anteriores. Nos reservamos el derecho de modificar sin previo aviso características, formas y medidas de nuestros productos. Tarifa válida excepto error tipográfico.

**[ENG]** This pricelist annuls all the previous ones. We reserve the right to change product specifications, sizes or colors without prior notice. Errors, omissions excluded.







Rocada Spain  
rocada@rocada.com  
**www.rocada.com**

Rocada Deutschland GmbH  
info@rocada.de  
**www.rocada.de**

Distribuido por / Distributed by: