



Ergoline

Ergonomic & comfort

Calidad, confianza, responsabilidad
Quality, trust, responsibility
Qualität, Vertrauen, Verantwortung
Qualité, confiance, responsabilité



Todo el equipo de **Rocada** le da las gracias por su confianza en nuestros productos.
All **Rocada** Team would like to thank you for your confidence in our products.
Das gesamte **Rocada**-Team möchte sich bei Ihnen für Ihr Vertrauen in unsere Produkte bedanken.
Toute l'équipe **Rocada** vous remercie pour votre confiance en ses produits

Marc Roca
CEO

[ESP] Los productos presentados en este catálogo son reproducciones fotográficas impresas, por lo cual pueden ocasionarse leves variaciones de color en el resultado final. Así pues, este catálogo, aún asemejándose mucho a la realidad, sirve sólo a título orientativo.

Rocada se reserva el derecho de modificar sin previo aviso características, medidas y colores de nuestros productos.

[ENG] The products presented in this catalogue are printed photographic reproductions, so there can be colour variations in the end result. Although its contents bear a close resemblance to the actual products, the catalogue is therefore for guidance purposes only.

Rocada reserves the right to change product specifications, sizes or colors without prior notice.

[DE] Bei den in diesem Katalog abgebildeten Produkten handelt es sich um fotografische Wiedergaben, weshalb es hinsichtlich der Farben zu leichten Abweichungen vom Original kommen kann. Trotz weitestgehender Übereinstimmung mit dem Endprodukt ist dieser Katalog also rein informativ zu verstehen.

Rocada behält sich das Recht vor, Merkmale, Abmessungen und Farben der vorgestellten Produkte ohne Vorankündigung zu verändern.

[FR] Les produits présentés dans ce catalogue sont des reproductions photographiques imprimées ; de ce fait, il peut y avoir de légères variations de couleur dans le produit final. Ce catalogue, bien que très proche de la réalité, ne peut donc servir qu'à titre de référence.

Rocada se réserve le droit de modifier sans avis préalable les caractéristiques, les mesures et les couleurs de ses produits.

Stock permanente • Permanent stock Permanente Lagerhaltung • Stock permanent

[ESP] Rapidez • Eficacia • Stock permanente • Entrega inmediata

En un nuevo mundo globalizado, no puedes permitirte el lujo de malgastar espacio y tiempo, Rocada lo sabe. Una estructura de 20.000m² y un almacén de 5.000m² nos permiten disponer de un stock permanente de productos que asegura una entrega inmediata de 7 días.

[ENG] Speed • Efficiency • Permanent stock • Immediate delivery

In a new globalized world, one cannot permit himself the luxury of wasting space and time. Rocada knows this. A structure of 20,000 m² and a warehouse of 5,000 m² allows us to have the product available for immediate 7-day delivery.

[DE] Schnelligkeit • Wirksamkeit • Permanente Lagerung • Sofortige Lieferung

In einer neuen globalisierten Welt kann man sich den Luxus einer Platz- und Zeitverschwendung nicht erlauben. Rocada ist sich dessen bewusst. Ein Betriebsfläche mit 20.000m² und ein Warenlager von 5.000m² erlaubt es uns, über die Produkte zu verfügen und eine sofortige, 7-tägige Lieferung zu garantieren.

[FR] Rapidité • Efficacité • Stock permanent • Livraison immédiate

À l'heure de la mondialisation, vous ne pouvez plus vous permettre le luxe de mal gérer votre espace et votre temps. Rocada en est conscient. Une structure de 20000 m² et un entrepôt de 5000 m² nous permettent de disposer d'un stock permanent de produits afin de garantir une livraison rapide départ usine dans les 7 jours.



Servicio de montaje Montageservice

[ESP] Ofrecemos la posibilidad de montar cualquier material en cualquier punto del territorio español por un módico precio sin pedido mínimo.

[DE] Wir bieten Ihnen die Möglichkeit, unseren Montageservice in jedem Ort in Deutschland zu einem kleinen Aufpreis in Anspruch zu nehmen, unabhängig von der Höhe des Bestellwerts. Bitte erfragen Sie bei uns vorab die Höhe des Aufpreises.

Proyectos a medida Custom projects Benutzerdefinierte Projekte Projets personnalisés

[ESP] Ofrecemos la posibilidad de realizar proyectos a medida con material estándares de nuestro catálogo o con maderas y acabados especiales. Para más información consultar a Rocada.





[ESP] La certificación alemana GS reconocida a nivel mundial como una de las mejores a nivel europeo, garantiza la seguridad, calidad y continuidad de la fabricación del producto, dando al usuario una máxima seguridad y tranquilidad en su compra.

[ENG] GS German certification is world recognised as one of the best in Europe, a guarantee of safety, quality and product production continuity giving the user maximum security and peace of mind when purchasing.

[DE] Die deutsche GS-Zertifizierung ist weltweit als eine der besten europäischen Zertifizierungen anerkannt. Das GS-Zeichen steht für geprüfte Sicherheit, Qualität und Kontinuität der Warenproduktion und signalisiert dem Endverbraucher ein hohes Maß an Sicherheit.

[FR] La certification allemande GS est reconnue au niveau mondial comme une des meilleures en Europe. Elle garantit la sécurité, la qualité et le suivi de production du produit, elle assure au consommateur une sécurité maximale et la tranquillité par rapport à son achat.



ISO 9001:2015

[ESP] La calidad y fiabilidad de nuestros procesos de producción están avalados por la certificación ISO 9001:2015

[ENG] The quality and reliability of our production processes are guaranteed by ISO 9001:2015 certification.

[DE] Die Qualität und Zuverlässigkeit unserer Produktionsprozesse ist durch ISO 9001:2015

[FR] La qualité et la fiabilité de nos processus de production sont garanties par la certification ISO 9001:2015



ISO 14001:2015

[ESP] Respetar y proteger el medioambiente es prioritario en nuestros procesos productivos. El uso de productos reciclados y la utilización razonable de los recursos son prioridades

[ENG] Respect for and protection of the environment are priorities in our production processes. The use of recycled products and the reasonable use of resources are unbending priorities.

[DE] Der Umweltschutz gehört im Rahmen unserer Produktionsprozesse zu den zentralen Anliegen. Der Einsatz von Recyclingmaterialien und die vernünftige Nutzung von natürlichen Ressourcen steht für uns an erster Stelle.

[FR] Respecter et protéger l'environnement est une priorité pour nos processus de production. L'utilisation de matières recyclées et l'utilisation raisonnable des ressources sont des priorités essentielles.



SOFT SEATING

[ESP] BE SOFT es una colección de 'soft seating' formado por diferentes conceptos de funcionalidad. Individuales, dobles y modulares. Los diferentes módulos permiten satisfacer a las nuevas necesidades de reunión, comunicación y relación entre personas siguiendo las nuevas tendencias de creación de espacios donde la persona pasa a ser el núcleo. El programa ha sido concebido bajo un concepto de configuración total, con una gran capacidad de personalización que proporciona al usuario opciones de uso variadas. Materiales como el acero, espumas, tapizados, maderas, ... se unen para formar módulos de utilización libre dando a cualquier ambiente un aire fresco y diferenciador.

[ENG] BE SOFT. It is a collection of 'soft seating' formed by different concepts of functionality. Individual, double and modular, the different modules enables the new needs of having a meeting, communication and relationship between people following the new trends of creation of spaces where the person becomes the focal point. The program has been conceived under a concept of total configuration, with a great capacity of personalization that provides to the user options of varied use. Materials such as steel, foam, upholstery, wood, ... come together to form modules of free use giving any environment a fresh unique touch

[DE] BE SOFT ist eine Kollektion für „soft seating“, die verschiedene Konzepte in Verbindung mit Funktionalität und Benutzerfreundlichkeit umfasst. Individuell, doppelt und modular. Durch die verschiedenen Module können die zeitgemäßen Anforderungen in Bezug auf Versammlungen, Kommunikation und das zwischenmenschliche Verhältnis erfüllt werden, dies unter Berücksichtigung der neuen Trends zur Schaffung von Räumen, bei denen der Mensch im Mittelpunkt steht. Das Programm ist unter dem Konzept der Komplett-Konfiguration entwickelt worden und umfasst umfangreiche Möglichkeiten der persönlichen Gestaltung, die dem Benutzer vielfältige Anwendungsmöglichkeiten bieten. Werkstoffe wie Stahl, Schaumstoff, Polsterungen, Holz usw. werden kombiniert, um Module zur freien Anwendung zu bilden, die jeder Umgebung einen Hauch von Frische und Originalität verleihen.

[FR] BE SOFT est une collection de « soft seating » composée de différents concepts de fonctionnalité. Individuels, doubles et modulaires. Les différents modules satisfont aux nouveaux besoins de réunion, communication et relation entre les personnes, en surfant sur les nouvelles tendances de création d'espaces qui placent la personne au centre du projet. Le programme a été conçu selon un concept de configuration totale, avec une grande capacité de personnalisation qui offre à l'utilisateur des options d'utilisation diverses. Des matériaux comme l'acier, les mousses, la tapisserie, le bois, etc. entrent en communion pour former des modules d'utilisation libre conférant à tout environnement une touche fraîche et différente.









SOFT SEATING

[ESP] BE SOFT es un programa que dispone de diferentes artículos pensados para dar solución a todo tipo de necesidades. Los módulos de 1 y 2 asientos combinados con la pequeña mesa de trabajo, permiten conseguir espacios de ambientes distendidos y agradables, donde la comunicación fluye sin obstáculos. Es la creación de espacios más adaptados a las nuevas tendencias de relación humana.

[ENG] BE SOFT is a program that has different articles designed to solve all kinds of needs. The idea of 1 and 2 seats combined with the small work table allows to achieve spaces of relaxed, pleasant environments where communication flows. The creation of spaces to adapt to the new trends of human relationship.

[DE] BE SOFT ist ein Programm, das über verschiedene Artikel verfügt, die Lösungen für alle erdenklichen Anforderungen bieten. Die Module mit 1 und 2 Sitzen, kombiniert mit einem kleinen Arbeitstisch, ermöglichen die Erschaffung von Räumen mit einer entspannten und angenehmen Atmosphäre, in denen die Kommunikation ungehindert fließen kann. Es entstehen Räume, die besser an die neuen Trends in Sachen zwischenmenschlicher Beziehung angepasst sind.

[FR] BE SOFT est un programme qui dispose de différents articles pensés pour répondre à tous les besoins. Les modules de 1 et 2 places associés à la petite table de travail donnent naissance à des espaces de détente agréables où la communication circule sans obstacle. C'est la création d'espaces plus adaptés aux nouvelles tendances de relation humaine.



NEW



Montaje bajo pedido
Assembly on request

Acabados panel trasero Back panel finishes						Acabados mesa Table finishes	Acabados módulos Module finishes
1	2*	3*	4*	5*	6*	4	4
Gris / Grey Grau / Gris	Rojo / Red Rot / Rouge	Azul / Blue Blau / Bleu	Negro / Black Schwarz / Noir	Naranja Orange	Verde / Green Grün / Vert	Roble / Oak Eiche / Chêne	Negro / Black Schwarz / Noir
*Bajo pedido / *On request / *Auf Anforderung / *Sur demande							

Medidas / Sizes (cm)

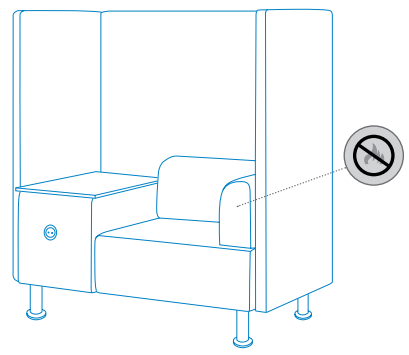
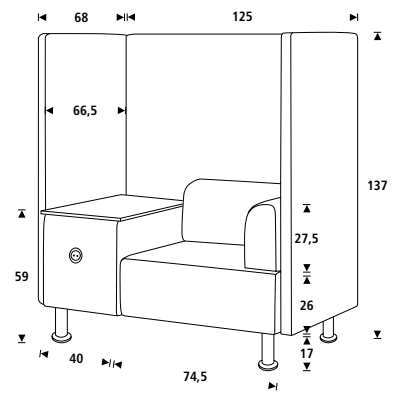

Sistema de enchufe / Plug system included

Ref.	cm (embalaje / packaging)	kg / m ³ (embalaje / packaging)
1806-4-1	139x120x80	100,00 kg / 1,234 m ³

SOFT SEATING

[ESP] BE SOFT es un programa que dispone de diferentes artículos pensados para dar solución a todo tipo de necesidades. Los módulos de 1 y 2 asientos combinados con la pequeña mesa de trabajo, permiten conseguir espacios de ambientes distendidos y agradables, donde la comunicación fluye sin obstáculos. Es la creación de espacios más adaptados a las nuevas tendencias de relación humana.

[ENG] BE SOFT is a program that has different articles designed to solve all kinds of needs. The idea of 1 and 2 seats combined with the small work table allows to achieve spaces of relaxed, pleasant environments where communication flows. The creation of spaces to adapt to the new trends of human relationship.

[DE] BE SOFT ist ein Programm, das über verschiedene Artikel verfügt, die Lösungen für alle erdenklichen Anforderungen bieten. Die Module mit 1 und 2 Sitzen, kombiniert mit einem kleinen Arbeitstisch, ermöglichen die Erschaffung von Räumen mit einer entspannten und angenehmen Atmosphäre, in denen die Kommunikation ungehindert fließen kann. Es entstehen Räume, die besser an die neuen Trends in Sachen zwischenmenschlicher Beziehung angepasst sind.

[FR] BE SOFT est un programme qui dispose de différents articles pensés pour répondre à tous les besoins. Les modules de 1 et 2 places associés à la petite table de travail donnent naissance à des espaces de détente agréables où la communication circule sans obstacle. C'est la création d'espaces plus adaptés aux nouvelles tendances de relation humaine.

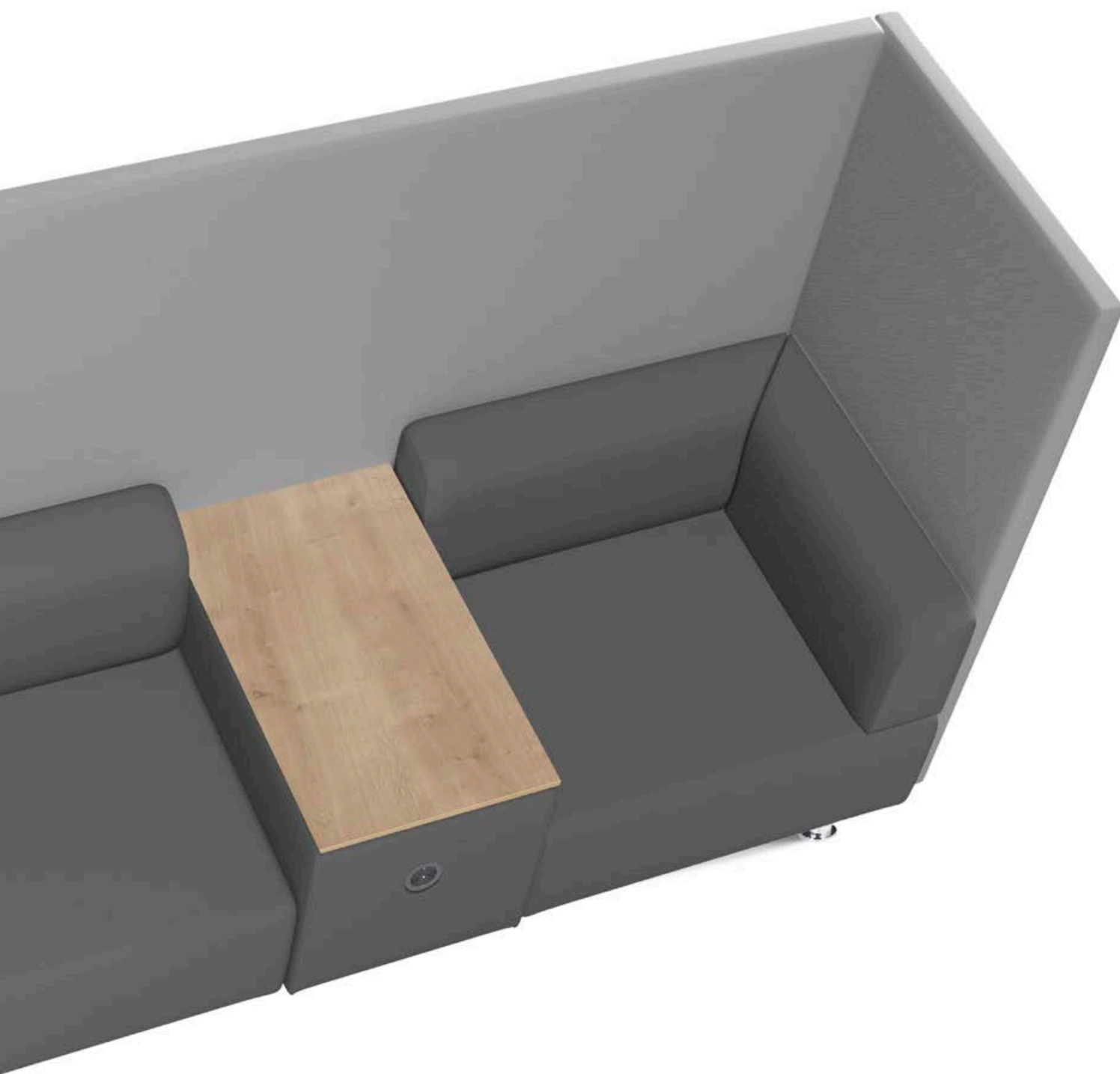







NEW



Montaje bajo pedido
Assembly on request

Acabados panel trasero
Back panel finishes

- 1

Gris / Grey
Grau / Gris
- 2*

Rojo / Red
Rot / Rouge
- 3*

Azul / Blue
Blau / Bleu
- 4*

Negro / Black
Schwarz / Noir
- 5*

Naranja
Orange
- 6*

Verde / Green
Grün / Vert

*Bajo pedido / *On request / *Auf Anforderung / *Sur demande

Acabados mesa
Table finishes

- 4

Roble / Oak
Eiche / Chêne

Acabados módulos
Module finishes

- 4

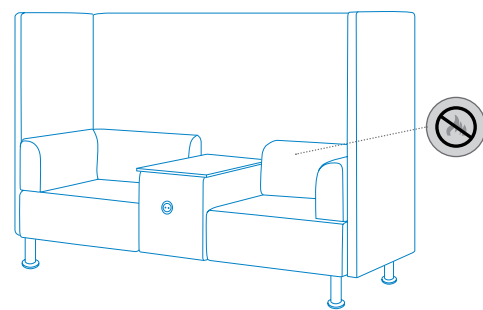
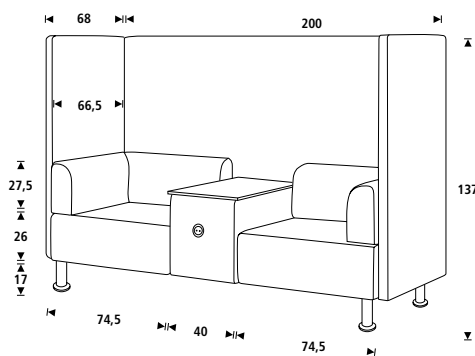
Negro / Black
Schwarz / Noir

Medidas / Sizes (cm)



Sistema de enchufe / Plug system included

Ref.	cm (embalaje / packaging)	kg / m ³ (embalaje / packaging)
1805-4-1	205x140x70	160,00 kg / 2,105 m ³

SOFT SEATING

[ESP] Este módulo individual del programa **BE SOFT** permite combinar el descanso y el trabajo en todos sus estados. El contraste entre su privacidad y su personalidad, permite diseñar espacios polivalentes donde la persona es la protagonista

[ENG] This individual module of the **BE SOFT** program allows you to combine rest and work. The contrast between the privacy and personality allows to design multipurpose spaces where the person is the protagonist.

[DE] Mit diesem Einzelmodul des Programms **BE SOFT** können Erholung und Arbeit in jeglicher Form kombiniert werden. Der Kontrast von Privatsphäre und Persönlichkeit erlaubt den Entwurf von vielseitigen Räumen, bei denen der Mensch im Mittelpunkt steht.

[FR] Ce module individuel du programme **BE SOFT** permet d'associer repos et travail en tout point. Le contraste entre la confidentialité et la personnalité permet de concevoir des espaces polyvalents au cœur desquels se trouve la personne.



NEW



Acabados panel trasero
Back panel finishes

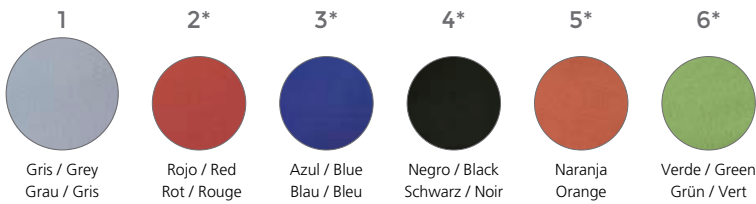

*Bajo pedido / *On request / *Auf Anforterung / *Sur demande

Acabados módulos
Module finishes

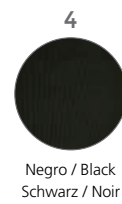

Medidas / Sizes (cm)

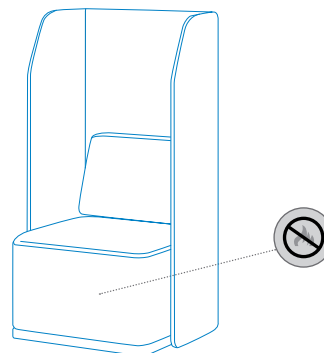
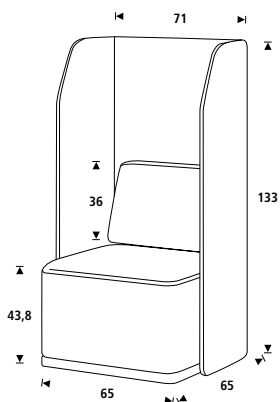

Ref.	cm (embalaje / packaging)	kg / m ³ (embalaje / packaging)
1804-4-1	135x74x69	25,00 kg / 0,689 m ³

TABURETES

STOOLS • HOCKER • TABOURETS

[ESP] Nuevo taburete regulable en altura con diseño innovador acorde con los nuevos momentos del mercado. Complemento perfecto para áreas de descanso, zonas mixtas de trabajo y espacios polivalentes, donde el confort y la estética se dan la mano. Su regulación en altura y su balanceo permiten un uso adecuado para cada momento

[ENG] New height adjustable stool with an innovative design in accordance with the latest market. Perfect complement for rest areas, mixed work areas and multipurpose spaces, where comfort and aesthetics come together. Its regulation in height and its rolling allows an adequate use for each moment.

[DE] Neuer höhenverstellbarer Hocker mit innovativem Design, der den neuen Marktanforderungen gerecht wird. Die ideale Ergänzung für Ruhezonen, gemischte Arbeitsbereiche und Mehrzweckräume, in denen sich Komfort und Ästhetik die Hand reichen. Die Höhenverstellung und die Schwingbewegung ermöglichen einen jederzeit angemessenen Einsatz.

[FR] Nouveau tabouret réglable en hauteur avec un design innovant parfaitement adapté aux nouveaux moments du marché. C'est l'accessoire idéal pour les zones de repos, les zones mixtes de travail et les espaces polyvalents, où le confort et l'esthétique vont main dans la main. Son réglage en hauteur et son balancier lui confèrent une utilisation adaptée à tout moment.





Base basculante
Tilting base

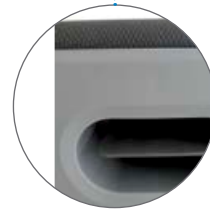

Manecilla / Handle



Acabados estructura
Structure finishes

1

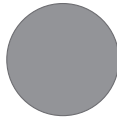

Gris / Grey
Grau / Gris

Acabados asiento
Seat finishes

4



Negro / Black
Schwarz / Noir

Medidas / Sizes (cm)

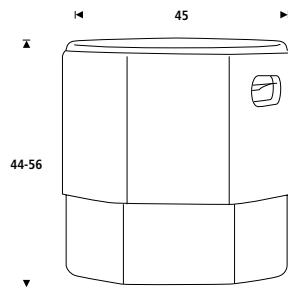

Asiento tapizado en tela ignífuga.
Seat upholstered in fire-resistant fabric.

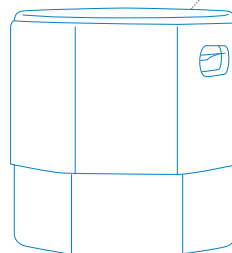

Ref.	cm (embalaje / packaging)	kg / m ³ (embalaje / packaging)
1828-4-1	46x46x45	11,30 kg / 0,095 m ³

SILLONES RECEPCIÓN

WAITING ROOMS SOFA • WARTEZIMMER SOFA • CANAPÉ POUR SALLES D'ATTENTE

[ESP] Sofá de 1, 2 y 3 plazas tapizado en simil piel sobre una estructura robusta. Pies cromados. Ideal para salas de espera, recibidores...

[ENG] 1, 2 and 3 person sofa upholstered in imitation leather over a robust structure. Chromed feet. Ideal for waiting rooms, receptions...

[DE] Sofa (1-, 2- oder 3-Sitzer) mit hochwertigem Bezug aus Lederimitat. Verchromte Fußteile. Ideal für die Einrichtung von Wartezimmern, Empfangs- und Kombizonen. Teilmontiert.

[FR] Canapé 1, 2 et 3 places tapissé en simil cuir sur structure très robuste. Pieds chromés. Idéal pour les salles d'attente, halls d'accueil,...





Medidas / Sizes (cm)

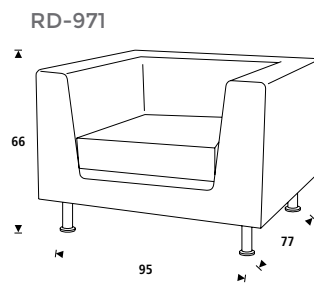
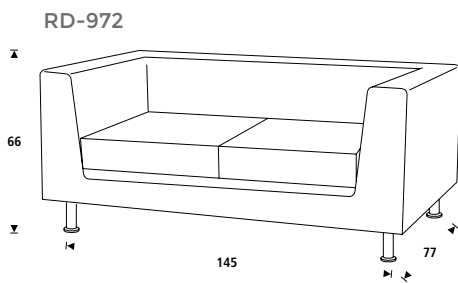
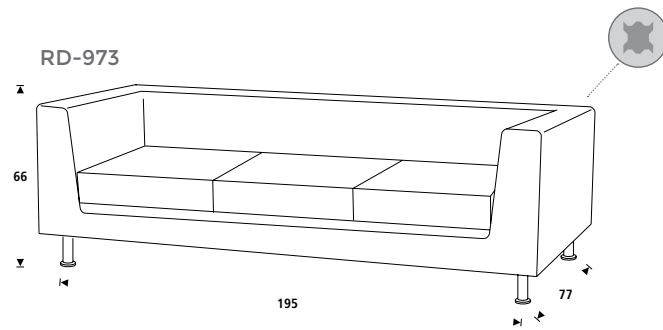

Ref.	cm (embalaje / packaging)	kg / m ³ (embalaje / packaging)
RD-971 (95 cm)	95x91x60	29,60 kg / 0,445 m ³
RD-972 (145 cm)	150x78x60	40 kg / 0,710 m ³
RD-973 (195 cm)	195x78x60	50 kg / 0,940 m ³

SILLAS DIRECCIÓN

DIRECTOR'S CHAIRS • DIREKTIONSSTÜHLE • FAUTEUILS DE DIRECTION

[ESP] Silla de dirección con el asiento y respaldo tapizado en simil piel sobre interior de espuma inyectada. Base de aluminio inyectado y robusto mecanismo sincro profesional. Estructura de unión metálica. Brazos y reposacabezas de serie. Admite ruedas de parquet RD-917. Fácil montaje.

[ENG] Manager chair upholstered in PU leather with deep cushioned seat and back. Aluminium 5 star base and quality castors, asynchro mechanism fully adjustable for comfort. Polished chrome finish and integral cushioned arms. Includes headrest Compatible with RD-917 parquet castors. Easy assembly.

[DE] Ergonomisch geformter Chefsessel. Sitzfläche und Rückenlehne sind mit einem atmungsaktiven Formschaum ausgepolstert. Bezug aus PU - Ledernachbildung. Verchromte Armlehne mit Armauflage. Synchronmechanik mit stufenloser Einstellung des Rückenlehnen-Gegendrucks. Fußgestell aus Aluminium. Kopfstütze und Armlehnen serienmäßig.

[FR] Chaise de direction, siège et dos en simil cuir sur coussins de mousse. Pied en aluminium avec mécanisme de réglage robuste. Accoudoirs et appuie-têtes de série. Possibilité d'installer des roues spéciales pour parquet RD-917. Montage facile.



UNE EN 1335-1 / -2 / -3





Medidas / Sizes (cm)

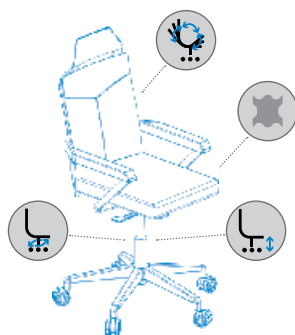
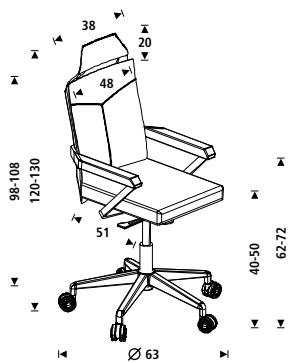

RD-917
Opcional / Optional



Ruedas parquet Ø60mm
Laminated floor castors Ø60mm
Hartbodenrollen Ø60mm
Roulettes parquet Ø60mm

Ref.	cm (embalaje / packaging)	kg / m ³ (embalaje / packaging)
RD-998V15	83x65x60	26,25 Kg / 0,324 m ³
RD-917 (Opcional / Optional)	11x6,3x25	0,5 kg / 0,001 m ³

SILLAS DIRECCIÓN

DIRECTOR'S CHAIRS • DIREKTIONSSTÜHLE • FAUTEUILS DE DIRECTION

[ESP] Silla con ruedas tapizada en simil piel con base metálica cromada y sistema basculante. Incluye brazos metálicos cromados y ruedas de parquet.

[ENG] Wheeled chair upholstered in imitation leather with a chromed metal base and swivelling system mechanism. Includes chromed metal arms and castors.

[DE] Bürostuhl mit einem Bezug aus hochwertigem Lederimitat, Gestell aus verchromtem Metall. Wippmechanik. Hohe Rückenlehne mit Nackenstütze. Armlehnen aus Metall und Hartbodenrollen im Lieferumfang enthalten.

[FR] Chaise à roulettes tapissée en simili cuir sur base métallique chromée et système basculant. Comprend accoudoirs métalliques chromés et roulettes parquet.





Máx
100 kg



Medidas / Sizes (cm)

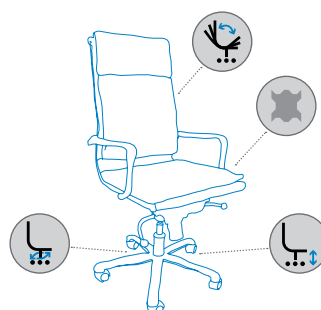
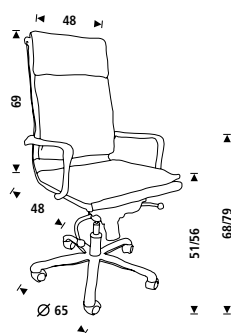

Ref.	cm (embalaje / packaging)	kg / m ³ (embalaje / packaging)
RD-986	92x62x48	17,20 kg / 0,274 m ³

SILLAS DIRECCIÓN

DIRECTOR'S CHAIRS • DIREKTIONSSTÜHLE • FAUTEUILS DE DIRECTION

[ESP] Silla con ruedas tapizada en simil piel con base metálica cromada y sistema fijo y basculante. Incluye brazos metálicos y ruedas de parquet.

[ENG] Wheeled chair upholstered in imitation leather with a chromed metal base and swivelling system mechanism. Includes metal arms and castors.

[DE] Bürodrehstuhl mit einem Bezug aus hochwertigem Lederimitat, Gestell aus verchromtem Metall. Wippmechanik. Metallarmlehnen mit Auflagefläche und Hartbodenrollen im Lieferumfang enthalten.

[FR] Chaise à roulettes tapissée en simili cuir sur base métallique chromée et système basculant. Comprend accoudoirs métalliques et roulettes parquet.





Máx
100 kg



Medidas / Sizes (cm)

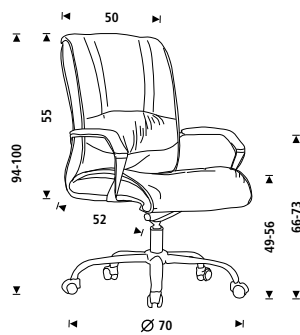

Ref.	cm (embalaje / packaging)	kg / m ³ (embalaje / packaging)
RD-988	78x63x54	19,20 kg / 0,265 m ³

SILLA CONFIDENTE

VISITOR'S CHAIR • BESUCHERSTUHL • CHAISE DE VISITEUR

[ESP] Silla confidente de dirección tapizada en simil piel con base metálica cromada con sistema antivuelco. Brazos metálicos cromados de serie. Viene montada.

[ENG] Visitors or boardroom chair in PU leather with generous size padded seat and back. Cantilever chromed base with anti-topple system. Features padded armrests for superior arm support. Comes assembled.

[DE] Bequemer Besucherstuhl mit einer Polsterung aus atmungsaktivem Formschaum und einem Bezug aus PU - Ledernachbildung Freischwinger - Chromgestell mit integrierter Armauflage.

[FR] Chaise visiteur de direction en simili cuir et base métallique chromée. Bras métalliques chromés de série. Livré monté.



UNE EN 13761
UNE EN 1022



Medidas / Sizes (cm)

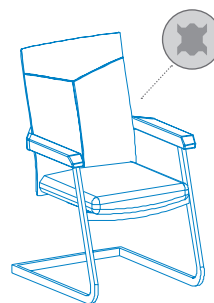
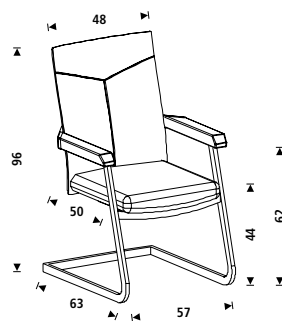

Ref.	cm (embalaje / packaging)	kg / m ³ (embalaje / packaging)
RD-990	70x60x95	20 kg / 0,399 m ³

SILLA CONFIDENTE

VISITOR'S CHAIR • BESUCHERSTUHL • CHAISE DE VISITEUR

[ESP] Silla confidente tapizada en simil piel con estructura metálica cromada. Brazos metálicos cromados de serie.

[ENG] Visitor's chair upholstered in imitation leather with chromed metal base. Chromed metal arms are included.

[DE] Graziler Besucher- und Konferenzstuhl mit Freischwinger-Effekt. Sitzfläche und Rückenlehne mit hochwertiger Ledernachbildung bezogen. Verchromtes Stuhlgestell mit integrierten Armlehnen.

[FR] Chaise visiteur tapissée en simili cuir sur base métallique chromée. Accoudoirs métalliques chromés de série.



UNE EN 13761
UNE EN 1022





Medidas / Sizes (cm)

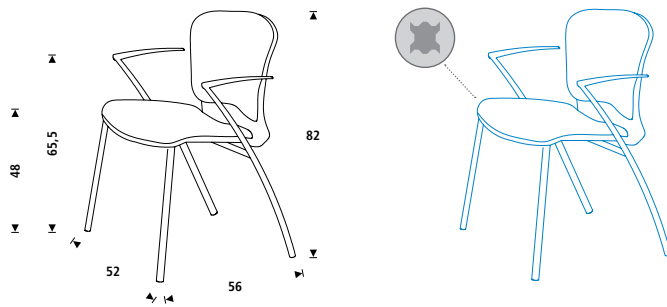

Ref.	cm (embalaje / packaging)	kg / m ³ (embalaje / packaging)
RD-966 (2u.)	59x56x72	18 kg / 0,238 m ³

SILLA CONFIDENTE

VISITOR'S CHAIR • BESUCHERSTUHL • CHAISE DE VISITEUR

[ESP] Silla confidente tapizada en símil piel con base metálica cromada. Brazos metálicos cromados de serie.

[ENG] Visitor's chair upholstered in imitation leather with chromed metal base. Chromed metal arms are included.

[DE] Bequem ausgepolsterter Design-Freischwinger mit Bezug aus hochwertigem Lederimitat. Gestell und Armlehnen verchromt.

[FR] Chaise visiteur tapissée en simili cuir sur base métallique chromée. Accoudoirs métalliques chromés de série.





Medidas / Sizes (cm)

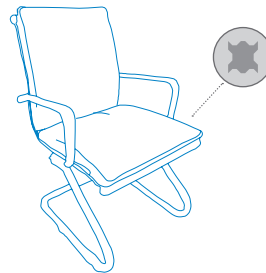
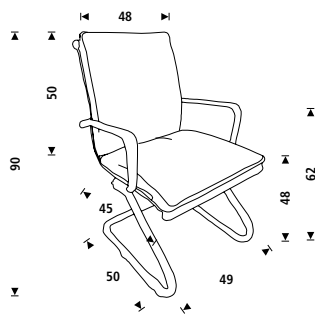

Ref.	cm (embalaje / packaging)	kg / m ³ (embalaje / packaging)
RD-985	79x53x41	11,60 kg / 0,172 m ³

SILLA CONFIDENTE

VISITOR'S CHAIR • BESUCHERSTUHL • CHAISE DE VISITEUR

[ESP] Silla confidente tapizada en simil piel con base tubular metálica y cromada. Brazos incorporados.

[ENG] Visitor's chair upholstered in imitation leather with chromed tubing metal base. Arms incorporated.

[DE] Besucherstuhl, kompakter Freischwinger mit Bezug aus hochwertigem Lederimitat. Verchromtes Stahlrohrgestell mit Armauflagen.

[FR] Chaise visiteur tapissée en simili cuir sur base en tube métallique et chromée. Accoudoirs inclus.





Medidas / Sizes (cm)

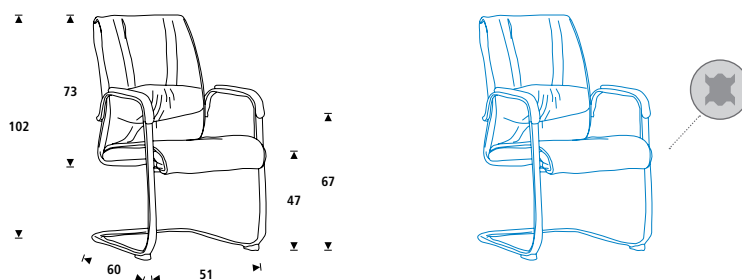

Ref.	cm (embalaje / packaging)	kg / m ³ (embalaje / packaging)
RD-987	80x63x61	16,75 kg / 0,307 m ³

SILLAS OFICINA

OFFICE CHAIRS • BÜROSTÜHLE • SIÈGES DE BUREAU

[ESP] Silla de oficina profesional tapizada en tela ignífuga sobre interior de espuma inyectada, base de aluminio y robusto mecanismo sincro profesional para un uso diario. Brazos regulables de serie. Admite ruedas de parquet RD-917. Fácil montaje.

[ENG] Professional office chair with flame retardant fabric deep cushioned seat and back. Aluminium base and synchro mechanism for daily use. Includes adjustable armrest. Standard adjustable arms. Compatible with RD-917 parquet castors. Easy assembly.

[DE] Ein attraktiver und komfortabler Drehstuhl für den täglichen Büroalltag. Aluminiumgestell mit großen, stabilen Laufrollen. Ergonomisch geformte, hohe Rückenlehne. Feuerhemmender Stoffbezug in 3 Farben. Synchronmechanik. Stufenlose Höhenverstellung mittels bauartgeprüfter Gasdruckfeder. Verstellbare Armlehnen serienmäßig. Leichte Montage

[FR] Chaise de bureau professionnelle tapissée en toile ignifuge, base en aluminium et mécanisme synchro professionnel très robuste pour usage quotidien. Accoudoirs réglables de série. Possibilité d'installer des roues spéciales pour parquet RD-917. Facile à monter.



UNE EN 1335-1 / -2 / -3





Máx
125 kg

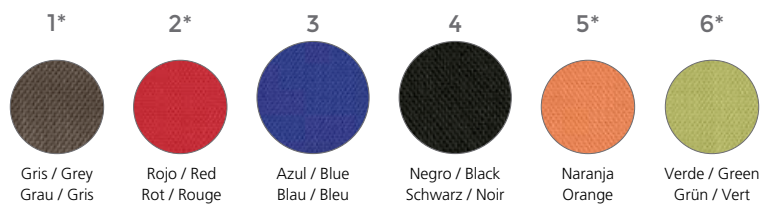

*Bajo pedido / *On request / *Auf Anforderung / *Sur demande

Medidas / Sizes (cm)

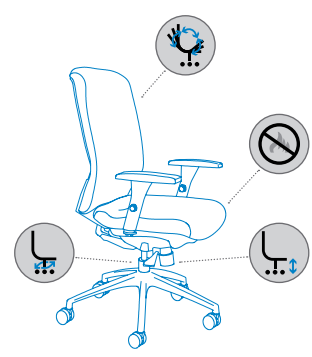
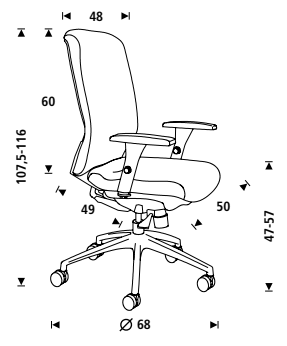

RD-917
Opcional / Optional



Ruedas parquet Ø60mm
Laminated floor castors Ø60mm
Hartbodenrollen Ø60mm
Roulettes parquet Ø60mm



Brazos regulables en altura
Height adjustable armrest

Ref.	cm (embalaje / packaging)	kg / m ³ (embalaje / packaging)
RD-944V15-1*	77x67x42	23,6 kg / 0,217 m ³
RD-944V15-2*	77x67x42	23,6 kg / 0,217 m ³
RD-944V15-3	77x67x42	23,6 kg / 0,217 m ³
RD-944V15-4	77x67x42	23,6 kg / 0,217 m ³
RD-944V15-5*	77x67x42	23,6 kg / 0,217 m ³
RD-944V15-6*	77x67x42	23,6 kg / 0,217 m ³
RD-917 (Opcional / Optional)	11x6,3x25	0,5 kg / 0,001 m ³

SILLAS OFICINA

OFFICE CHAIRS • BÜROSTÜHLE • SIÈGES DE BUREAU

[ESP] Silla de oficina profesional con el asiento tapizado en tela ignífuga sobre interior de espuma inyectada y el respaldo de malla negra regulable en altura tapizado sobre estructura inyectada en polímero técnico, base de polímero inyectado y robusto mecanismo sincro. Regulación lumbar y asiento desplazable. Brazos regulables de serie. Admite ruedas de parquet RD-917. Fácil montaje.

[ENG] Professional office chair with the seat upholstered in fire-resistant fabric over an interior of injected foam and an upholstered adjustable-height backrest on a structure of injected technical polymer, base of injected aluminium with robust synchro mechanism. Sliding seat and lumbar adjustment. Standard adjustable arms. Admits RD-917 parquet wheels. Easy assembly.

[DE] Komfortabler Drehstuhl mit Polsterschaum-Sitz für den Büroalltag. Feuerabweisender Stoffbezug. Höhenverstellbare Rückenlehne aus Kunststoffspritzguss mit Geflechtbezug. Solide Synchronmechanik und Fußgestell aus Aluminiumdruckguss. Sitztiefenverstellung. Verstellbare Armlehnen serienmäßig. Kann mit Hartbodenrollen (RD 917) ausgestattet werden.

[FR] Chaise de bureau professionnelle avec assise tapissée en toile ignifugée sur coussin en mousse injectée et dossier tapissé réglable en hauteur sur structure injectée en polymère technique, base en aluminium injecté et robuste mécanisme synchro. Réglage lombaire. Accoudoirs réglables de série. Possibilité d'installer des roues spéciales pour parquet RD-917. Facile à monter.



NEW

RD-937HR
Reposabrazos (opcional)
Headrest (optional)
30 x 19 cm

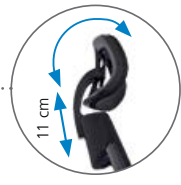

Respaldo regulable
Adjustable backrest



NEW

Asiento desplazable
Sliding seat



**CERTIFICADA
CERTIFIED**

UNE EN 1335-1 / -2 / -3

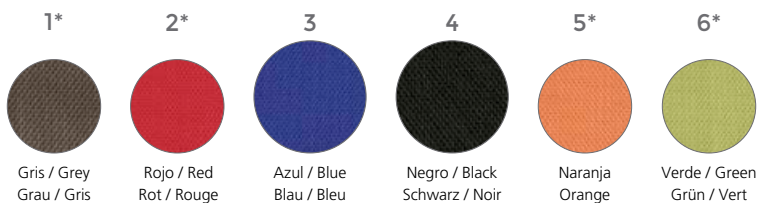

*Bajo pedido / *On request / *Auf Anforderung / *Sur demande

Medidas / Sizes (cm)

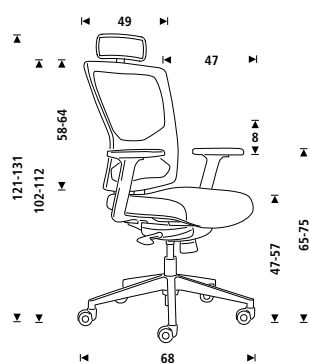

RD-917
Opcional / Optional



Ruedas parquet Ø60mm
Laminated floor castors Ø60mm
Hartbodenrollen Ø60mm
Roulettes parquet Ø60mm



Regulación lumbar
Lumbar height
adjustable system



Brazos regulables en altura
Height adjustable armrest

Ref.	cm (embalaje / packaging)	kg / m ³ (embalaje / packaging)
RD-937V19-1*	67x67x47	21 kg / 0,211 m ³
RD-937V19-2*	67x67x47	21 kg / 0,211 m ³
RD-937V19-3	67x67x47	21 kg / 0,211 m ³
RD-937V19-4	67x67x47	21 kg / 0,211 m ³
RD-937V19-5*	67x67x47	21 kg / 0,211 m ³
RD-937V19-6*	67x67x47	21 kg / 0,211 m ³
RD-937HR reposacabezas - headrest	35x25x12	1,35 kg / 0,010 m ³
RD-917 (Opcional / Optional)	11x6,3x25	0,5 kg / 0,001 m ³

SILLAS OFICINA

OFFICE CHAIRS • BÜROSTÜHLE • SIÈGES DE BUREAU

[ESP] Silla oficina tapizada en tela ignífuga sobre interior de espuma inyectada, base de polímero técnico y robusto mecanismo sincro basculante para un uso diario. Brazos regulables de serie. Admite ruedas de parquet RD-917. Fácil montaje.

[ENG] Office chair with flame retardant fabric deep cushioned seat and back. Polymer base and synchro mechanism for daily use. Standard adjustable arms. Compatible with RD-917 parquet castors. Easy assembly.

[DE] Komfort- Bürostuhl mit Muldensitz und feuerbeständigem Stoffbezug. Synchronmechanik. Kunststofffuß. Stufenlose Höherverstellung mittels bauartgeprüfter Gasdruckfeder. Verstellbare Armlehnen serienmäßig. Leichte Montage.

[FR] Chaise de bureau ergonomique, toile ignifugé et mécanisme synchrone-basculant. Rembourrage mousse et roulettes. Pour usage quotidien. Accoudoirs réglables de série. Facile à monter.



UNE EN 1335-1 / -2 / -3

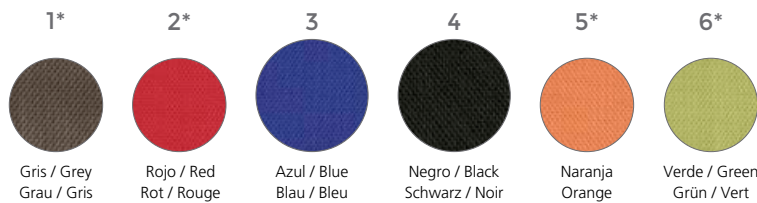

*Bajo pedido / *On request / *Auf Anforderung / *Sur demande

Medidas / Sizes (cm)

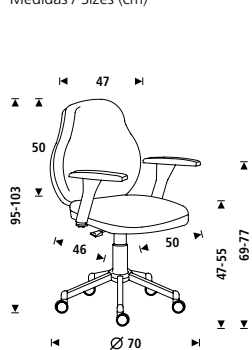

RD-917
Opcional / Optional



Ruedas parquet Ø60mm
Laminated floor castors Ø60mm
Hartbodenrollen Ø60mm
Roulettes parquet Ø60mm



Brazos regulables en altura
Height adjustable armrest

Ref.	cm (embalaje / packaging)	kg / m ³ (embalaje / packaging)
RD-939V19-1*	66x63x33	18,10 kg / 0,137 m ³
RD-939V19-2*	66x63x33	18,10 kg / 0,137 m ³
RD-939V19-3	66x63x33	18,10 kg / 0,137 m ³
RD-939V19-4	66x63x33	18,10 kg / 0,137 m ³
RD-939V19-5*	66x63x33	18,10 kg / 0,137 m ³
RD-939V19-6*	66x63x33	18,10 kg / 0,137 m ³
RD-917 (Opcional / Optional)	11x6,3x25	0,5 kg / 0,001 m ³

SILLAS OFICINA

OFFICE CHAIRS • BÜROSTÜHLE • SIÈGES DE BUREAU

[ESP] Silla de oficina operativa con asiento tapizado con tela ignifuga sobre ignifuga sobre interior de espuma inyectada, respaldo inyectado en polímero técnico tapizado con malla. Base en polímero técnico y robusto mecanismo sincro - basculante para un uso diario. Regulación lumbar. Brazos regulables de serie. Admite ruedas de parquet RD-917. Fácil montaje.

[ENG] Operative office chair of fire-resistant fabric over an interior of injected foam, mesh backrest in injected technical polymer. Technical polymer base and robust swivelling mechanism for daily use. Lumbar adjustment. Standard adjustable arms. Admits RD-917 parquet wheels. Easy assembly.

[DE] Bürostuhl für den täglichen Gebrauch. Polsterschaum-Sitzfläche, mit feuerhemmendem Stoffbezug. Rückenlehne aus Kunststoffspritzguss mit Netzbezug. Mit Wippmechanik und Kunststofffußgestell. Verstellbare Armlehnen serienmäßig. Kann mit Hartbodenrollen (RD-917) ausgestattet werden.

[FR] Chaise de bureau opérationnelle en toile ignifugée sur coussin en mousse injectée, dossier injecté en polymère technique tapissé en maille. Base polymère technique et robuste mécanisme basculant pour utilisation quotidienne. Réglage lombaire. Accoudoirs réglables de série. Possibilité d'installer des roues spéciales pour parquet RD-917. Montage facile.



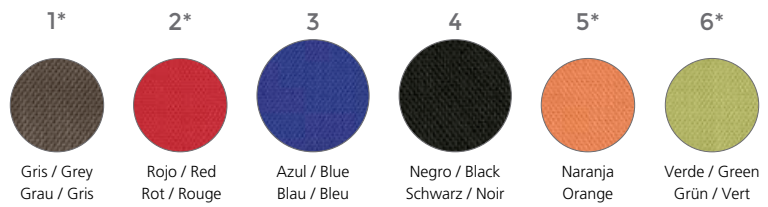

*Bajo pedido / *On request / *Auf Anforderung / *Sur demande

Medidas / Sizes (cm)

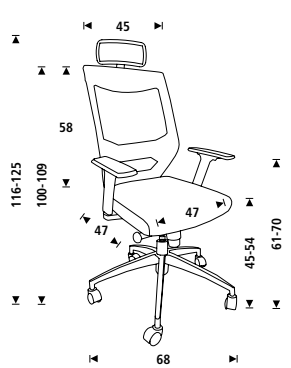

RD-917
Opcional / Optional



Ruedas parquet Ø60mm
Laminated floor castors Ø60mm
Hartbodenrollen Ø60mm
Roulettes parquet Ø60mm



Regulación lumbar
Lumbar height adjustable system



Brazos regulables en altura
Height adjustable armrest

Ref.	cm (embalaje / packaging)	kg / m ³ (embalaje / packaging)
RD-908W-1*	68x63x29	17,50 kg / 0,124 m ³
RD-908W-2*	68x63x29	17,50 kg / 0,124 m ³
RD-908W-3	68x63x29	17,50 kg / 0,124 m ³
RD-908W-4	68x63x29	17,50 kg / 0,124 m ³
RD-908W-5*	68x63x29	17,50 kg / 0,124 m ³
RD-908W-6*	66x63x33	17,50 kg / 0,124 m ³
RD-908WHR reposacabezas opcional / headrest optional	35x25x12	1,35 kg / 0,010 m ³
RD-917 (Opcional / Optional)	11x6,3x25	0,5 kg / 0,001 m ³

SILLAS OFICINA

OFFICE CHAIRS • BÜROSTÜHLE • SIÈGES DE BUREAU

[ESP] Silla de oficina operativa con asiento tapizado con tela ignífuga sobre interior de espuma inyectada, respaldo inyectado en polímero técnico tapizado con malla. Base en polímero técnico y robusto mecanismo sincro - basculante para un uso diario. Regulación lumbar. Brazos regulables de serie. Admite ruedas de parquet RD-917. Fácil montaje.

[ENG] Operative office chair of fire-resistant fabric over an interior of injected foam, mesh backrest in injected technical polymer. Technical polymer base and robust swivelling mechanism for daily use. Lumbar adjustment. Standard adjustable arms. Admits RD-917 parquet wheels. Easy assembly.

[DE] Bürostuhl für den täglichen Gebrauch. Polsterschaum-Sitzfläche, mit feuerhemmendem Stoffbezug. Rückenlehne aus Kunststoffspritzguss mit Netzbezug. Mit Wippmechanik und Kunststofffußgestell. Verstellbare Armlehnen serienmäßig. Kann mit Hartbodenrollen (RD-917) ausgestattet werden.

[FR] Chaise de bureau opérationnelle en toile ignifugée sur coussin en mousse injectée, dossier injecté en polymère technique tapissé en maille. Base polymère technique et robuste mécanisme basculant pour utilisation quotidienne. Réglage lombaire. Accoudoirs réglables de série. Possibilité d'installer des roues spéciales pour parquet RD-917. Montage facile.

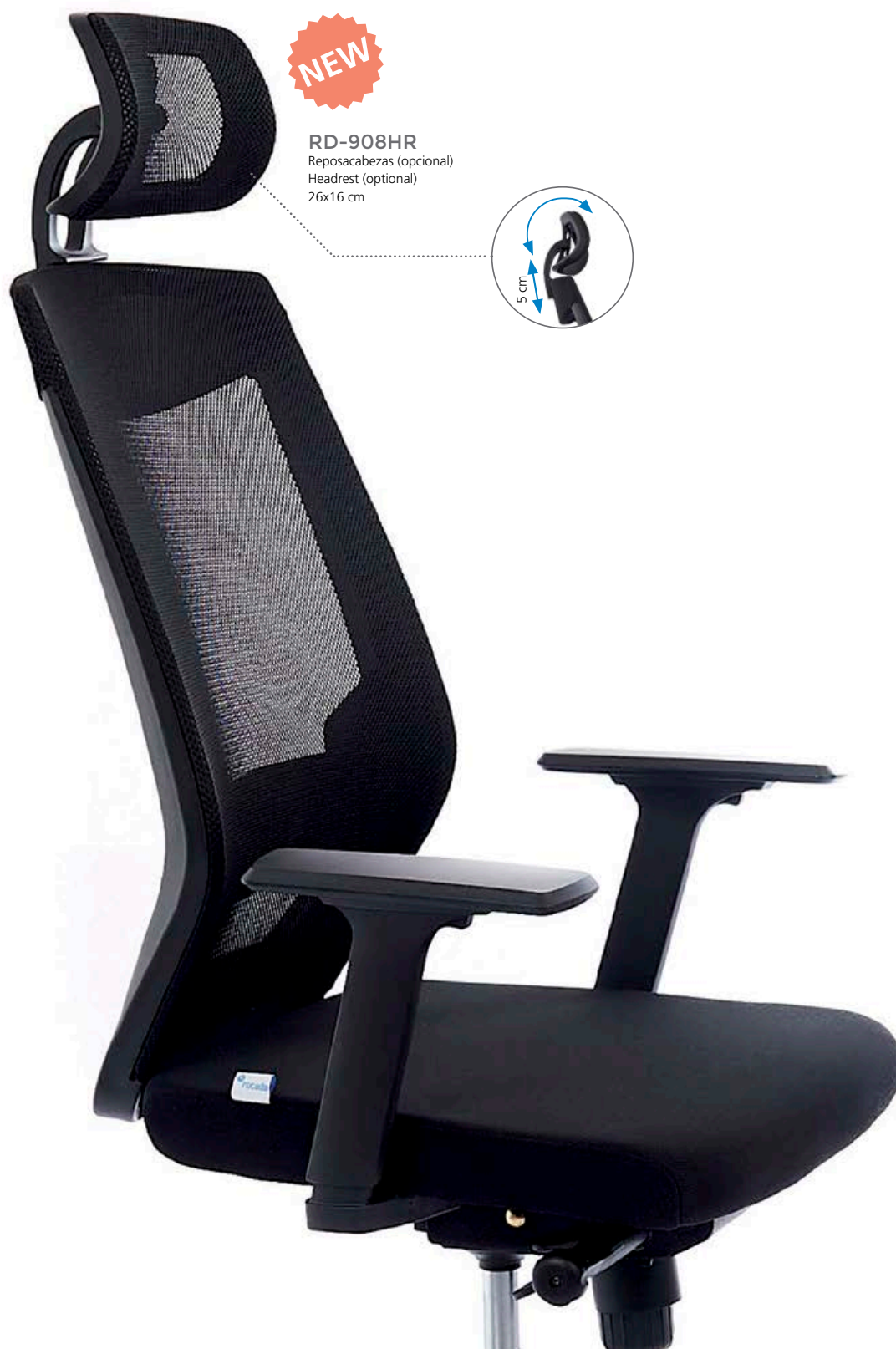



Màx
125 kg

8h

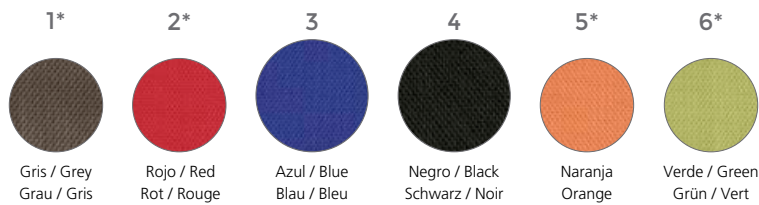

*Bajo pedido / *On request / *Auf Anforderung / *Sur demande

Medidas / Sizes (cm)

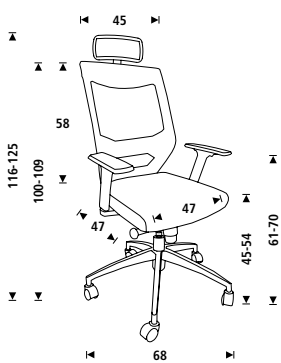

RD-917
Opcional / Optional



Ruedas parquet Ø60mm
Laminated floor castors Ø60mm
Hartbodenrollen Ø60mm
Roulettes parquet Ø60mm

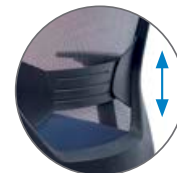

Regulación lumbar
Lumbar height
adjustable system



Brazos regulables en altura
Height adjustable armrest

Ref.	cm (embalaje / packaging)	kg / m ³ (embalaje / packaging)
RD-908-1*	68x63x29	17,50 kg / 0,124 m ³
RD-908-2*	68x63x29	17,50 kg / 0,124 m ³
RD-908-3	68x63x29	17,50 kg / 0,124 m ³
RD-908-4	68x63x29	17,50 kg / 0,124 m ³
RD-908-5*	68x63x29	17,50 kg / 0,124 m ³
RD-908-6*	66x63x33	17,50 kg / 0,124 m ³
RD-908HR reposacabezas opcional / headrest optional	35x25x12	0,5 kg / 0,010 m ³
RD-917 (Opcional / Optional)	11x6,3x25	0,5 kg / 0,001 m ³

SILLAS OFICINA

OFFICE CHAIRS • BÜROSTÜHLE • SIÈGES DE BUREAU

[ESP] Silla de oficina operativa con asiento tapizado con tela ignífuga sobre interior de espuma inyectada, respaldo inyectado en polímero técnico tapizado con malla. Base en polímero técnico y robusto mecanismo basculante para un uso diario. Brazos regulables de serie. Admite ruedas de parquet RD-917. Fácil montaje.

[ENG] Operative office chair of fire-resistant fabric over an interior of injected foam, mesh backrest in injected technical polymer. Technical polymer base and robust swivelling mechanism for daily use. Standard adjustable arms. Admits RD-917 parquet wheels. Easy assembly.

[DE] Bürostuhl für den täglichen Gebrauch. Polsterschaum-Sitzfläche, mit feuerhemmendem Stoffbezug. Rückenlehne aus Kunststoffspritzguss mit Netzbezug. Mit Wippmechanik und Kunststofffußgestell. Verstellbare Armlehnen serienmäßig. Kann mit Hartbodenrollen (RD-917) ausgestattet werden.

[FR] Chaise de bureau opérationnelle en toile ignifugée sur coussin en mousse injectée, dossier injecté en polymère technique tapissé en maille. Base polymère technique et robuste mécanisme basculant pour utilisation quotidienne. Accoudoirs réglables de série. Possibilité d'installer des roues spéciales pour parquet RD-917. Montage facile.



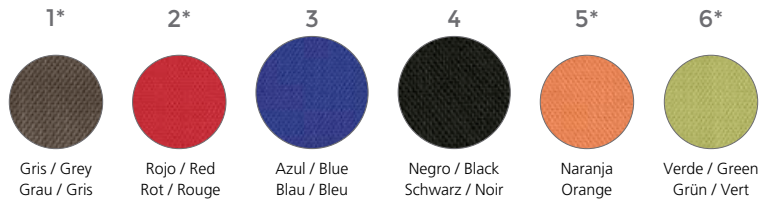
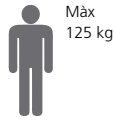

*Bajo pedido / *On request / *Auf Anforderung / *Sur demande

Medidas / Sizes (cm)

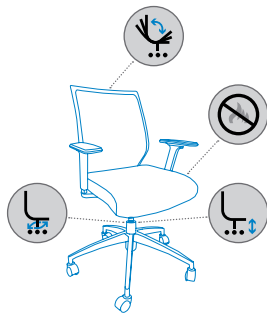
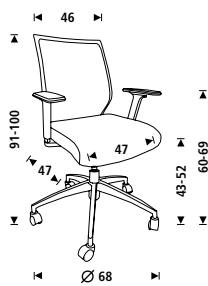

RD-917
Opcional / Optional



Ruedas parquet Ø60mm
Laminated floor castors Ø60mm
Hartbodenrollen Ø60mm
Roulettes parquet Ø60mm



Brazos regulables en altura
Height adjustable armrest

Ref.	cm (embalaje / packaging)	kg / m ³ (embalaje / packaging)
RD-907-1*	64x63x34	14 kg / 0,137 m ³
RD-907-2*	64x63x34	14 kg / 0,137 m ³
RD-907-3	64x63x34	14 kg / 0,137 m ³
RD-907-4	64x63x34	14 kg / 0,137 m ³
RD-907-5*	64x63x34	14 kg / 0,137 m ³
RD-907-6*	64x63x34	14 kg / 0,137 m ³
RD-917 (Opcional / Optional)	11x6,3x25	0,5 kg / 0,001 m ³

SILLAS OFICINA

OFFICE CHAIRS • BÜROSTÜHLE • SIÈGES DE BUREAU

[ESP] Silla oficina operativa con asiento tapizado con tela sobre interior de espuma inyectada, base de polímero técnico y mecanismo de contacto permanente. Respaldo regulable en altura. Brazos de serie regulables en altura. Admite ruedas de parquet RD-917. Fácil montaje.

[ENG] Office chair made of fabric on the inside of injected foam, technical polymer base and permanent contact mechanism. Adjustable backrest in height. Adjustable arms in height included. It admits wheels of RD-917. Easy to assemble.

[DE] Bürostuhl mit Polsterschaum-Sitzfläche und Stoffbezug, Basis aus technischem Kunststoff und Permanentkontaktmechanik. Höhenverstellbare Rückenlehne. Serienmäßig mit höhenverstellbaren Armlehnen. Kann mit Parkettrollen RD-917 ausgestattet werden. Einfache Montage.

[FR] Chaise de bureau opérationnelle en tissu sur intérieur mousse injectée, base en polymère technique et mécanisme de contact permanent. Dossier réglable en hauteur. Accoudoirs de série réglables en hauteur. Possibilité d'installer des roues spéciales pour parquet RD-917. Montage facile.



NEW



Màx
125 kg



1



Gris / Grey
Grau / Gris

2



Burdeos / Burgundy
Burgund / Bordeaux

3



Azul / Blue
Blau / Bleu

4



Negro / Black
Schwarz / Noir

Medidas / Sizes (cm)

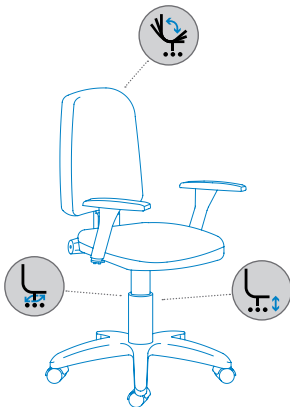
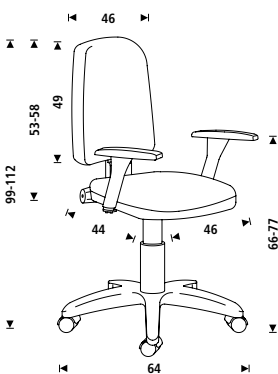

RD-917

Opcional / Optional



Ruedas parquet Ø60mm
Laminated floor castors Ø60mm
Hartbodenrollen Ø60mm
Roulettes parquet Ø60mm

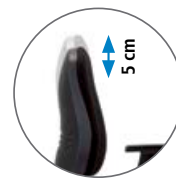

Regulación respaldo
Backrest regulation



Brazos regulables en altura
Height adjustable armrest

Ref.	cm (embalaje / packaging)	kg / m ³ (embalaje / packaging)
RD-911-1+958	64x63x34	14 kg / 0,137 m ³
RD-911-2+958	64x63x34	14 kg / 0,137 m ³
RD-911-3+958	64x63x34	14 kg / 0,137 m ³
RD-911-4+958	64x63x34	14 kg / 0,137 m ³
RD-917 (Opcional / Optional)	11x6,3x25	0,5 kg / 0,001 m ³

SILLAS OFICINA

OFFICE CHAIRS • BÜROSTÜHLE • SIÈGES DE BUREAU

[ESP] Silla oficina operativa con asiento tapizado con tela sobre de espuma inyectada, base de polímero técnico y mecanismo de contacto permanente. Brazos de serie según modelo. Admite ruedas de parquet RD-917. Fácil montaje.

[ENG] Office chair with fabric deep cushioned seat and back. Polymer base and permanent contact mechanism. Includes armrest. Compatible with RD-917 parquet castors. Easy assembly.

[DE] Standard - Bürostuhl mit Kunststoffgestell und feuerfestem Stoffbezug. Permanentkontaktmechanik Leichte Montage.

[FR] Chaise de bureau, toile ignifugé et mécanisme de contact permanent. Accoudoirs de série. Facile à monter.



RD-930/4 + 956

Con brazos
With armrest



Máx
100 kg



8h

RD-930/4
Sin brazos
Without armrest

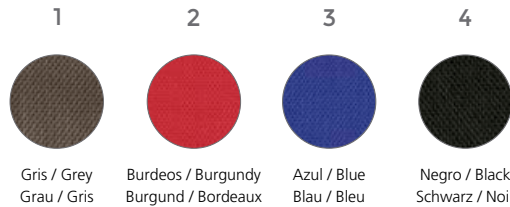

1
Gris / Grey
Grau / Gris

2
Burdeos / Burgundy
Burgund / Bordeaux

3
Azul / Blue
Blau / Bleu

4
Negro / Black
Schwarz / Noir

Medidas / Sizes (cm)

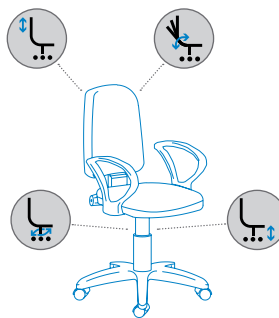
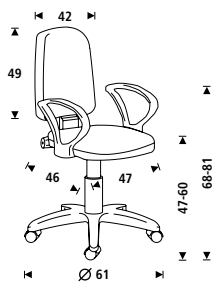
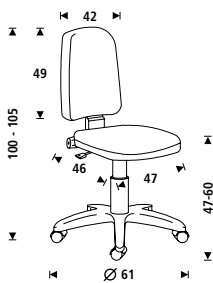

RD-917
Opcional / Optional



Ruedas parquet Ø60mm
Laminated floor castors Ø60mm
Hartbodenrollen Ø60mm
Roulettes parquet Ø60mm



Regulación respaldo
Backrest regulation

	Ref.	cm (embalaje / packaging)	kg / m ³ (embalaje / packaging)
con brazos / with armrest	● RD-930/1 + 956	60x57x27	12,25 kg / 0,092 m ³
	● RD-930/2 + 956	60x57x27	12,25 kg / 0,092 m ³
	● RD-930/3 + 956	60x57x27	12,25 kg / 0,092 m ³
	● RD-930/4 + 956	60x57x27	12,25 kg / 0,092 m ³
sin brazos / without armrest	● RD-930/1	60x57x27	9,75 kg / 0,092 m ³
	● RD-930/2	60x57x27	9,75 kg / 0,092 m ³
	● RD-930/3	60x57x27	9,75 kg / 0,092 m ³
	● RD-930/4	60x57x27	9,75 kg / 0,092 m ³
RD-917 (Opcional / Optional)		11x6,3x25	0,5 kg / 0,001 m ³

SILLA COLABORATIVA

COLLABORATIVE CHAIRS • SEMINARSTÜHLE UND TEAMSTÜHLE
SIÈGE DE TRAVAIL COLLABORATIF

[ESP] Nueva silla colaborativa con base y cuerpo central en polímero técnico flexible con asiento y respaldo tapizado. Pala de trabajo de grandes dimensiones que permite ordenadores portátiles, ajustable a derecha e izquierda sin necesidad de desmontaje gracias a su sistema de rotación 360°. Su diseño permite un acceso fácil y gracias a sus brazos incorporados se consigue una máxima comodidad. La base permite almacenar todo tipo de objetos y sus ruedas facilitan el desplazamiento sin esfuerzo entre diferentes áreas.

[ENG] New collaborative chair with flexible seat, without pneumatic adjustments to worry about keeps users comfortable. Personal work surface is adjustable, non-handed, and large enough to support digital handbook. Open seat design offers easy acces, while arms serve as backpack hooks. Folding clipboard, expands seat space for you at anytime. Swivel seat keeps open sightlines between studen and instructor. Base keeps backpacks and personal belongings out of the aisle. Casters lend mobility for quick, easy transitions between rooms.

[DE] Neuartiger Meeting und Hörsaalstuhl mit integrierter, flexibel einstellbarer Arbeitsplatte 50x30cm. Die Arbeitsplatte kann links-/ rechtsseitig um jeweils 180° gedreht werden Weiße Kunststoff-Sitzschale mit schwarzer Sitzpolsterung. Sitz ist 360° drehbar. Die Gestell-Konstruktion ist aus grauem Kunststoff gefertigt und bietet Ablage-Platz, z.B. für eine Tasche oder Unterlagen. Insgesamt 6 Laufrollen sorgen für einen sicheren Stand, aber ebenso für ein schnelles Verbringen von einem Raum zum anderen.

[FR] Nouveau siège de travail collaboratif avec base et corps central en polymère technique souple, et assise et dossier tapissés. Tablette de grandes dimensions qui permet de poser un ordinateur portable, réglable sur la droite et la gauche sans besoin de la démonter, grâce à son système de rotation à 360°. Son design permet de s'asseoir facilement et ses accoudoirs incorporés offrent un confort maximum. La base peut accueillir tous types d'objets et les roulettes permettent de déplacer le fauteuil sans effort d'une pièce à l'autre





Ver vídeo
See video



Carcasa monobloc en blanco y tapizado según referencia
White monoblock body and upholstered according each ref.

Para medidas y aplicaciones especiales, consultar a Rocada.
For special sizes and uses contact Rocada.
Sonderabmessungen und Sonderanfertigungen auf Anfrage.
Veuillez contacter Rocada pour des dimensions et applications spécifiques.

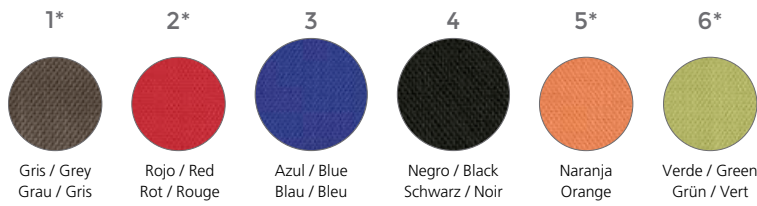

*Bajo pedido / *On request / *Auf Anforderung / *Sur demande

Medidas / Sizes (cm)

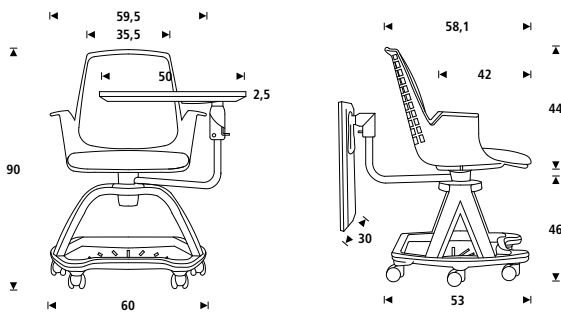

RD-928P3

Pedido mínimo consultar Rocada.
MOQ contact Rocada

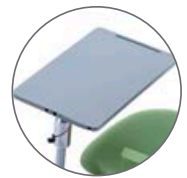

Medidas de bandeja:
Personal work surface size:
49,7x29,7cm

Ref.	cm (embalaje / packaging)	kg / m ³ (embalaje / packaging)
RD-928-1*	64x63x34	14 kg / 0,137 m ³
RD-928-2*	64x63x34	14 kg / 0,137 m ³
RD-928-3	64x63x34	14 kg / 0,137 m ³
RD-928-4	64x63x34	14 kg / 0,137 m ³
RD-928-5*	64x63x34	14 kg / 0,137 m ³
RD-928-6*	64x63x34	14 kg / 0,137 m ³
RD-928P3 (para instalaciones / for tenders)	70x60x50	14 kg / 0,210 m ³

SILLAS TRANSFORMABLES

TRANSFORMABLE CHAIRS • TRANSFORMIERBARE STÜHLE
CHAISES TRANSFORMABLES

[ESP] Silla multifuncional plegable y transformable en mesa con un solo click. La mejor opción para salas polivalentes. Realizada en polímero técnico con base metálica cromada. Se entrega montada.

[ENG] Foldable, multifunctional chair, transformable into a table with only one click. The best option for multiuse rooms. Made of technical polymer with chromed metal base. Comes assembled.

[DE] Der vielseitige Transformer - Stuhl – lässt sich im Handumdrehen zum Tisch umwandeln! Die ideale Lösung für Mehrzweckräume mit unterschiedlichen Nutzungsformen! Stabile Kunststoffschale mit verchromtem Metallgestell. Stapelbar. Auslieferung erfolgt im vormontierten Zustand.

[FR] Fauteuil multifonctions pliable et transformable en table à l'aide d'une simple pression. Le choix idéal pour les salles polyvalentes. Polymère technique sur base métallique chromée. Empilable. Livrée montée.



UNE EN 13761
UNE EN 1022





RD-992TY
Carro para sillas (máx 8)
Trolley for chair (max 8)



Rueda con freno
Castor with brake

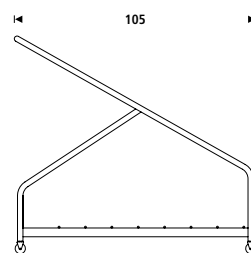
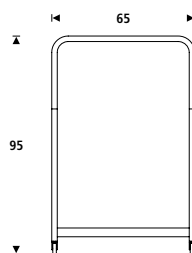

Medidas / Sizes (cm)

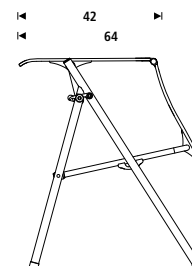
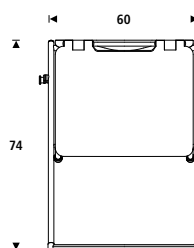
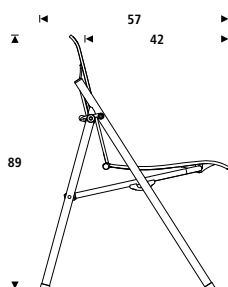
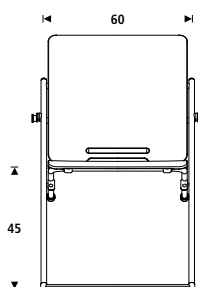

Ref.	cm (embalaje / packaging)	kg / m ³ (embalaje / packaging)
RD-992V19-4 (2u.)	105x61x30	21 kg / 0,192 m ³
RD-992TY	110x97x65	12 kg / 0,693 m ³ (Max 8 sillas / chairs)

SILLA CONFIDENTE

VISITOR'S CHAIR • BESUCHERSTUHL • CHAISE DE VISITEUR

[ESP] Silla confidente profesional tapizada en tela ignífuga, ergonómica y con estructura cromada, ideal para despachos de dirección. Incorpora brazos de serie. Fácil montaje.

[ENG] Professional office chair with flame retardant fabric, ergonomic with chromed based structure. Perfect for Director's offices. Incorporates arms. Comes mounted.

[DE] Graziler Besucher- und Konferenzstuhl mit Freischwinger-Effekt. Sitzfläche und Rückenlehne mit feuerhemmendem, chargiertem Stoffbezug in 3 attraktiven Farben. Verchromtes Stuhlgestell mit integrierten Armlehnen.

[FR] Siège visiteur tapissé de toile ignifugee, ergonomique, avec structure chromée, idéale pour les bureaux de direction. Comprend des bras de série. Livré monté.



UNE EN 13761
UNE EN 1022



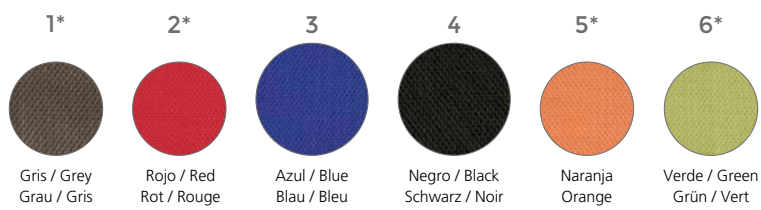

*Bajo pedido / *On request / *Auf Anforderung / *Sur demande

Medidas / Sizes (cm)

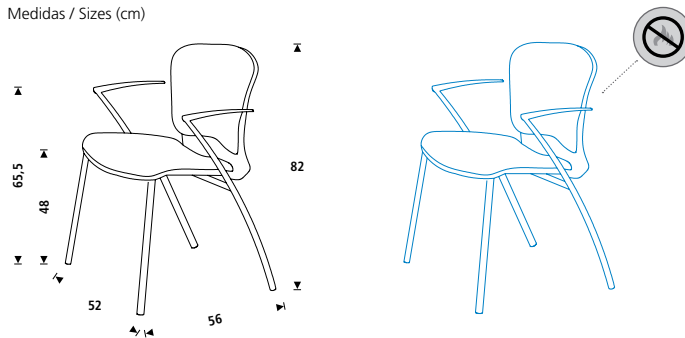

Ref.	cm (embalaje / packaging)	kg / m ³ (embalaje / packaging)
RD-966/1* (2u.)	72x59x56	18 kg / 0,238 m ³
RD-966/2* (2u.)	72x59x56	18 kg / 0,238 m ³
RD-966/3 (2u.)	72x59x56	18 kg / 0,238 m ³
RD-966/4 (2u.)	72x59x56	18 kg / 0,238 m ³
RD-966/5* (2u.)	72x59x56	18 kg / 0,238 m ³
RD-966/6* (2u.)	72x59x56	18 kg / 0,238 m ³

SILLA CONFIDENTE

VISITOR'S CHAIR • BESUCHERSTUHL • CHAISE DE VISITEUR

[ESP] Silla confidente de oficina con el asiento tapizado con tela ignífuga sobre interior de espuma inyectada y el respaldo realizado en polímero técnico inyectado. Estructura metálica reforzada pintada en epoxy color gris. Fácil montaje.

[ENG] Visitor/boardroom chair with flame proof padded fabric seat, generous size. Polymer mesh back. Metallic base reinforced and painted in grey epoxy color. Easy assembly.

[DE] Besucherstuhl im modernen Design mit Stoffbezug. Polsterung aus atmungsaktivem Formschaum, Rückenlehne aus Polymergeflecht. Lackiertes Metallgestell. Leichte Montage.

[FR] Chaise visiteur de bureau, assise en toile ignifugée sur coussin de mousse injectée et dossier en polymère technique injecté. Piètement laqué. Facile à monter.



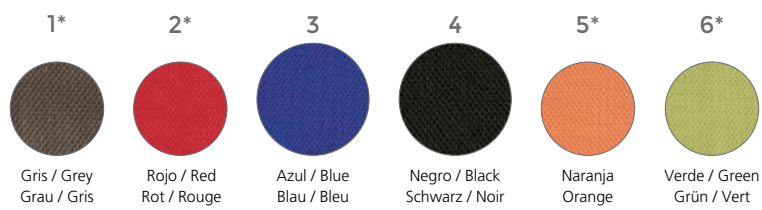

*Bajo pedido / *On request / *Auf Anforderung / *Sur demande

Medidas / Sizes (cm)

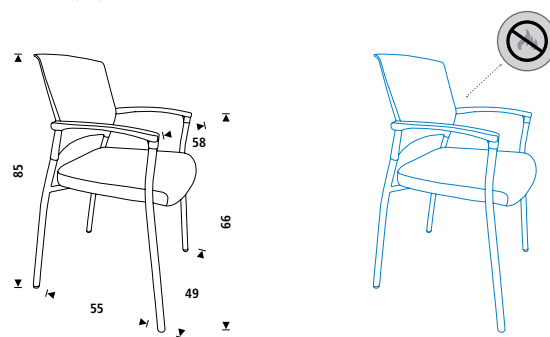

Ref.	cm (embalaje / packaging)	kg / m ³ (embalaje / packaging)
RD-906/1* (2u.)	65,5x61x55	13,50 kg / 0,219 m ³
RD-906/2* (2u.)	65,5x61x55	13,50 kg / 0,219 m ³
RD-906/3 (2u.)	65,5x61x55	13,50 kg / 0,219 m ³
RD-906/4 (2u.)	65,5x61x55	13,50 kg / 0,219 m ³
RD-906/5* (2u.)	65,5x61x55	13,50 kg / 0,219 m ³
RD-906/6* (2u.)	65,5x61x55	13,50 kg / 0,219 m ³

SILLA CONFIDENTE

VISITOR'S CHAIR • BESUCHERSTUHL • CHAISE DE VISITEUR

[ESP] Silla confidente con estructura tubular de acero cromado y carcasa monobloc de polímero técnico. Dispone de sistema de anclaje en la parte inferior de la estructura para construir y alinear filas de sillas en salas polivalentes, conferencias, pasillos, etc.

[ENG] Visitor chair with tubular structure of chrome-plated steel and monoblock body of technical polymer. It has a anchorage system in the lower part of the structure to align rows of chairs in multi-purpose rooms, conferences, etc.

[DE] Verkettbarer Konferenzstuhl mit verchromtem Stahlrohrgestell. Rückenlehne und Sitzschale aus Kunststoff...

[FR] Chaise de visiteur avec structure tubulaire en acier chromé et carcasse monobloc en polymère technique. Pourvue d'un système d'ancrage sur la partie inférieure pour effectuer et aligner des rangées de chaises en salles polyvalentes, conférence, etc, ...





Estructura con sistema de unión incluido
Structure with joint system

Medidas / Sizes (cm)

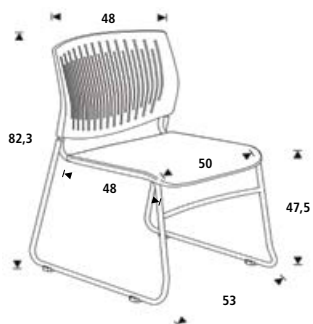

NEW



1A01606
Carro para sillas
(máx. 20 sillas)
Trolley for chairs
(20 chairs max.)

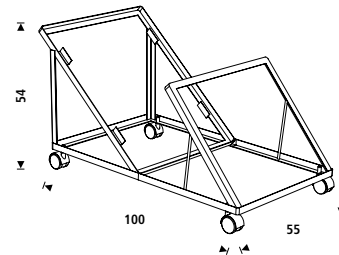

Ref.	cm (embalaje / packaging)	kg / m ³ (embalaje / packaging)
RD-968-4	83x58x52	6 kg / 0,250 m ³
1A01606	101x57,5x58	11,17 kg / 0,250 m ³ (Max 20 sillas / chairs)

SILLA CONFIDENTE

VISITOR'S CHAIR • BESUCHERSTUHL • CHAISE DE VISITEUR

[ESP] Silla confidente con base metálica reforzada pintada en epoxy color negro. Con asiento y respaldo tapizado en tela. Viene montada.

[ENG] Fabric conference chair. Seat and back upholstered. Metallic base reinforced and painted in black epoxy color. Comes assembled.

[DE] Attraktiver Stapelstuhl mit Stoffbezug und lackiertem Metallgestell.

[FR] Chaise de bureau ECO en structure tapissé. Base métallique laqué. Vienne assemblé.oues de parquet RD-917. Livrée montée.





RD-965TY

Carro para sillas (máx. 9 sillas)
Trolley for chairs (9 chairs max.)
(pag. 67)

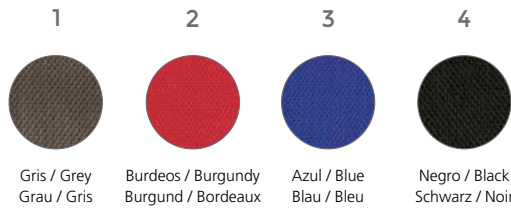

Gris / Grey
Grau / Gris

Burdeos / Burgundy
Burgund / Bordeaux

Azul / Blue
Blau / Bleu

Negro / Black
Schwarz / Noir

Medidas / Sizes (cm)

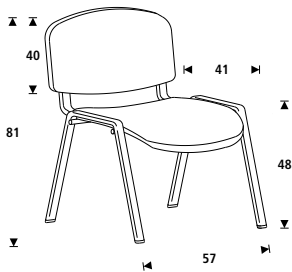

RD-977

Opcional / Optional



RD-978

Opcional / Optional



RD-979

Opcional / Optional



RD-977 (Pala derecha / Right work surface). Medidas / Sizes: 34 x 20 cm.

RD-978 (Pala izquierda / Left work surface). Medidas / Sizes: 27 x 27 cm.

Ref.	cm (embalaje / packaging)	kg / m ³ (embalaje / packaging)
RD-965/1	81x60x54	5,20 kg / 0,262 m ³
RD-965/2	81x60x54	5,20 kg / 0,262 m ³
RD-965/3	81x60x54	5,20 kg / 0,262 m ³
RD-965/4	81x60x54	5,20 kg / 0,262 m ³
RD-977 (Pala derecha / Right tray)	35x30x15	3,8 kg / 0,075 m ³
RD-978 (Pala izquierda / Left tray)	35x30x15	3,8 kg / 0,075 m ³
RD-979 (Brazos / Armrest)	35x30x15	3,8 kg / 0,075 m ³

SILLA CONFIDENTE

VISITOR'S CHAIR • BESUCHERSTUHL • CHAISE DE VISITEUR

[ESP] Silla confidente con respaldo y asiento realizado en madera. Estructura metálica reforzada pintada en epoxy color gris. Viene montada.

[ENG] Conference chair. Wood structure. Metallic base reinforced and painted in grey epoxy color. Comes assembled.

[DE] Stapelstuhl. Sitz und Rückenlehne aus Schichtholz. Lackiertes Metallgestell. Fertig montiert.

[FR] Chaise de bureau ECO en structure bois. Base métallique laqué. Livrée montée.





RD-977
Opcional / Optional

RD-978
Opcional / Optional

RD-979
Opcional / Optional



RD-977 (Pala derecha / Right work surface). Medidas / Sizes: 34 x 20 cm.
RD-978 (Pala izquierda / Left work surface). Medidas / Sizes: 27 x 27 cm.



Medidas / Sizes (cm)

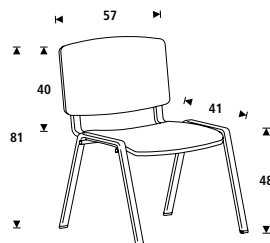

RD-965TY

Carro para sillas (máx. 9 sillas)
Trolley for chairs (9 chairs max.)
(pag. 67)



Ref.	cm (embalaje / packaging)	kg / m ³ (embalaje / packaging)
RD-974S	81x60x54	6 kg / 0,262 m ³
RD-977 (Pala derecha / Right tray)	35x30x15	3,8 kg / 0,075 m ³
RD-978 (Pala izquierda / Left tray)	35x30x15	3,8 kg / 0,075 m ³
RD-979 (Brazos / Armrest)	35x30x15	3,8 kg / 0,075 m ³

SILLA CONFIDENTE

VISITOR'S CHAIR • BESUCHERSTUHL • CHAISE DE VISITEUR

[ESP] Silla confidente con respaldo y asiento de polímero técnico y base metálica reforzada pintada en epoxy color negro. Viene montada.

[ENG] Conference chair with plastic structure. Metallic base reinforced and painted in black epoxy color. Comes assembled.

[DE] Stapelstuhl mit Kunststoff Sitz und lackiertem Metallgestell.

[FR] Chaise de bureau ECO en structure plastique. Base métallique laquée. Livrée montée.





RD-965TY

Carro para sillas (máx. 9 sillas)
Trolley for chairs (9 chairs max.)
(pag. 67)

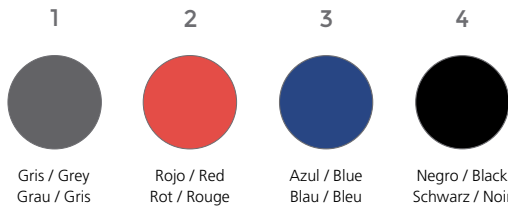

Gris / Grey
Grau / Gris

Rojo / Red
Rot / Rouge

Azul / Blue
Blau / Bleu

Negro / Black
Schwarz / Noir

Medidas / Sizes (cm)

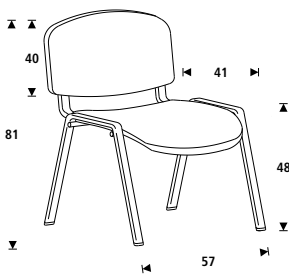

RD-977
Opcional / Optional



RD-978
Opcional / Optional



RD-979
Opcional / Optional



RD-977 (Pala derecha / Right work surface). Medidas / Sizes: 34 x 20 cm.

RD-978 (Pala izquierda / Left work surface). Medidas / Sizes: 27 x 27 cm.

Ref.	cm (embalaje / packaging)	kg / m ³ (embalaje / packaging)
● RD-975V15-1	81x60x54	5,20 kg / 0,262 m ³
● RD-975V15-2	81x60x54	5,20 kg / 0,262 m ³
● RD-975V15-3	81x60x54	5,20 kg / 0,262 m ³
● RD-975V15-4	81x60x54	5,20 kg / 0,262 m ³
RD-977 (Pala derecha / Right tray)	35x30x15	3,8 kg / 0,075 m ³
RD-978 (Pala izquierda / Left tray)	35x30x15	3,8 kg / 0,075 m ³
RD-979 (Brazos / Armrest)	35x30x15	3,8 kg / 0,075 m ³

SILLA CONFIDENTE

VISITOR'S CHAIR • BESUCHERSTUHL • CHAISE DE VISITEUR

[ESP] Carro para sillas serie RD-965, RD-974S y RD-975V15. Permite el almacenamiento y el correcto transporte de 9 sillas sin esfuerzo. Realizado en tubo de acero. Se entrega montado.

[ENG] Trolley for chairs RD-965 / RD-974S / RD-975V15 series. It allows to store and the best way to transport 9 units. Made in Epoxy painted steel tube and sheet. Allows to stack up to 9 chairs.

[DE] Stuhlwagen Serie RD-965, RD-974S und RD-975V15. Ermöglicht die Aufbewahrung und den ordnungsgemäßen Transport von 9 Stühlen ohne große Anstrengung. Aus Stahlrohr gefertigt. Wird montiert geliefert.

[FR] Chariot pour chaises série RD-965, RD-974S et RD-975V15. Destiné au stockage et au transport de 9 chaises sans effort. Fabriqué en tube d'acier. Livré monté.



NEW



Medidas / Sizes (cm)

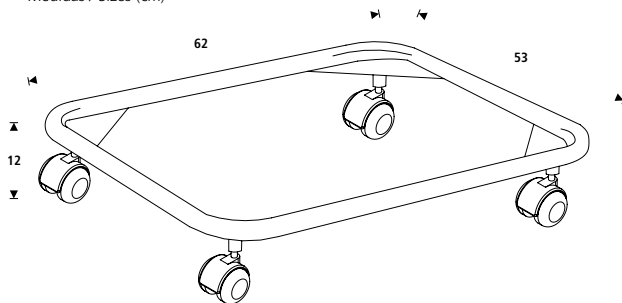

Ref.	cm (embalaje / packaging)	kg / m ³ (embalaje / packaging)
RD-965TY (máx 9 sillas / chairs)	65x55x8	6,00 kg / 0,028 m ³

SILLA CONFIDENTE

VISITOR'S CHAIR • BESUCHERSTUHL • CHAISE DE VISITEUR

[ESP] Silla de oficina plegable con asiento, respaldo y estructura metálica ideal para salas polivalentes, reuniones... Viene montada.

[ENG] Folding office chair with metal structure, ideal for multi-purpose rooms, meetings, etc. Comes assembled.

[DE] Büroklapstuhl mit Metallgestell für Mehrzweckräume, Tagungen, usw. Wird montiert geliefert.

[FR] Chaise de bureau pliante en structure métallique, idéale pour salles polyvalentes, réunions... Livrée montée.





Medidas / Sizes (cm)

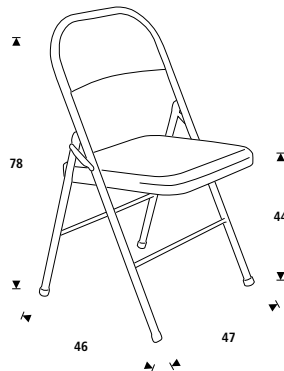

Ref.	cm (embalaje / packaging)	kg / m ³ (embalaje / packaging)
RD-921V15-4 (2 u.)	97x48x11	7,35 kg / 0,051 m ³

TABURETES

STOOLS • HOCKER • TABOURETS

[ESP] Taburete móvil con asiento y respaldo realizado en polímero técnico de alta resistencia para usos exigentes con mecanismo básico. Pistón de gas de largo recorrido. Base de polímero técnico con tacos antideslizantes. Admiten ruedas de parquet. Fácil montaje.

[ENG] Technical polymer back and seat mobile stool to hard uses with basic mechanism. Long run gas lift. Polymer technical base with stud slip. Optional castors or laminated floor castors. Easy assembly.

[DE] Sitzfläche und Rückenlehne aus widerstandsfähigen, pflegeleichten Kunststoff. Ergonomisch geformt. Stabiles Fünffußgestell mit Bodengleitern und Fußring. Permanentkontaktmechanik mit langer Gasdruckfeder. Rollen für Teppich- oder Hartböden als Zubehör erhältlich.

[FR] Tabouret mobile, assise et dossier en polymère technique haute résistance pour utilisation quotidienne avec mécanisme standard. Piston longue course. Base en polymère technique avec crampons anti-dérapants. Possibilité de roues standard ou de roues spécial parquet. Montage facile.





Regulación altura reposa pies
Footrest height adjustable

Medidas / Sizes (cm)

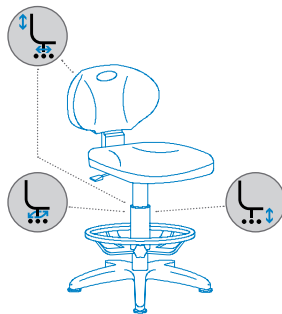
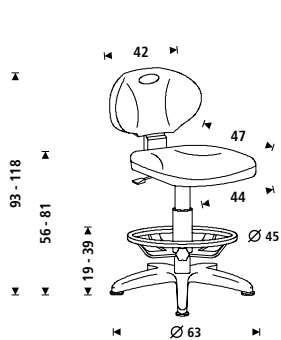

RD-917
Opcional / Optional



Ruedas parquet Ø60mm
Laminated floor castors Ø60mm
Hartbodenrollen Ø60mm
Roulettes parquet Ø60mm

Ref.	cm (embalaje / packaging)	kg / m ³ (embalaje / packaging)
RD-925N	64x63x33	12,80 kg / 0,133 m ³
RD-917	11x6,3x25	0,5 kg / 0,001 m ³

TABURETES

STOOLS • HOCKER • TABOURETS

[ESP] Taburete móvil de tela ignifuga y base metálica, con mecanismo básico. Pistón de gas de largo recorrido. Fácil montaje.

[ENG] Fire-retardant fabric mobile stool with metal base and basic mechanism. Long run gas piston. Easy assembled.

[DE] Mobiler Zeichenstuhl mit Metall-Fussgestell mit fester Fusstütze., feuerfestem Stoffbezug, langer Gasdruckfeder

[FR] Chaise mobile, tissu ignifuge, base métallique, piston pneumatique de grande amplitude. Montage facile.





Medidas / Sizes (cm)

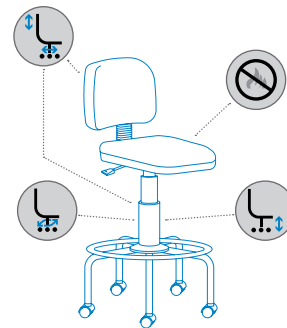
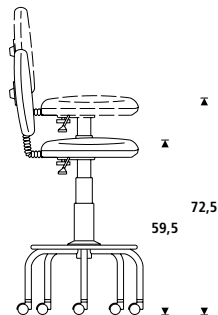
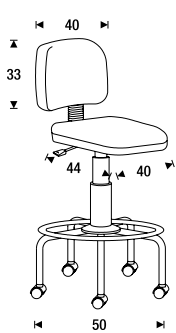

Ref.	cm (embalaje / packaging)	kg / m ³ (embalaje / packaging)
RD-980	59x58x35	9,65 kg / 0,120 m ³

TABURETES

STOOLS • HOCKER • TABOURETS

[ESP] Taburetes con estructura metálica y base de 5 pies. El asiento se regula mediante husillo giratorio. Fácil montaje.

[ENG] Stools with metallic structure and a 5-foot base. The seat is adjusted with a rotating screw. Easy assembled.

[DE] Hocker mit Metallstruktur und 5-füssigem Unterteil. Sitzhöhenverstellung mittels Spindel.

[FR] Tabourets en structure métal, avec base à 5 pieds. La hauteur se règle à l'aide de la tige giratoire.



RD-900/2



Max
125 kg



RD-900



RD-900/1

RD-900



Tapizado
Upholstered
Gepolstert
Tapissé

RD-900/1



Plástico
Plastic
Plastik
Plastique

RD-900/2



Madera
Wood
Holz
Bois

RD-916



Juego de 5 ruedas.
Kit of 5 castors.
Satz mit 5 Rollen.
Jeu de 5 roulettes.

Medidas / Sizes (cm)

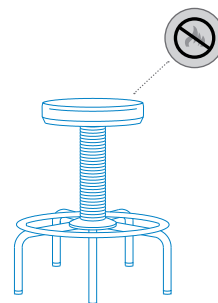
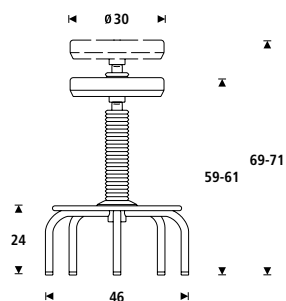

Ref.	cm (embalaje / packaging)	kg / m ³ (embalaje / packaging)
RD-900	49x48x33	6 kg / 0,078 m ³
RD-900/1	49x48x33	5,8 kg / 0,078 m ³
RD-900/2	49x48x33	4,8 kg / 0,078 m ³
RD-916	25x11x5,3	0,5 kg / 0,001 m ³

SILLAS GAMING

GAMING CHAIRS • GAMING STÜHLE • SIÈGES GAMING

[ESP] Silla GAMING PROFESIONAL de gran diseño deportivo, confort y versatilidad pensada para disfrutar en tus momentos de ocio o de trabajo diario. Tapizada en simil piel. Robusta base de polímero técnico (nylon) con ruedas de gran diseño (60mm de diámetro). Mecanismo basculante de grandes prestaciones para uso diario. Respaldo y asientos de espuma inyectada con formas ergonómicas para conseguir mantener posturas corporales correctas en todo momento. Cojines lumbar y cervical regulables que aumentan el confort. Respaldo reclinable 155° que permite fijar el ángulo de inclinación deseado. Reposacabezas integrado. Brazos regulables de serie

[ENG] GAMING PROFESSIONAL chair with great sporty design, comfort and versatility designed to enjoy your leisure time or daily work. Upholstered in imitation leather. Robust technical polymer base (nylon) with large design wheels (60mm diameter). Rocker mechanism for daily use. Backrest and injected foam seats with ergonomic shapes to achieve correct body postures at all times. Adjustable cervical and lumbar cushions that increase comfort. 155° reclining backrest that allows you to set the desired angle of inclination. Integrated headrest. Adjustable arms.

[DE] Der Stuhl GAMING PROFESIONAL, mit ausgeprägt sportlichem Design, hohem Komfort und vielseitigen Einsatzmöglichkeiten, ist sowohl für Freizeit als auch tägliche Arbeit gedacht. Bezug aus Lederimitat. Robuste Basis aus technischem Kunststoff (Nylon) mit großen Rollen (60 mm Durchmesser). Wippmechanik mit großem Leistungsumfang für den täglichen Einsatz. Rückenlehne und Sitzflächen aus gespritztem Schaum sind ergonomisch geformt, um jederzeit eine ordnungsgemäße Körperhaltung zu ermöglichen. Verstellbare Lenden- und Nackenstützen für erhöhten Komfort. 155 Grad schwenkbare Rückenlehne mit Arretierung des gewünschten Neigungswinkels. Einschließlich Kopfstütze. Verstellbare Armlehnen serienmäßig.

[FR] Chaise GAMING PROFESIONAL au design sport, associant confort et polyvalence, conçue pour vos moments de loisirs et de travail quotidiens. Tapissée en simili cuir. Robuste base en polymère technique (nylon) avec des roues de grande qualité (600 mm de diamètre). Mécanisme basculant aux grandes prestations pensé pour une utilisation quotidienne. Dossier et assise en mousse injectée aux formes ergonomiques afin que la position du corps soit correcte à tout moment. Coussin lombaire réglable et coussin cervical pour plus de confort. Dossier inclinable à 155° permettant de bloquer l'inclinaison souhaitée. Appuie-tête intégré. Accoudoirs réglables de série.





2
Rojo / Red
Rot / Rouge

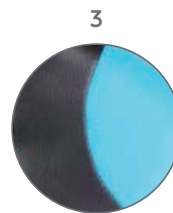

3
Azul / Blue
Blau / Bleu

Medidas / Sizes (cm)

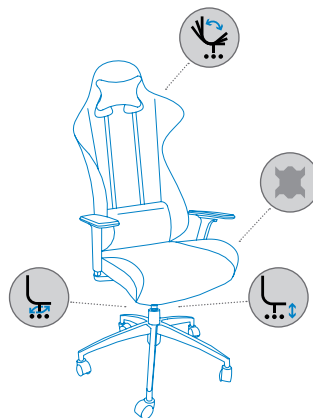
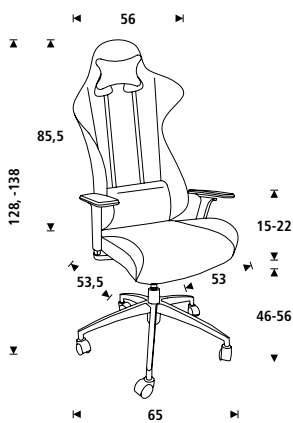

Ref.	cm (embalaje / packaging)	kg / m ³ (embalaje / packaging)
● RD-914-2	86x66x32,5	22,80 kg / 0,184 m ³
● RD-914-3	86x66x32,5	22,80 kg / 0,184 m ³

SILLAS GAMING

GAMING CHAIRS • GAMING STÜHLE • SIÈGES GAMING

[ESP] Silla GAMING STUDENT de diseño deportivo, fabricada con una cómoda espuma pensada para disfrutar en tus momentos de ocio o de trabajo. Tapizada en simil piel. Robusta base de polímero técnico (nylon) con ruedas de 50mm de diámetro. Mecanismo basculante de grandes prestaciones para uso diario. Respaldo y asientos de espuma inyectada con formas ergonómicas para conseguir mantener posturas corporales correctas en todo momento. Reposacabezas integrado. Brazos de serie.

[ENG] STUDENT GAMING chair with a sporty design, made with a comfortable foam designed to enjoy your leisure or working time. Upholstered in imitation leather. Robust technical polymer base (nylon) with wheels (50mm diameter). Great benefit like the rocking mechanism for daily use. Backrest and injected foam seats with ergonomic shapes to achieve correct body postures at all times. Integrated headrest. Arms included.

[DE] Der Stuhl GAMING STUDENT besitzt ein sportliches Design, ist aus bequemem Schaumstoff gefertigt und sowohl für Freizeit als auch Arbeit gedacht. Bezug aus Lederimitat. Robuste Basis aus technischem Kunststoff (Nylon) mit großen Rollen (50 mm Durchmesser). Wippmechanik mit großem Leistungsumfang für den täglichen Einsatz. Rückenlehne und Sitzflächen aus gespritztem Schaum sind ergonomisch geformt, um jederzeit eine ordnungsgemäße Körperhaltung zu ermöglichen. Einschließlich Kopfstütze. Armlehnen serienmäßig.

[FR] Chaise GAMING STUDENT au design sport, fabriquée en mousse agréable pensée pour profiter de vos moments de loisirs et de travail. Tapissée en simili cuir. Base en polymère technique (nylon) robuste avec des roues de grande qualité (50 mm de diamètre). Mécanisme basculant aux grandes prestations pensé pour une utilisation quotidienne. Dossier et assise en mousse injectée aux formes ergonomiques afin que la position du corps soit correcte à tout moment. Appuie-tête intégré. Accoudoirs de série.





NEW



2



Rojo / Red
Rot / Rouge

3

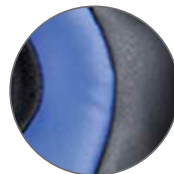

Azul / Blue
Blau / Bleu

Medidas / Sizes (cm)

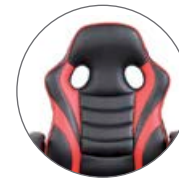
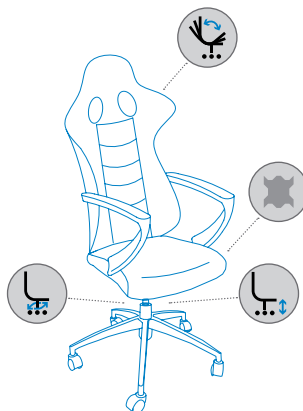
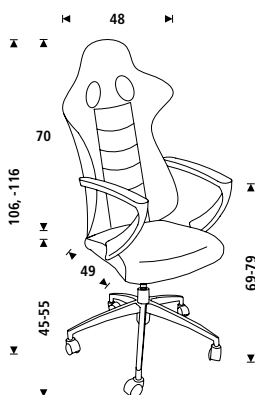

PU transpirable
Breathable PU



Brazos fijos
Fixed armrest

Ref.	cm (embalaje / packaging)	kg / m ³ (embalaje / packaging)
● RD-913-2	77x59x28	15,70 kg / 0,127 m ³
● RD-913-3	77x59x28	15,70 kg / 0,127 m ³

SILLAS GAMING

GAMING CHAIRS • GAMING STÜHLE • SIÈGES GAMING

[ESP] Silla GAMING BASIC de diseño deportivo para disfrutar en tus momentos de ocio o de trabajo. Tapizada en simil piel. Robusta base de polímero técnico (nylon) con ruedas de 50mm de diámetro. Mecanismo básico. Respaldo y asientos de espuma inyectada. Reposacabezas integrado. Brazos de serie.

[ENG] GAMING BASIC chair with sporty design to enjoy during your leisure or work moments. Upholstered in imitation leather. Robust technical polymer base (nylon) with wheels 50mm diameter. Basic mechanism Backrest and seats with injected foam. Integrated headrest. Arms included.

[DE] Der Stuhl GAMING BASIC besitzt ein sportliches Design, damit Sie sowohl Freizeit als auch Arbeit genießen können. Bezug aus Lederimitat. Robuste Basis aus technischem Kunststoff (Nylon) mit großen Rollen (50 mm Durchmesser). Basic-Mechanismus. Rückenlehne und Sitzflächen aus gespritztem Schaum. Einschließlich Kopfstütze. Armlehnen serienmäßig

[FR] Chaise GAMING BASIC au design sport pour profiter lors de vos moments de loisirs et de travail. Tapissée en simili cuir. Base en polymère technique (nylon) robuste avec des roues de grande qualité (50 mm de diamètre). Mécanisme basique. Dossier et assise en mousse injectée. Appuie-tête intégré. Accoudoirs de série.





NEW



2



Rojo / Red
Rot / Rouge

3



Azul / Blue
Blau / Bleu

Medidas / Sizes (cm)

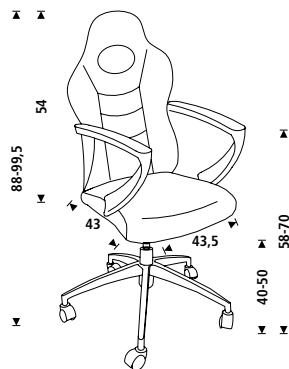

PU transpirable
Breathable PU



Brazos fijos
Fixed armrest

Ref.	cm (embalaje / packaging)	kg / m ³ (embalaje / packaging)
● RD-912-2	58,5x52,5x22,5	11,20 kg / 0,069 m ³
● RD-912-3	58,5x52,5x22,5	11,20 kg / 0,069 m ³

ACABADOS TAPIZADOS

FINISHES • OBERFLÄCHEN • FINITIONS

RD-966 • RD-944V15 • RD-939V19 • RD-937V19
RD-928 • RD-908W • RD-908 • RD-907 • RD-906

1. Gris / Grey



2. Rojo / Red



3. Azul / Blue

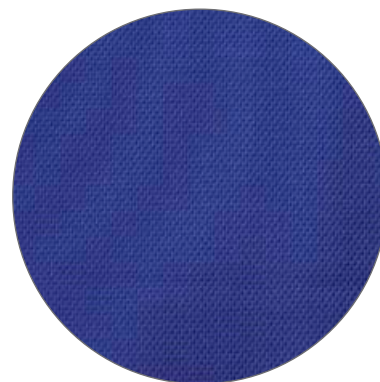

4. Negro / Black



5. Naranja / Orange



6. Verde / Green

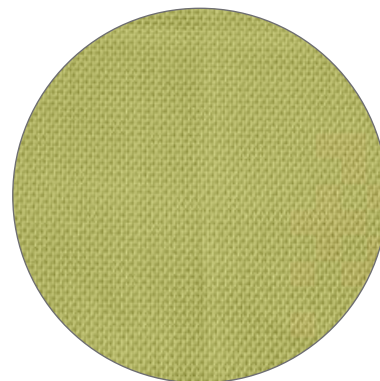

 Todos los modelos / All models

RD-998V15 • RD-990 • RD-988 • RD-987
RD-986 • RD-985 • RD-973 • RD-972 • RD-971 • RD-966

Símil Piel / Imitation leather



RD-965 · RD-930 + 956 · RD-930 · RD-911+958

1. Gris / Grey



2. Burdeos / Burgundy



3. Azul / Blue

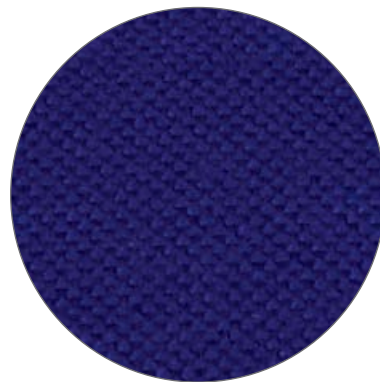

4. Negro / Black

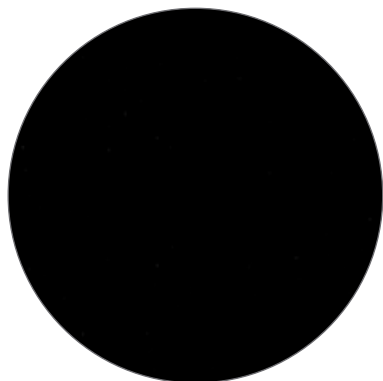

ACABADOS TAPIZADOS BE SOFT

SOFT SEATING FINISHES • SOFT SEATING OBERFLÄCHEN • FINITIONS SOFT SEATING

1804-4-1 • 1805-4-1 • 1806-4-1

4. Negro / Black



1. Gris / Grey



ACABADOS BAJO PEDIDO PANEL TRASERO · BACK PANEL FINISHES ON REQUEST

2. Rojo / Red



3. Azul / Blue

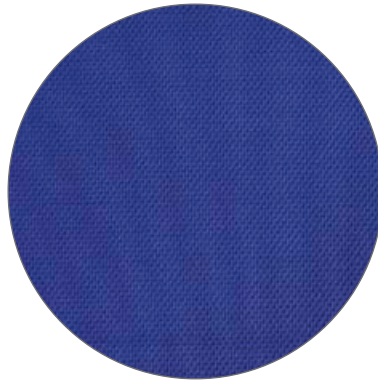

4. Negro / Black



5. Naranja / Orange

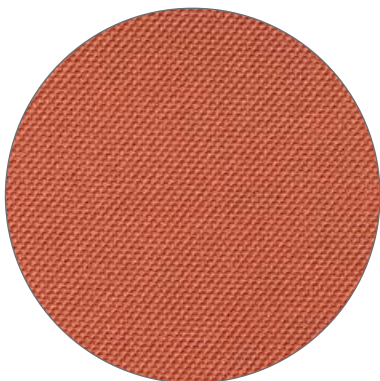

6. Verde / Green

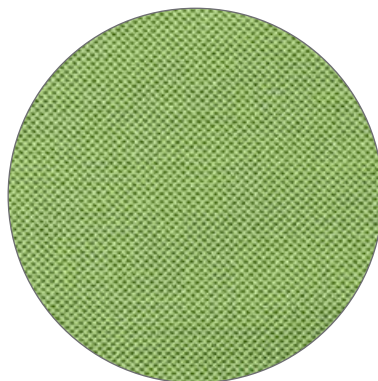



Sistema basculante

El conjunto de asiento y respaldo formando una sola unidad permite un suave balanceo hacia atrás. Se puede regular la tensión del balanceo en función del peso de la persona con el pomo de la parte inferior del asiento. Una ligera presión en la palanca de gas permite activar o desactivar este sistema basculante.



Sistema Sincro-basculante

Este mecanismo permite que asiento y respaldo se adapten sincronizadamente a los movimientos realizados por la persona sentada. Cuando el respaldo se inclina para atrás o adelante, se ajusta también de forma automática el asiento, consiguiendo una posición de trabajo perfecta en cada momento. Esta posición se puede fijar en la postura idónea en cualquier posición de su recorrido. Este sistema permite también un suave balanceo, regulable en tensión en función del peso de cada persona.

Swivelling system

The seat and the backrest are formed of one unit which permits a smooth backward movement. The regulation of the tension and balance can be adjusted according to the weight of the user with the lever under the seat. A lightweight pressure with the gas handle activates or deactivates this rocking system.

Synchro-swivelling system

This mechanism allows the seat and backrest to adjust in synchronisation with the seated person's movements. When the backrest is tilted backwards or forwards, the seat also adjusts automatically to achieve a perfect working position at all times. This position can be set at any point along its travel to give the best postural support. The system also permits gentle rocking, with resistance adjustable to take account of the user's weight.

Wippmechanik

Die Einheit von Sitz und Rückenlehne ermöglicht ein sanftes Zurückschwingen. Die Sitzneigung kann auf das jeweilige Körpergewicht eingestellt werden.

Synchronmechanik

Bei der Synchronmechanik werden Sitzfläche und Rückenlehne in einem feststehenden Winkel zueinander bewegt, der Körper wird optimal unterstützt. Eine Feststellung ist in jeder Sitzposition möglich.

Système basculant

Le siège et le dos formant une seule unité, permet un léger balancement en arrière. On peut régler la tension du balancement en fonction du poids de la personne en actionnant le bouton situé en dessous de l'assise. Une légère pression sur la poignée de gaz permet d'activer ou désactiver ce système basculant.

Système Synchro-basculant

Ce système permet d'adapter de façon synchronisée le siège et le dos en fonction des mouvements de la personne qui est assise. Lorsque le dossier est inclinée en arrière ou en avant, l'assise s'ajuste aussi automatiquement, on parvient ainsi une position de travail parfaite à tout moment. Cette position peut se caler sur la posture idéale pour toute position de son parcours. Ce système permet également d'avoir un léger balancement, dont on peut régler la tension en fonction du poids de chaque personne.



Sistema de contacto permanente.

System of permanent contact.

Permanent-Kontaktsystem. Die Rückenlehne folgt permanent dem Körper und unterstützt die Bewegung von einer zurückgelehnten in eine aufrechte Haltung.

Système de contact permanent.



Altura regulable mediante pistón de gas, libre de mantenimiento y con sistema de suspensión.

Adjustable height through gas piston, maintenance free and through suspension system.

Höhenverstellbar mittels Gasdruckfeder, wartungsfrei.

Hauteur réglable grâce au piston à gaz, sans entretien et avec système de suspension.



Asiento giratorio 360°.

360° Rotation seat.

360° drehbar.

Siège pivotant 360°.



Respaldo regulable en altura y profundidad respecto al asiento.

Backrest adjustable in height and depth.

Rückenlehne höhen- und tiefenverstellbar zur Sitzposition.

Dos réglable en hauteur et en profondeur par rapport au siège.



Tela ignífuga 100% Modacrylic flame retardant class 1 (I) BS 5852: 1990 section 4 (cigarette and match test).

100% Modacrylic flame retardant class 1 (I) BS 5852: 1990 section 4 (cigarette and match test).

Feuerfester Stoffbezug 100% Modacrylic flame retardant class 1 (I) BS 5852: 1990 Absatz 4 (Zigaretten- und Streichholztest).

Tissu anti-feu, 100% Modacrylic retardataire de flammes, classe 1 (1) BD 5852 : 1990 section 4 (test de la cigarette et de l'allumette).



Simil piel.

Imitation leather.

Leder imitat.

Simil cuir.

ÍNDICE • INDEX



pag 6



pag 10 · 1806



pag 12 · 1805



pag 14 · 1804



pag 16 · 1828



pag 18 · RD-972



pag 20 · RD-998v15



pag 22 · RD-986



pag 24 · RD-988



pag 26 · RD-990



pag 28 · RD-966



pag 30 · RD-985



pag 32 · RD-987



pag 34 · RD-944v15



pag 36 · RD-937V19



pag 38 · RD-939v19

ÍNDICE • INDEX



pag 40 · RD-908W



pag 42 · RD-908



pag 44 · RD-907



pag 46 · RD-911+958



pag 48 · RD-930



pag 48 · RD-930 + 956



pag 50 · RD-928



pag 52 · RD-992V19



pag 54 · RD-966/



pag 56 · RD-906



pag 58 · RD-968



pag 60 · RD-965



pag 62 · RD-974S



pag 64 · RD-975V15



pag 66 · RD-965TY



pag 68 · RD-921v15

ÍNDICE • INDEX



pag 70 · RD-925N



pag 72 · RD-980



pag 74 · RD-900



pag 76 · RD-914



pag 78 · RD-913



pag 80 · RD-912

PEDIDOS

NOVEDAD WEB!

Los pedidos cursados vía web tendrán un 2% de descuento hasta fin de promoción.

Si los pedidos no se tramitan a través de la web deben de efectuarse siempre por escrito.

LISTA DE PRECIOS

Precios sin IVA.

Válidos a partir del 1 de febrero de 2019.

PAGOS

El incumplimiento del vencimiento del pago puede provocar la retención de nuevos pedidos hasta la cancelación del impago y la tramitación legal automática a través de nuestras empresas de cobro.

Anticipado 2%

GARANTÍA

2-5 años para todos los productos Rocada en condiciones de uso normales.

Rocada se compromete a entregar un producto de calidad conforme con las especificaciones requeridas.

PLAZOS DE ENTREGA

Máximo 7 días laborables para pedidos diarios.

TRANSPORTE

Portes para Península:

Pedido neto hasta 50 €: cargo de 10 € en concepto de portes.

A partir de 50 € hasta 150 €: 5 € en concepto de portes.

A partir de 150 €: portes pagados.

Portes para Canarias, Ceuta y Melilla: 800 €. El servicio de entrega de la mercancía solo se realizará hasta la puerta de la calle. Si es necesario entregar el material dentro de su destinación, la entrega tendrá un coste extra de +8% sobre PVP.

INCIDENCIAS Y DEVOLUCIONES

Avisar dentro de las 24 horas de la recepción de la mercancía para incidencias con el transporte. No se aceptarán incidencias pasadas las 24h desde la recepción. Y nunca se aceptaran devoluciones, sin previa confirmación desde Rocada.

JURISDICCIÓN

Para cuestión que pueda derivarse de la interpretación o aplicación de estas normas el cliente y Rocada se someten expresamente a la jurisdicción y fuero de los Juzgados y Tribunales de la ciudad de Barcelona, con renuncia a cualquier otro si lo hubiere.

ORDERS

All orders shall be received in writing.

PAYMENTS

All payments should be received on or before the due date indicated on the invoice. All customers shall be covered by CESCE insurance company. Rocada is forced to communicate any delay or nonpayment. Rocada is keen to offer an extra discount of -2% for in advance payments (before loading).

GUARANTEE

All Rocada products have between 2 and 5 years guarantee.

DELIVERY LEADTIME

Between 10-15 working days for stock orders. We shall inform the approximate delivery time once the order has been placed.

Each delivery shall be deemed a separate transaction and the failure of any one delivery shall not affect the due performance of the order. Any request to vary the quantity or delivery date of an order must be notified in writing. Ex-works prices.

CLAIMS - RETURN

All claims for damage to goods or partial loss of goods in transit must be submitted to, and received by us within 2 days of delivery.

No goods can be returned without prior notification and an official pick up note produced by us.

JURISDICTION

Spanish law only shall apply to this contract and all disputes shall be dealt with by the Spanish courts alone.

MODIFICACIONES / MODIFICATIONS

[ESP] Esta tarifa anula las anteriores. Nos reservamos el derecho de modificar sin previo aviso características, formas y medidas de nuestros productos. Tarifa válida excepto error tipográfico.

[ENG] This pricelist annuls all the previous ones. We reserve the right to change product specifications, sizes or colors without prior notice. Errors, omissions excluded.



Rocada Spain
rocada@rocada.com
www.rocada.com

Rocada Deutschland GmbH
info@rocada.de
www.rocada.de

Distribuido por / Distributed by: